

# Automation1 XL4s High-Performance Voice-Coil Drive

## HARDWARE MANUAL

Revision 2.00

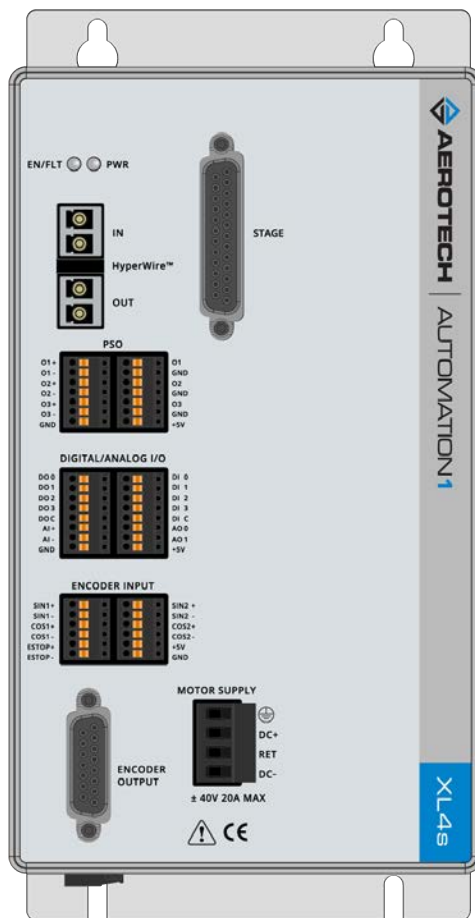

## GLOBAL TECHNICAL SUPPORT

Go to the [Global Technical Support Portal](#) for information and support about your Aerotech, Inc. products. The website supplies software, product manuals, Help files, training schedules, and PC-to-PC remote technical support. If necessary, you can complete Product Return (RMA) forms and get information about repairs and spare or replacement parts. To get help immediately, contact a service office or your sales representative. Include your customer order number in your email or have it available before you call.

This manual contains proprietary information and may not be reproduced, disclosed, or used in whole or in part without the express written permission of Aerotech, Inc. Product names mentioned herein are used for identification purposes only and may be trademarks of their respective companies.

Copyright © 2018-2020, Aerotech, Inc., All rights reserved.



## Table of Contents

<b>Automation1 XL4s High-Performance Voice-Coil Drive</b> .....	<b>1</b>
Table of Contents .....	3
List of Figures .....	4
List of Tables .....	5
EU Declaration of Conformity .....	7
Agency Approvals .....	9
Safety Procedures and Warnings .....	11
Quick Installation Guide .....	13
<b>Chapter 1: Introduction</b> .....	<b>15</b>
1.1. Electrical Specifications .....	17
1.2. Mechanical Specifications .....	18
1.2.1. Mounting and Cooling .....	18
1.2.2. Dimensions .....	19
1.3. Environmental Specifications .....	20
1.4. Drive and Software Compatibility .....	21
<b>Chapter 2: Installation and Configuration</b> .....	<b>23</b>
2.1. Input Power Connections .....	24
2.1.1. Control Supply Connector .....	24
2.1.2. Motor Supply Connector .....	25
2.1.3. External Power Supply Options .....	26
2.1.4. Minimizing Noise for EMC/CE Compliance .....	28
2.2. HyperWire Interface .....	29
2.3. Position Synchronized Output Connector .....	30
2.4. Encoder Output Connector .....	31
2.5. Stage Motor and Feedback Connector .....	33
2.5.1. Analog Encoder Inputs .....	34
2.6. Digital and Analog I/O Connectors .....	35
2.6.1. Digital Outputs .....	36
2.6.2. Digital Inputs .....	38
2.6.3. Analog Outputs .....	39
2.6.4. Analog Inputs (Differential) .....	40
2.7. Encoder Input Connectors .....	41
2.7.1. Emergency Stop Sense Input .....	43
2.8. Laser Output Polarity Switch .....	44
2.9. Sync Port .....	45
2.10. PC Configuration and Operation Information .....	46
<b>Chapter 3: Maintenance</b> .....	<b>47</b>
3.1. Preventative Maintenance .....	48
3.2. Board Assembly .....	49
<b>Appendix A: Warranty and Field Service</b> .....	<b>51</b>
<b>Appendix B: Revision History</b> .....	<b>53</b>
<b>Index</b> .....	<b>55</b>

## List of Figures

Figure 1-1: XL4s High Performance Linear Amplifier .....	15
Figure 1-2: Functional Diagram .....	16
Figure 1-3: Dimensions .....	19
Figure 2-1: Control Supply Connections .....	24
Figure 2-2: Motor Supply Connections .....	25
Figure 2-3: Control and Motor Power Wiring using a TM3 Transformer .....	27
Figure 2-4: Third-Party Power Supply Connection .....	27
Figure 2-5: Encoder Outputs Schematic .....	31
Figure 2-6: PSO External Sync Input Schematic .....	32
Figure 2-7: Digital Outputs Connected in Current Sourcing Mode .....	37
Figure 2-8: Digital Outputs Connected in Current Sinking Mode .....	37
Figure 2-9: Digital Inputs Connected to Current Sinking Devices .....	38
Figure 2-10: Digital Inputs Connected to Current Sourcing Devices .....	38
Figure 2-11: Analog Outputs Schematic .....	39
Figure 2-12: Analog Inputs Schematic .....	40
Figure 2-13: Encoder Input Connector Encoder Connections .....	42
Figure 2-14: ESTOP Sense Input Schematic .....	43
Figure 2-15: Laser Output Polarity Switch Location .....	44
Figure 3-1: Control Board Assembly .....	49
Figure 3-2: Power Board Assembly .....	50

## List of Tables

Table 1-1: Feature Summary .....	15
Table 1-2: Electrical Specifications .....	17
Table 1-3: Mounting Specifications .....	18
Table 1-4: Environmental Specifications .....	20
Table 1-5: Drive and Software Compatibility .....	21
Table 2-1: Control Supply Connector Wiring Specifications .....	24
Table 2-2: Mating Connector Part Numbers for the Control Supply Connector .....	24
Table 2-3: Motor Supply Wiring Specifications .....	25
Table 2-4: Mating Connector Part Numbers for the Motor Supply Connector .....	25
Table 2-5: HyperWire Card Part Number .....	29
Table 2-6: HyperWire Cable Part Numbers .....	29
Table 2-7: PSO Connector A Pinout .....	30
Table 2-8: PSO Connector B Pinout .....	30
Table 2-9: Mating Connector Part Numbers for the PSO Connectors .....	30
Table 2-10: PSO Specifications .....	30
Table 2-11: Encoder Output Connector Pinout .....	31
Table 2-12: Mating Connector Part Numbers for the Encoder Output Connector .....	31
Table 2-13: PSO External Sync Specifications .....	32
Table 2-14: Stage Motor and Feedback Connector Pinout .....	33
Table 2-15: Mating Connector Part Numbers for the Stage Motor and Feedback Connector .....	33
Table 2-16: Analog Encoder Input Specifications .....	34
Table 2-17: Digital and Analog I/O Connector A Pinout .....	35
Table 2-18: Digital and Analog I/O Connector B Pinout .....	35
Table 2-19: Mating Connector Part Numbers for the Digital / Analog I/O Connectors .....	35
Table 2-20: Digital Output Specifications .....	36
Table 2-21: Digital Output Pins on the Digital/Analog I/O A Connector .....	36
Table 2-22: Digital Input Specifications .....	38
Table 2-23: Digital Input Pins on the Digital/Analog I/O B Connector .....	38
Table 2-24: Analog Output Specifications .....	39
Table 2-25: Analog Output Pins on the Digital / Analog I/O B Connector .....	39
Table 2-26: Analog Input Specifications .....	40
Table 2-27: Analog Input Pins on the Digital / Analog I/O B Connector .....	40
Table 2-28: Encoder Input Connector Specifications .....	41
Table 2-29: Encoder Input Connector A Pinout .....	41
Table 2-30: Encoder Input Connector B Pinout .....	41
Table 2-31: Mating Connector Part Numbers for the Encoder Input Connector .....	41
Table 2-32: ESTOP Pins on the Encoder Input Connector .....	43
Table 2-33: Electrical Noise Suppression Devices .....	43
Table 2-34: Sync-Related Functions .....	45
Table 2-35: Sync Port Cables .....	45
Table 3-1: LED Description .....	47
Table 3-2: Troubleshooting .....	47
Table 3-3: Preventative Maintenance .....	48
Table 3-4: Control Board Fuse Specifications .....	49
Table 3-5: Power Board Fuse Specifications .....	50

*This page intentionally left blank.*

## EU Declaration of Conformity

**Manufacturer** Aerotech, Inc.  
**Address** 101 Zeta Drive  
 Pittsburgh, PA 15238-2811  
 USA  
**Product** XL4s  
**Model/Types** All

This is to certify that the aforementioned product is in accordance with the applicable requirements of the following Directive(s):

2014/35/EU  
 EU 2015/863

Low Voltage Directive  
 Directive, Restricted Substances (RoHS3)

*and has been designed to be in conformity with the applicable requirements of the following Standard(s) when installed and used in accordance with the manufacturer's supplied installation instructions.*

EN 61010-1:2010

Safety Requirements for Electrical Equipment

**Authorized Representative:** Simon Smith, European Director  
**Address:** Aerotech Ltd  
 The Old Brick Kiln, Ramsdell, Tadley  
 Hampshire RG26 5PR  
 UK

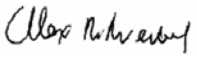
**Name**  / Alex Weibel  
**Position** Engineer Verifying Compliance  
**Location** Pittsburgh, PA  
**Date** 10/15/2020



*This page intentionally left blank.*



## Agency Approvals

Aerotech tested its XL4s drives and found that they obey the standards that follow:

<b>Approval:</b>	CUS NRTL
<b>Approving Agency:</b>	TUV SUD America Inc.
<b>Certificate #:</b>	U8 16 04 68995 018
<b>Standards:</b>	CAN/CSA-C22.2 No. 61010-1:2012; EN 61010-1:2010; UL 61010-1:2012

Visit <https://www.tuev-sued.de/product-testing/certificates> to view Aerotech's TÜV SÜD certificates. Type the certificate number listed above in the search bar or type "Aerotech" for a list of all Aerotech certificates.

*This page intentionally left blank.*

## Safety Procedures and Warnings



**IMPORTANT:** This manual tells you how to carefully and correctly use and operate the XL4s.

- Read all parts of this manual before you install or operate the XL4s or before you do maintenance to your system.
- To prevent injury to you and damage to the equipment, obey the precautions in this manual.
- All specifications and illustrations are for reference only and were complete and accurate as of the release of this manual. To find the newest information about this product, refer to [www.aerotech.com](http://www.aerotech.com).

If you do not understand the information in this manual, contact Aerotech Global Technical Support.



**WARNING:** This product has been designed for light industrial manufacturing or laboratory environments. The protection provided by the equipment could be impaired if the product is used in a manner not specified by the manufacturer.



**DANGER:** The voltage from this product can kill you. To decrease the risk of electrical shock, injury, and death, you must obey the precautions that follow.

1. Before you do maintenance to the equipment, disconnect the electrical power.
2. Wait at least ten (10) minutes after removing the power supply before doing maintenance or an inspection. Otherwise, there is the danger of electric shock.
3. Before you connect wires to this product, disconnect the electrical power.
4. To decrease the risk of electrical shock and injury, you must supply operators with the necessary precautions and protection from live electrical circuits.
5. While the drive is connected to a power source, do not connect or disconnect electrical components and cables.
6. Make sure that all components are grounded correctly and that they obey the local electrical safety requirements.
7. Make sure that you install the necessary precautions to supply safety and protection to the operator.
8. Moving parts can cause crushing or shearing injuries. You must limit access to all motor and stage parts while your system is connected to a power source.



**WARNING:** To prevent damage to the equipment and decrease the risk of electrical shock, injury, and death, you must obey the precautions that follow.

1. Make sure that all system cables are correctly attached and positioned.
2. Use this product only in environments and operating conditions that are approved in this manual.
3. Only operators who have received training can operate this equipment. All servicing and maintenance must be done only by approved personnel.

*This page intentionally left blank.*

### Quick Installation Guide

This image shows the order in which to make connections and settings that are typical to the XL4s. If a custom interconnect drawing was supplied with your system, that drawing is on your Storage Device and shows as a line item on your Sales Order in the Integration section.

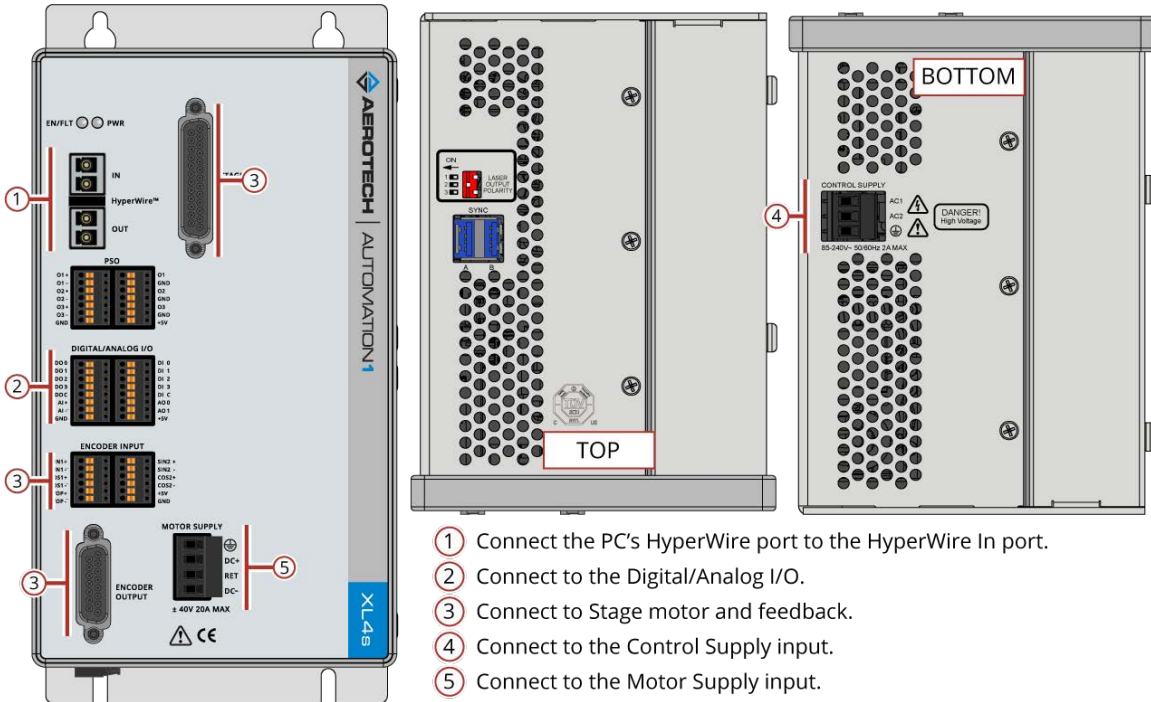

<b>HyperWire</b>	<a href="#">Section 2.2. HyperWire Interface</a>
<b>Digital / Analog I/O</b>	<a href="#">Section 2.6. Digital and Analog I/O Connectors</a>
<b>Motor and Feedback Connections</b>	<a href="#">Section 2.5. Stage Motor and Feedback Connector</a>
<b>Control Supply</b>	<a href="#">Section 2.1.1. Control Supply Connector</a>
<b>Motor Supply</b>	<a href="#">Section 2.1.2. Motor Supply Connector</a>

Figure 1: Quick Start Connections

*This page intentionally left blank.*

# Chapter 1: Introduction

The XL4s is a high-performance linear amplifier designed to eliminate the non-linearities common with PWM amplifiers. The drive provides deterministic behavior, auto-identification, and easy software setup.

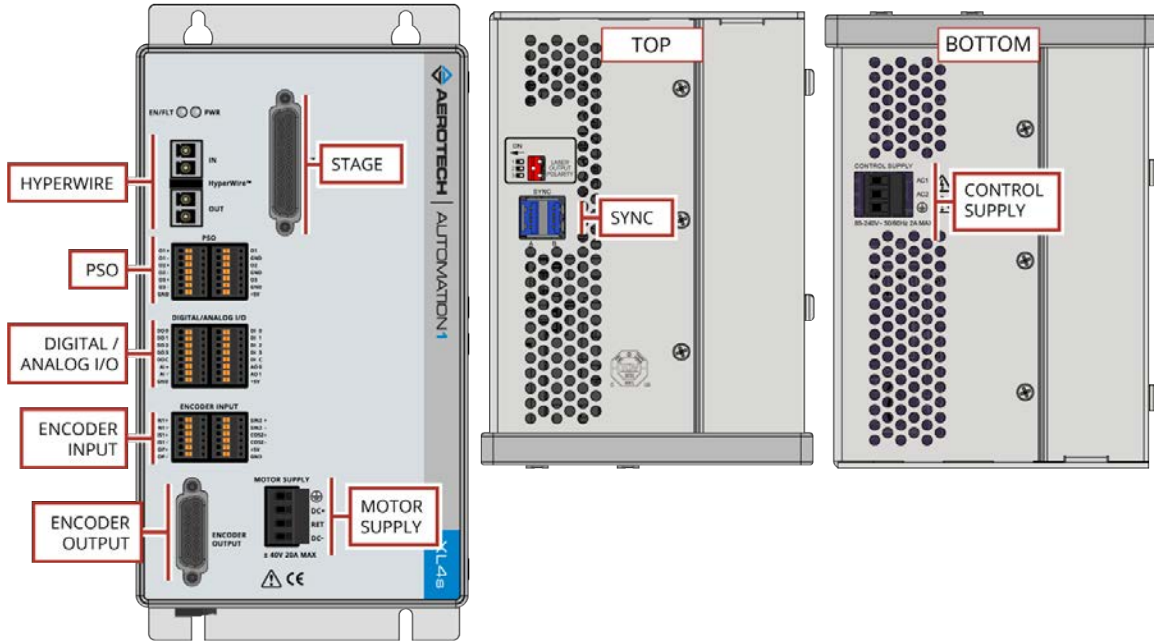

Figure 1-1: XL4s High Performance Linear Amplifier

Table 1-1: Feature Summary

Standard Features	
• 85-240 VAC; 50-60 Hz control supply	<a href="#">Section 2.1.1.</a>
• ±40 VDC max motor supply	<a href="#">Section 2.1.2.</a>
• Two HyperWire ports	<a href="#">Section 2.2.</a>
• Dual-Axis PSO firing	<a href="#">Section 2.3.</a>
• Three-axis Part-Speed PSO firing that uses the PSO firing circuit based off of the commanded vector velocity of up to three axes	Refer to the online Help
• Two auxiliary channels of 40 MHz line driver quadrature encoder inputs	<a href="#">Section 2.7.</a>
• Four optically-isolated digital outputs; 5-24V	<a href="#">Section 2.6.1.</a>
• Four optically-isolated digital inputs; 5-24V	<a href="#">Section 2.6.2.</a>
• Two 16-bit single-ended analog outputs; ±10 V	<a href="#">Section 2.6.3.</a>
• One 16-bit differential analog input; ±10 V	<a href="#">Section 2.6.4.</a>
• Dedicated 5-24V Emergency Stop sense input	<a href="#">Section 2.7.1.</a>
• Two Sync ports	<a href="#">Section 2.9.</a>

The block diagram that follows shows a summary of the connector signals.

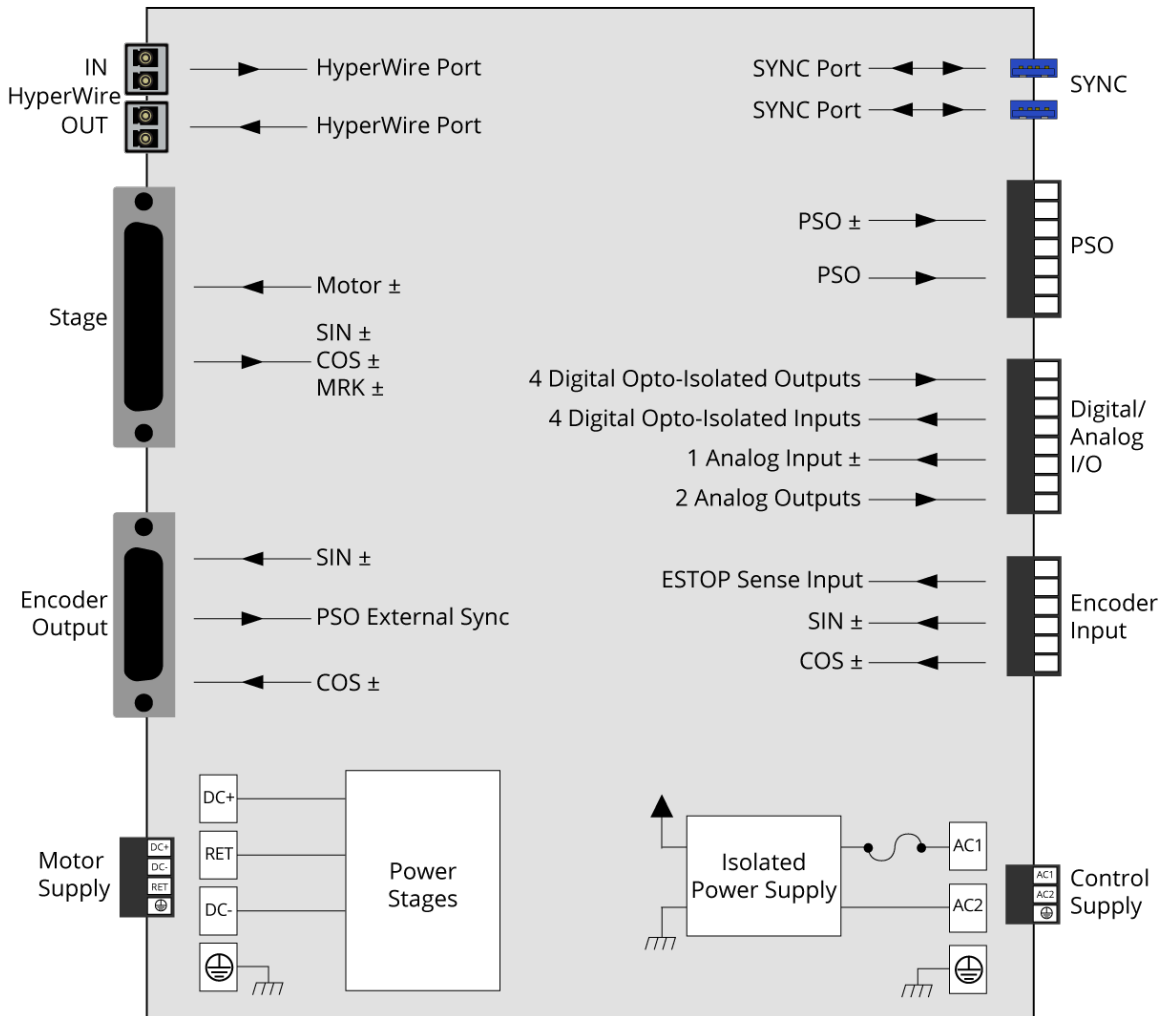

Figure 1-2: Functional Diagram



## 1.1. Electrical Specifications

**Table 1-2: Electrical Specifications**

Description		XL4s
Motor Supply	Input Voltage	±40 VDC (max)
	Input Current (continuous)	10 A
Control Supply	Input Voltage	85-240 VAC
	Input Frequency	50-60 Hz
	Inrush Current	16 A
	Input Current	0.35 A (max)
Output Voltage		76 V
Peak Output Current		20 A
Continuous Output Current		5 A
Minimum Load Resistance		0.5 Ω
User Power Supply Output		5 VDC (@ 500 mA)

## 1.2. Mechanical Specifications

### 1.2.1. Mounting and Cooling

Install the XL4s in an IP54 compliant enclosure to comply with safety standards. Make sure that there is sufficient clearance surrounding the drive for free airflow and for the cables and connections.

**Table 1-3: Mounting Specifications**

		XL4s
Customer-Supplied Enclosure		IP54 Compliant
Weight		~2.9 kg
Mounting Hardware		M4 [#8] screws (four locations, not included)
Mounting Orientation		Vertical (typical)
Dimensions		Refer to <a href="#">Section 1.2.2. Dimensions</a>
Minimum Clearance	Airflow	~25 mm
	Connectors	~100 mm
Operating Temperature		Refer to <a href="#">Section 1.3. Environmental Specifications</a>

1.2.2. Dimensions

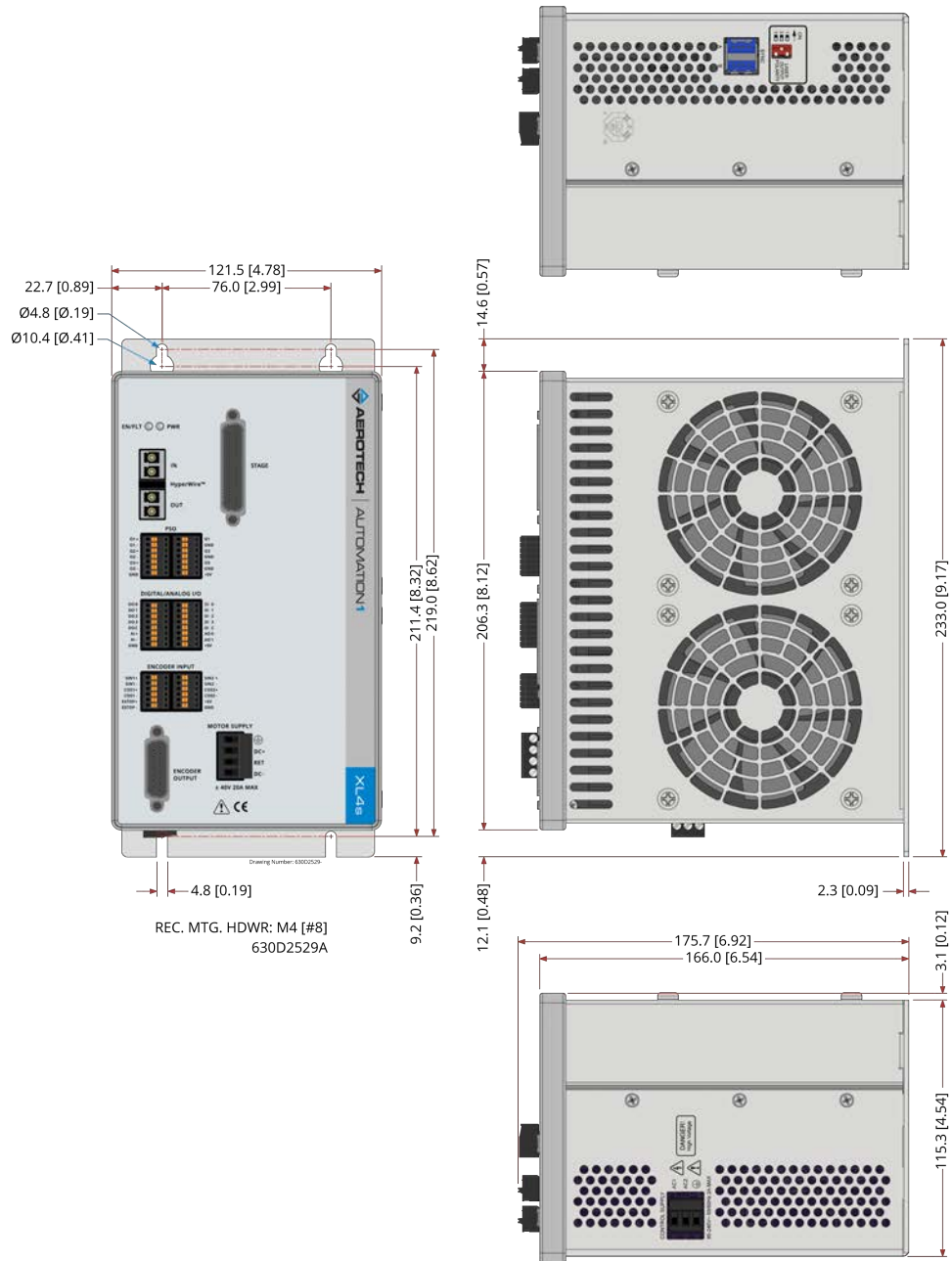

Figure 1-3: Dimensions

## 1.3. Environmental Specifications

**Table 1-4: Environmental Specifications**

<b>Ambient Temperature</b>	Operating: 0° to 40°C (32° to 104° F)
	Storage: -30° to 85°C (-22° to 185° F)
<b>Humidity Non-condensing</b>	The maximum relative humidity is 80% for temperatures that are less than 31°C and decreases linearly to 50% relative humidity at 40°C.
<b>Operating Altitude</b>	0 m to 2,000 m (0 ft to 6,562 ft) above sea level.
	If you must operate this product above 2,000 m or below sea level, contact Aerotech, Inc.
<b>Pollution</b>	Pollution Degree 2
	Typically only nonconductive pollution occurs.
<b>Operation</b>	Use only indoors

## 1.4. Drive and Software Compatibility

This table shows the available drives and which version of the software first supported each drive. In the **Last Software Version** column, drives that show a specific version number are not supported after that version.

**Table 1-5: Drive and Software Compatibility**

Drive Type	Software	First Software Version	Last Software Version
Automation1 XL4s	Automation1	1.0.0	Current
	A3200	6.04.000	Current

*This page intentionally left blank.*

## Chapter 2: Installation and Configuration

### Unpacking the Chassis



**IMPORTANT:** All electronic equipment and instrumentation is wrapped in antistatic material and packaged with desiccant. Ensure that the antistatic material is not damaged during unpacking.

Inspect the container of the XL4s for any evidence of shipping damage. If any damage exists, notify the shipping carrier immediately.

Remove the packing list from the XL4s container. Make sure that all the items specified on the packing list are contained within the package.

The documentation for the XL4s is on the included installation device. The documents include manuals, interconnection drawings, and other documentation pertaining to the system. Save this information for future reference. Additional information about the system is provided on the Serial and Power labels that are placed on the XL4s chassis.

The system serial number label contains important information such as the:

- Customer order number (please provide this number when requesting product support)
- Drawing number
- System part number

## 2.1. Input Power Connections

The XL4s has two input power connectors. One connector is for AC control power and the other connector is for DC motor power. For a full list of electrical specifications, refer to [Section 1.1](#).

### 2.1.1. Control Supply Connector



**IMPORTANT:** To operate correctly, this product must have a power supply connected to the Motor Supply and a power supply connected to the Control Supply.

The Control Supply input supplies power to the communications and logic circuitry of the XL4s. The AC1 input and the AC2 input are connected to fuses inside the XL4s. Refer to [Table 3-5](#) for fuse values and part numbers.

The Control Supply contains an internal filter. It is not necessary to use an external filter for CE compliance.



**IMPORTANT:** Refer to local electrical safety requirements to correctly size external system wires.



**DANGER:** Before you operate the XL4s, install a ground connection for your safety and to prevent damage to the equipment.

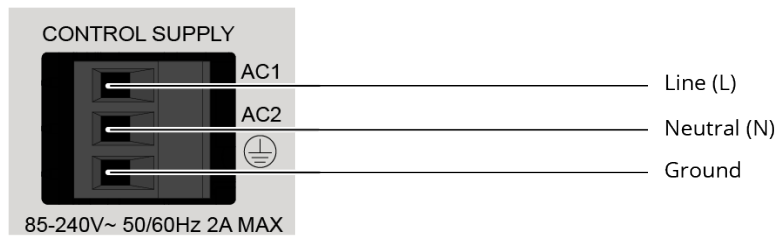

Figure 2-1: Control Supply Connections

Table 2-1: Control Supply Connector Wiring Specifications

Pin	Description	Recommended Wire Size <sup>(1)</sup>
AC1	Line Input: 85 - 240 Volt AC Input Range	1.3 mm <sup>2</sup> [#16 AWG]
AC2	Neutral (0V) or 85 - 240 Volt AC Input Range	1.3 mm <sup>2</sup> [#16 AWG]
	Protective Ground	1.3 mm <sup>2</sup> [#16 AWG]

(1)The wire insulation is rated for 300 V.

Table 2-2: Mating Connector Part Numbers for the Control Supply Connector

Type	Aerotech P/N	Third Party P/N	Screw Torque: N·m	Wire Size: mm <sup>2</sup> [AWG]
3-Pin Terminal Block	ECK00213	Phoenix 1754465	0.5 - 0.6	3.3 - 0.516 [12-30]



### 2.1.2. Motor Supply Connector



**IMPORTANT:** To operate correctly, this product must have a power supply connected to the Motor Supply and a power supply connected to the Control Supply.

Motor power is applied to the XL4s at the four terminals of the Motor Supply connector. The DC+ input and the DC- input are connected to fuses inside the XL4s. Refer to [Table 3-5](#) for fuse values and part numbers.



**IMPORTANT:** Refer to local electrical safety requirements to correctly size external system wires.



**DANGER:** To prevent the risk of electric shock, do not operate the XL4s without a ground connection.

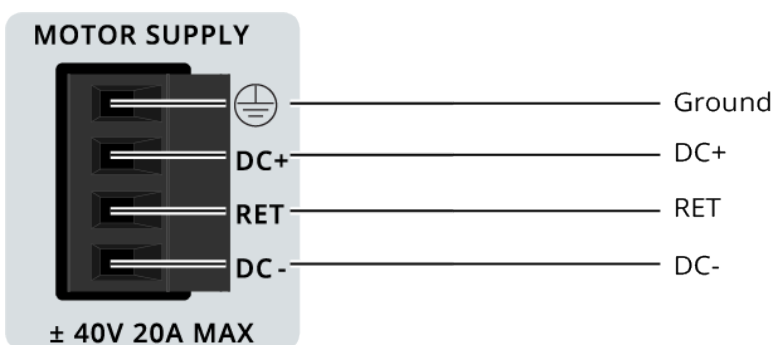



Figure 2-2: Motor Supply Connections

Table 2-3: Motor Supply Wiring Specifications

Pin	Description	Recommended Wire Size <sup>(1)</sup>
DC+	+40 VDC Input Range	2.1 mm <sup>2</sup> (#14 AWG)
RET	Return for DC Input	2.1 mm <sup>2</sup> (#14 AWG)
DC-	-40 VDC Input Range	2.1 mm <sup>2</sup> (#14 AWG)
	Protective Ground	2.1 mm <sup>2</sup> (#14 AWG)

(1)The wire insulation is rated for 300 V.

Table 2-4: Mating Connector Part Numbers for the Motor Supply Connector

Type	Aerotech P/N	Third Part P/N	Screw Torque: N·m	Wire Size: mm <sup>2</sup> [AWG]
4-Pin Terminal Block	ECK01581	Phoenix 1757035	0.5 - 0.6	3.3 - 0.0516 [12-30]

### 2.1.3. External Power Supply Options

You must connect the Motor Supply to a bipolar power supply. Aerotech recommends that you use an Aerotech TM3 transformer which can supply power to a maximum of four controllers ([Figure 2-3](#)).

As an alternative to a bipolar power supply, you can use two third-party power supplies but they must obey these conditions ([Figure 2-4](#)).

- The output of each power supply must not be ground referenced.
- The output of each power supply must be specified to be used in positive or negative polarity.

The XL4s controller can source 10 A peak current to each motor. This current must be supplied by the external power supply. A switching power supply must be rated for the peak current requirement of the system because the switching power supply might shut down if it is overloaded.

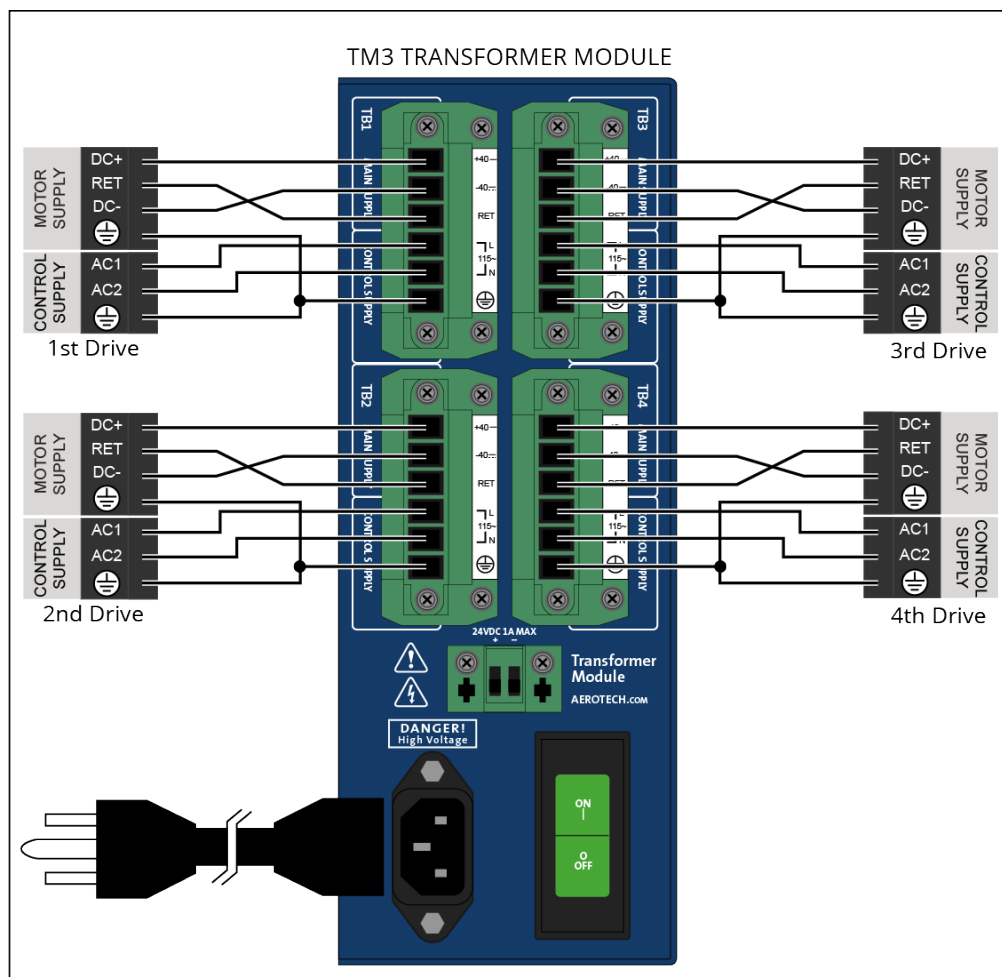

⚠ HAZARDOUS VOLTAGES PRESENT    
 ⚠ CONNECT ALL WIRING BEFORE POWERING TRANSFORMER    
 ⚠ FOLLOW ALL APPLICABLE WIRING AND SAFETY CODES.

1. The TM3 must be configured for a bipolar bus (-40B AUX AC).
2. The TM3 depicted is labeled for 115V line voltage (230V TM3 option available).
3. Transformer Wiring: 1.3 mm<sup>2</sup> (#16 AWG) 300 V wire.

**Figure 2-3: Control and Motor Power Wiring using a TM3 Transformer**

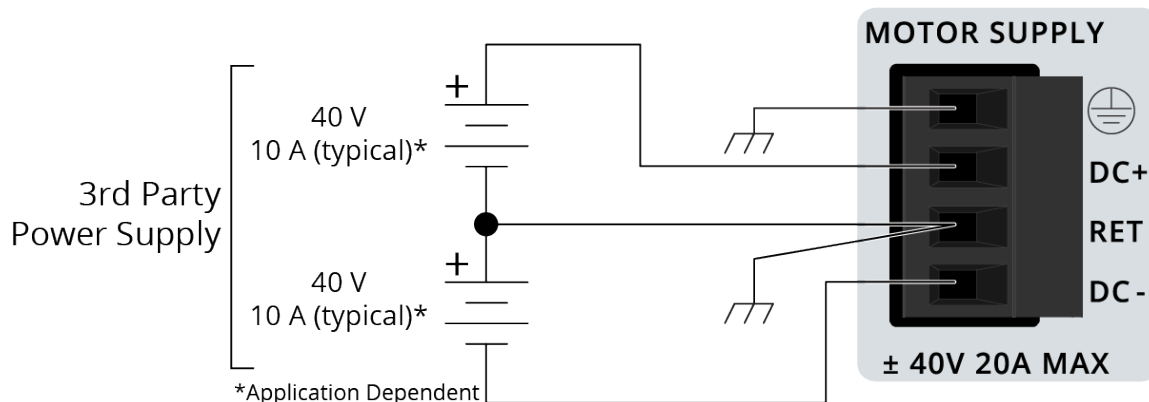

\*Application Dependent

**Figure 2-4: Third-Party Power Supply Connection**

### 2.1.4. Minimizing Noise for EMC/CE Compliance



**IMPORTANT:** The XL4s is a component designed to be integrated with other electronics. EMC testing must be conducted on the final product configuration.

To reduce electrical noise, observe the following motor feedback and input power wiring techniques.

1. Separate motor and power wiring from encoder and I/O wiring.
2. Mount drives, power supplies, and filter components on a conductive panel. Mount line filters close to the drive to keep the wire length between the drive and filter to a minimum. Use a line filter, such as Aerotech's UFM-ST, on the Control Supply AC inputs.

The following additional changes could be required for EMC compliance and are recommended during initial EMC system evaluation.

1. Add a clamp-on ferrite to the motor feedback cable close to the drive.  
[Aerotech PN ECZ02348, Fair-rite PN 0446167281]
2. Add a ferrite core to the UFM-ST AC input wires. Wrap the AC wires and ground wire around the core one time.  
[Ferrite core: Aerotech PN ECZ02350, Fair-rite PN 2646102002]

## 2.2. HyperWire Interface

The HyperWire bus is the high-speed communications connection to the XL4s operating at 2 gigabits per second. The PC sends all command and configuration information through the HyperWire bus.

HyperWire cables can be safely connected to or disconnected from a HyperWire port while the PC and/or drive is powered on. However, any changes to the HyperWire network topology will disrupt communication and you must reset the controller to re-establish communication.



**WARNING:** Do not connect or disconnect HyperWire cables while you are loading firmware or damage to the drives may occur.

**Table 2-5: HyperWire Card Part Number**

Part Number	Description
HYPERWIRE-PCIE	HyperWire adapter, PCIe x4 interface

**Table 2-6: HyperWire Cable Part Numbers**

Part Number	Description
HYPERWIRE-AO10-5	HyperWire cable, active optical, 0.5 m
HYPERWIRE-AO10-10	HyperWire cable, active optical, 1.0 m
HYPERWIRE-AO10-30	HyperWire cable, active optical, 3.0 m
HYPERWIRE-AO10-50	HyperWire cable, active optical, 5.0 m
HYPERWIRE-AO10-200	HyperWire cable, active optical, 20.0 m

## 2.3. Position Synchronized Output Connector

Program the Position Synchronized Output (PSO) to generate an output that is synchronized to the feedback position of an axis. PSO is typically used to fire a laser or trigger an external hardware device.

A PSO firing event can be triggered from a feedback channel or from a software trigger. You can get quadrature signals from feedback channels and PSO firing event signals after a PSO firing event occurs. When the PSO generates pulses, minimum latency occurs between the trigger condition and the output.

Aerotech recommends that you use an RS-422 line receiver or an opto-isolator if your system:

- Uses cables with long lengths in work areas where a lot of electrical noise occurs.
- Uses high-frequency pulse transmission.

For best performance, put the RS-422 line receiver or the opto-isolator near the electronics that receive the PSO output pulse.

**Table 2-7: PSO Connector A Pinout**

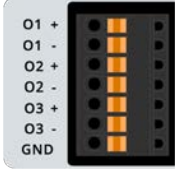
Pin #	Label	Description	In/Out/BI	Connector
1	O1+	PSO Output	Output	
2	O1-	PSO Output	Output	
3	O2+	Reserved	N/A	
4	O2-	Reserved	N/A	
5	O3+	Reserved	N/A	
6	O3-	Reserved	N/A	
7	GND	Ground	N/A	

**Table 2-8: PSO Connector B Pinout**

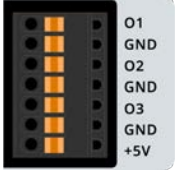
Pin #	Label	Description	In/Out/BI	Connector
1	O1	PSO Output (5V TTL)	Output	
2	GND	Ground	N/A	
3	O2	Reserved	N/A	
4	GND	Ground	N/A	
5	O3	Reserved	N/A	
6	GND	Ground	N/A	
7	+5V	5 Volt Power Supply (500 mA)	N/A	

**Table 2-9: Mating Connector Part Numbers for the PSO Connectors**

Type	Aerotech P/N	Third Party P/N	Wire Size: mm <sup>2</sup> [AWG]
7-Pin Terminal Block	ECK01631	Phoenix 1881370	0.5 - 0.080 [20-28]

**Table 2-10: PSO Specifications**

Specification		Value
Maximum PSO Output (Fire) Frequency	TTL	12.5 MHz
	Isolated	5 MHz
Output Latency [Fire event to output change]	TTL	50 ns
	Isolated	150 ns

1. Signals in excess of this rate will cause a loss of PSO accuracy

## 2.4. Encoder Output Connector

The Encoder Output interface echos the encoder signals out of the axis.

**Table 2-11: Encoder Output Connector Pinout**

Pin	Description	In/Out/Bi	Connector
1	SIN-	Output	
2	Reserved	N/A	
3	COS-	Output	
4	Reserved	N/A	
5	Reserved	N/A	
6	Reserved	N/A	
7	PSO External Sync	Input	
8	+5V	N/A	
9	SIN+	Output	
10	Reserved	N/A	
11	COS+	Output	
12	Reserved	N/A	
13	Reserved	N/A	
14	Reserved	N/A	
15	Ground	N/A	

**Table 2-12: Mating Connector Part Numbers for the Encoder Output Connector**

Mating Connector	Aerotech P/N	Third Party P/N
15-Pin D-Connector	ECK00100	Amphenol DA15P064TXLF
Backshell	ECK01022	Amphenol 17E-1725-2

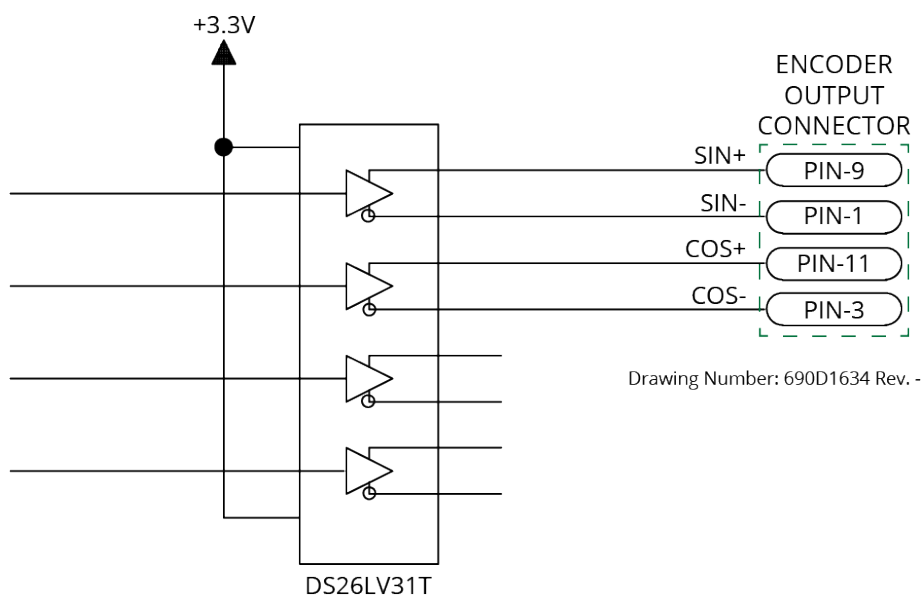
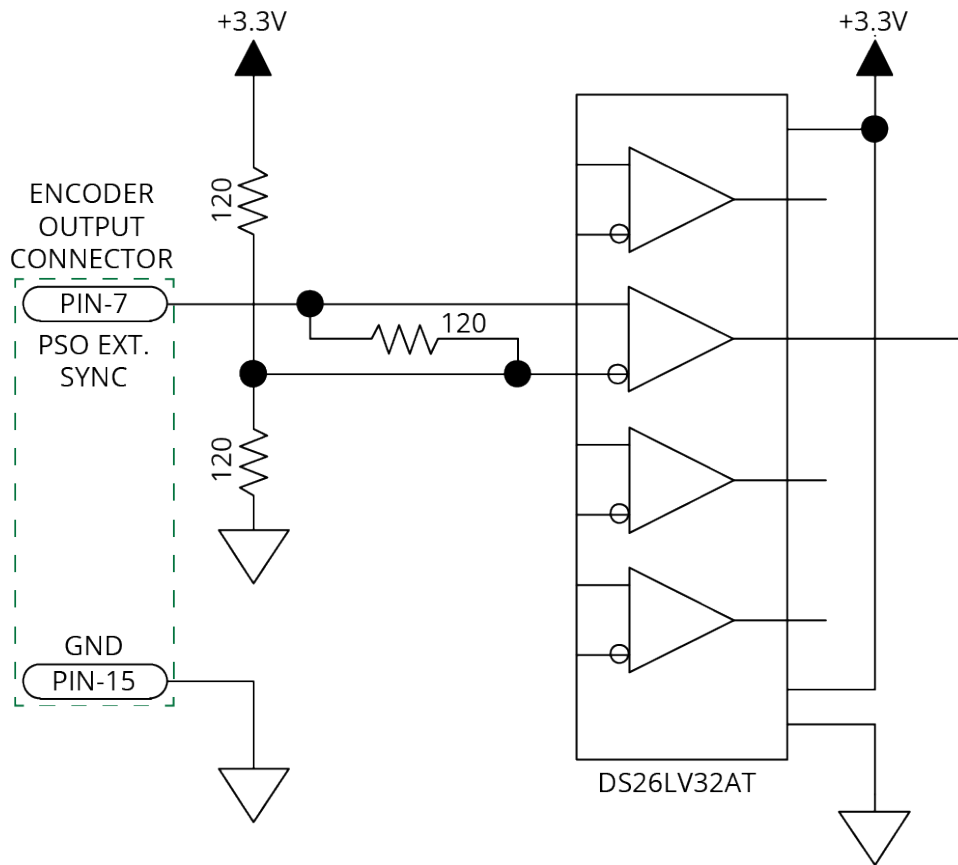

**Figure 2-5: Encoder Outputs Schematic**

You can use the external PSO synchronization functions [A3200: PSOOUTPUT PULSE EXTSYNC command] to synchronize waveform generation with an external synchronization signal. When you activate this feature, the PSO Waveform module will not generate the configured waveform when an output event is received until the rising edge of the synchronization signal occurs.

**Table 2-13: PSO External Sync Specifications**

Specification	Value
Voltage	3.3 VDC
Frequency	25 MHz Maximum
On Time	20 ns Minimum



**Figure 2-6: PSO External Sync Input Schematic**



## 2.5. Stage Motor and Feedback Connector

You can only use the XL4s to control a DC Brush motor.

**Table 2-14: Stage Motor and Feedback Connector Pinout**

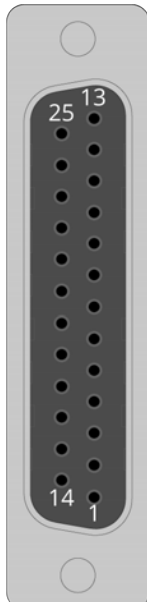
Pin	Description	In/Out/Bi	Pin Location
1	Sine +	Input	
2	Cosine +	Input	
3	Encoder Ground	N/A	
4	Reserved	N/A	
5	Reserved	N/A	
6	Reserved	N/A	
7	Marker +	Input	
8	Encoder Power (+5V, 500 mA)	N/A	
9	Reserved	N/A	
10	Flash Configuration	Input	
11	Frame Ground	N/A	
12	Motor +	Output	
13	Motor +	Output	
14	Sine -	Input	
15	Cosine -	Input	
16	Encoder Ground	N/A	
17	Reserved	N/A	
18	Reserved	N/A	
19	Reserved	N/A	
20	Marker -	Input	
21	Encoder Ground	N/A	
22	Reserved	N/A	
23	Frame Ground	N/A	
24	Motor -	Output	
25	Motor -	Output	

**Table 2-15: Mating Connector Part Numbers for the Stage Motor and Feedback Connector**

Mating Connector	Aerotech P/N	Third Party P/N
25-Pin D-Connector	ECK00101	FCI DB25P064TXLF
Backshell	ECK00656	Amphenol 17E-1726-2

### 2.5.1. Analog Encoder Inputs

The XL4s has one analog encoder input channel. The XL4s uses this input channel for position feedback. Use Encoder Tuning [A3200: Feedback Tuning] to adjust the value of the gain, offset, and phase balance controller parameters to get the best performance. For more information, refer to the Help file.

**Table 2-16: Analog Encoder Input Specifications**

Specification	Value
Input Frequency (max)	500 kHz
Input Amplitude <sup>(1)</sup>	0.6 to 1.2 Vpk-pk
Interpolation Factor (max)	262,144
Input Common Mode	1.5 to 3.5 VDC

(1) Any single-ended encoder signal measured with respect to ground.

## 2.6. Digital and Analog I/O Connectors

This connector has four digital, optically-isolated outputs, four digital, optically-isolated inputs, one differential analog input, and two analog outputs.

**Table 2-17: Digital and Analog I/O Connector A Pinout**

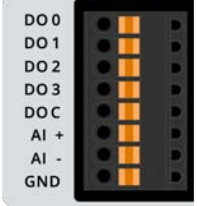
Pin #	Label	Description	In/Out/Bi	Connector
1	DO0	Digital Output 0 (Optically-Isolated)	Output	
2	DO1	Digital Output 1 (Optically-Isolated)	Output	
3	DO2	Digital Output 2 (Optically-Isolated)	Output	
4	DO3	Digital Output 3 (Optically-Isolated)	Output	
5	DOC	Digital Output Common	Input	
6	AI+	Analog Input +	Input	
7	AI-	Analog Input -	Input	
8	GND	Ground	N/A	

**Table 2-18: Digital and Analog I/O Connector B Pinout**

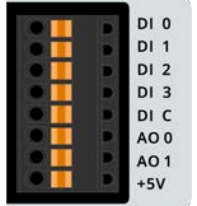
Pin #	Label	Description	In/Out/Bi	Connector
1	DI0	Digital Input 0 (Optically-Isolated)	Input	
2	DI1	Digital Input 1 (Optically-Isolated)	Input	
3	DI2	Digital Input 2 (Optically-Isolated)	Input	
4	DI3	Digital Input 3 (Optically-Isolated)	Input	
5	DIC	Digital Input Common	Input	
6	AO0	Analog Output 0	Output	
7	AO1	Analog Output 1	Output	
8	+5V	+5V	N/A	

**Table 2-19: Mating Connector Part Numbers for the Digital / Analog I/O Connectors**

Mating Connector	Aerotech P/N	Third Party P/N	Wire Size: mm <sup>2</sup> [AWG]
8-Pin Terminal Block	ECK01386	Phoenix 1881383	0.5 - 0.080 [20-28]

### 2.6.1. Digital Outputs

Optically-isolated solid-state relays drive the digital outputs. You can connect the digital outputs in current sourcing or current sinking mode but you must connect all four outputs in the same configuration. Refer to [Figure 2-7](#) and [Figure 2-8](#).

You must install suppression diodes on digital outputs that drive relays or other inductive devices. To see an example of a current sourcing output that has diode suppression, refer to [Figure 2-7](#). To see an example of a current sinking output that has diode suppression, refer to [Figure 2-8](#).

The digital outputs are not designed for high-voltage isolation applications and they should only be used with ground-referenced circuits.

The digital outputs have overload protection. They will resume normal operation when the overload is removed.

**Table 2-20: Digital Output Specifications**

Digital Output Specifications	Value
Maximum Voltage	24 V (26 V Maximum)
Maximum Sink/Source Current	50 mA/output
Output Saturation Voltage	0.2 V at maximum current
Output Resistance	4 $\Omega$
Rise / Fall Time	250 $\mu$ s (2K pull up to 24V)
Reset State	Output Off (High Impedance State)

**Table 2-21: Digital Output Pins on the Digital/Analog I/O A Connector**

Pin #	Label	Description	In/Out/Bi
1	DO0	Digital Output 0 (Optically-Isolated)	Output
2	DO1	Digital Output 1 (Optically-Isolated)	Output
3	DO2	Digital Output 2 (Optically-Isolated)	Output
4	DO3	Digital Output 3 (Optically-Isolated)	Output
5	DOC	Digital Output Common	Input

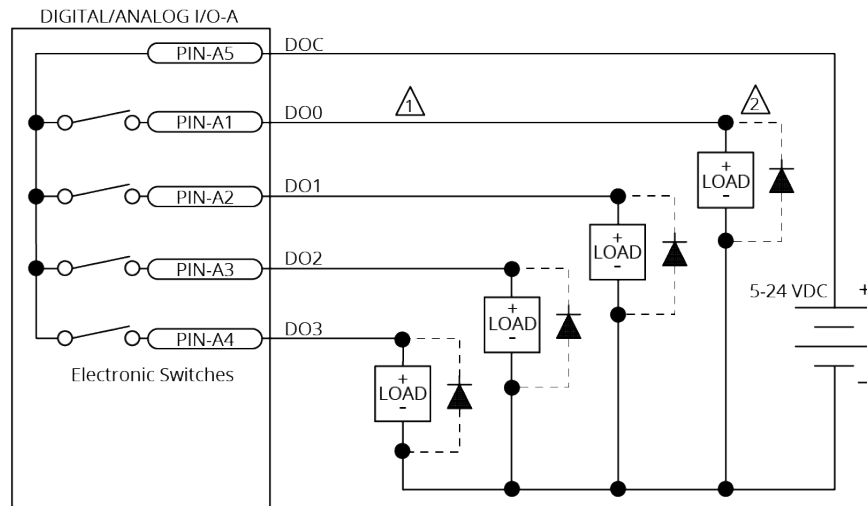

1 Each output 50 mA maximum  
 2 Diode required on each output that drives an inductive device (coil), such as a relay.  
**Figure 2-7: Digital Outputs Connected in Current Sourcing Mode**

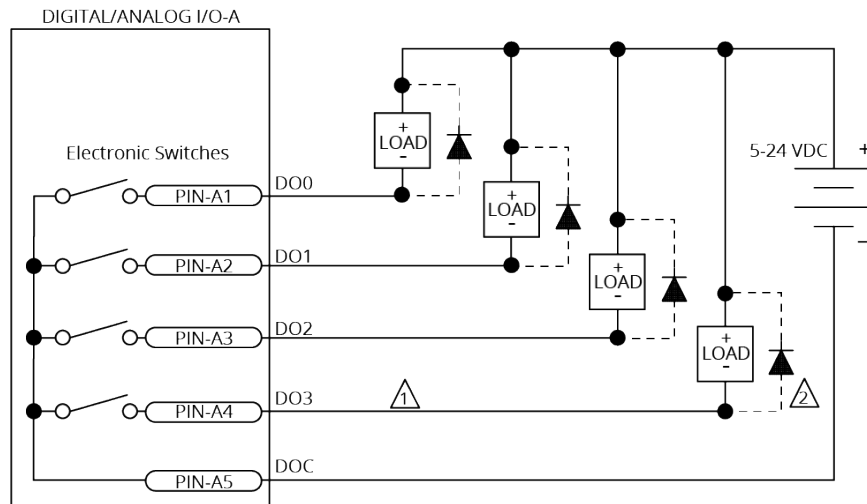

1 Each output 50 mA maximum  
 2 Diode required on each output that drives an inductive device (coil), such as a relay.  
**Figure 2-8: Digital Outputs Connected in Current Sinking Mode**

## 2.6.2. Digital Inputs

You can connect the digital inputs to current sourcing or current sinking devices but you must connect all four inputs in the same configuration. Refer to [Figure 2-10](#) and [Figure 2-9](#). The digital inputs are not designed for high-voltage isolation applications. They should only be used with ground-referenced circuits.

**Table 2-22: Digital Input Specifications**

Input Voltage	Approximate Input Current	Turn On Time	Turn Off Time
+5 V to +24 V	6 mA	10 $\mu$ s	43 $\mu$ s

**Table 2-23: Digital Input Pins on the Digital/Analog I/O B Connector**

Pin #	Label	Description	In/Out/Bi
1	DI0	Digital Input 0 (Optically-Isolated)	Input
2	DI1	Digital Input 1 (Optically-Isolated)	Input
3	DI2	Digital Input 2 (Optically-Isolated)	Input
4	DI3	Digital Input 3 (Optically-Isolated)	Input
5	DIC	Digital Input Common	Input

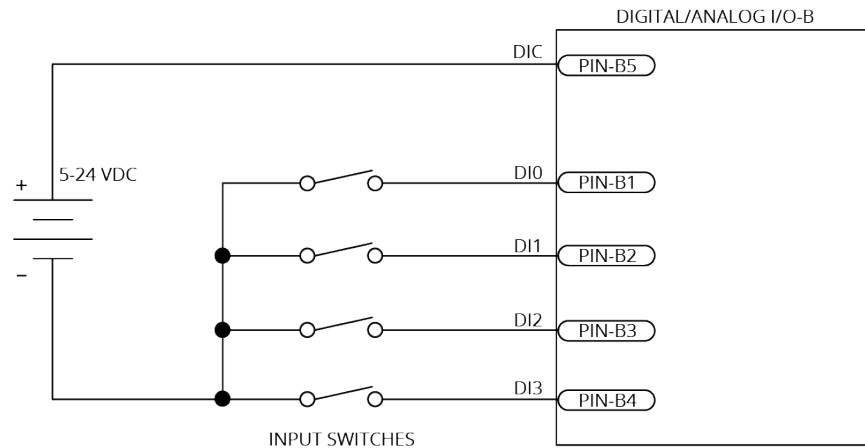

**Figure 2-9: Digital Inputs Connected to Current Sinking Devices**

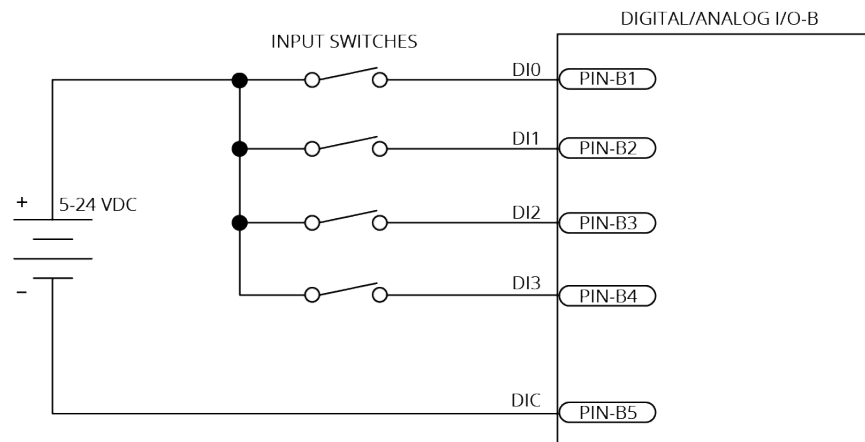

**Figure 2-10: Digital Inputs Connected to Current Sourcing Devices**

### 2.6.3. Analog Outputs

The analog output is set to zero when you power on the system or reset the drive.

**Table 2-24: Analog Output Specifications**

Specification	Value
Output Voltage	-10 V to +10 V
Output Current	5 mA
Resolution (bits)	16 bits

**Table 2-25: Analog Output Pins on the Digital / Analog I/O B Connector**

Pin #	Label	Description	In/Out/Bi
6	AO0	Analog Output 0	Output
7	AO1	Analog Output 1	Output

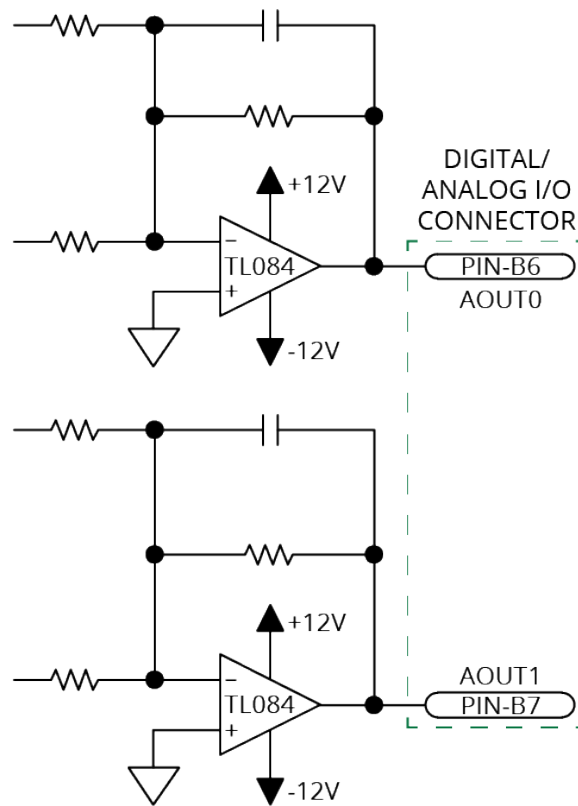

**Figure 2-11: Analog Outputs Schematic**

### 2.6.4. Analog Inputs (Differential)

To interface to a single-ended, non-differential voltage source, connect the signal common of the source to the negative input and connect the analog source signal to the positive input. A floating signal source must be referenced to the analog common. Refer to [Figure 2-12](#).

**Table 2-26: Analog Input Specifications**

Specification	Value
(AI+) - (AI-)	+10 V to -10 V <sup>(1)</sup>
Resolution (bits)	16 bits
Input Impedance	1 MΩ
1. Signals outside of this range may damage the input	

**Table 2-27: Analog Input Pins on the Digital / Analog I/O B Connector**

Pin #	Label	Description	In/Out/Bi
6	AI+	Analog Input +	Input
7	AI-	Analog Input -	Input
8	GND	Ground	N/A

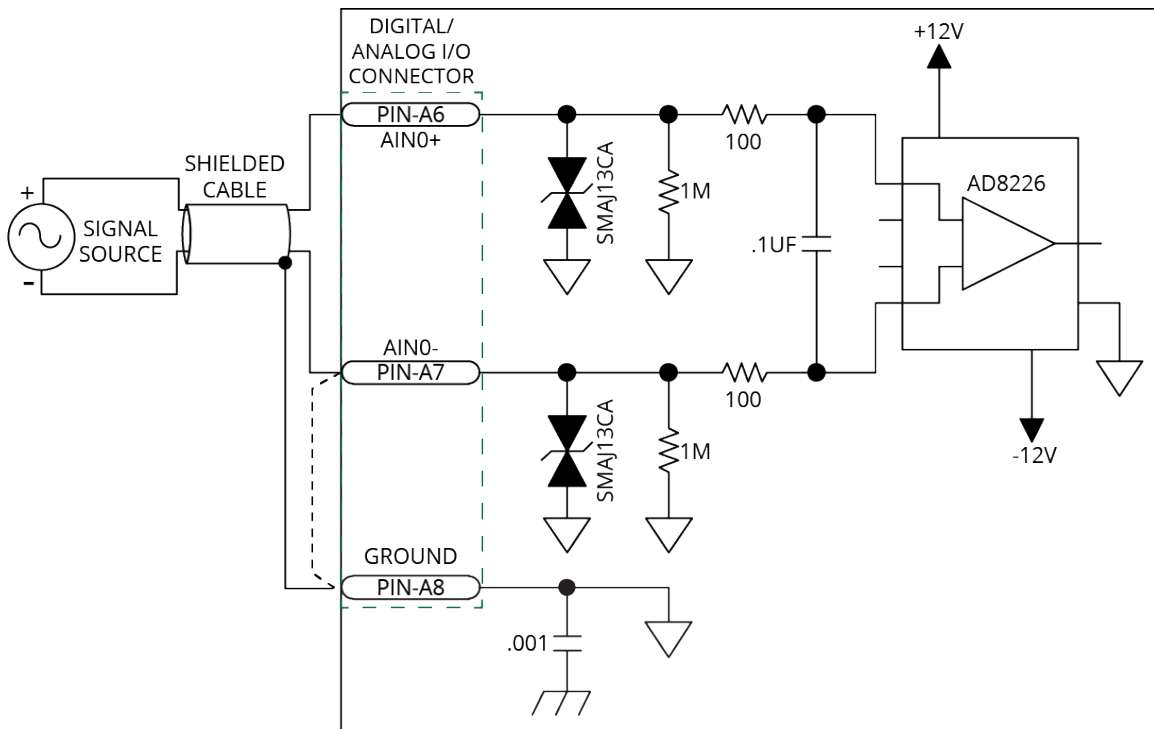

**Figure 2-12: Analog Inputs Schematic**



## 2.7. Encoder Input Connectors

The XL4s has one auxiliary encoder input channel. The encoder interface accepts an RS-422 differential line driver. You cannot use the auxiliary encoder input channels to close the position loop.

**Table 2-28: Encoder Input Connector Specifications**

Specification	Value
Encoder Frequency	10 MHz maximum (25 ns minimum edge separation)
x4 Quadrature Decoding	40 million counts/sec

**Table 2-29: Encoder Input Connector A Pinout**

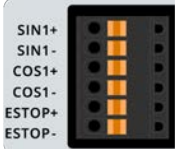
Pin	Label	Description	In/Out/Bi	Connector
1	SIN1+	Encoder SIN+ Input	Input	
2	SIN1-	Encoder SIN- Input	Input	
3	COS1+	Encoder COS+ Input	Input	
4	COS1-	Encoder COS- Input	Input	
5	ESTOP+	Emergency Stop Opto-Isolated Input +	Input	
6	ESTOP-	Emergency Stop Opto-Isolated Input -	Input	

**Table 2-30: Encoder Input Connector B Pinout**

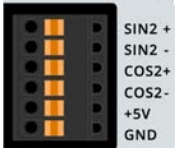
Pin	Label	Description	In/Out/Bi	Connector
1	SIN2+	Reserved	N/A	
2	SIN2-	Reserved	N/A	
3	COS2+	Reserved	N/A	
4	COS2-	Reserved	N/A	
5	+5V	+5V Encoder Power	N/A	
6	GND	Ground	N/A	

**Table 2-31: Mating Connector Part Numbers for the Encoder Input Connector**

Type	Aerotech P/N	Third Party P/N	Wire Size: mm <sup>2</sup> [AWG]
6-Pin Terminal Block	ECK02220	Phoenix 1881367	0.5 - 0.080 [20-28]

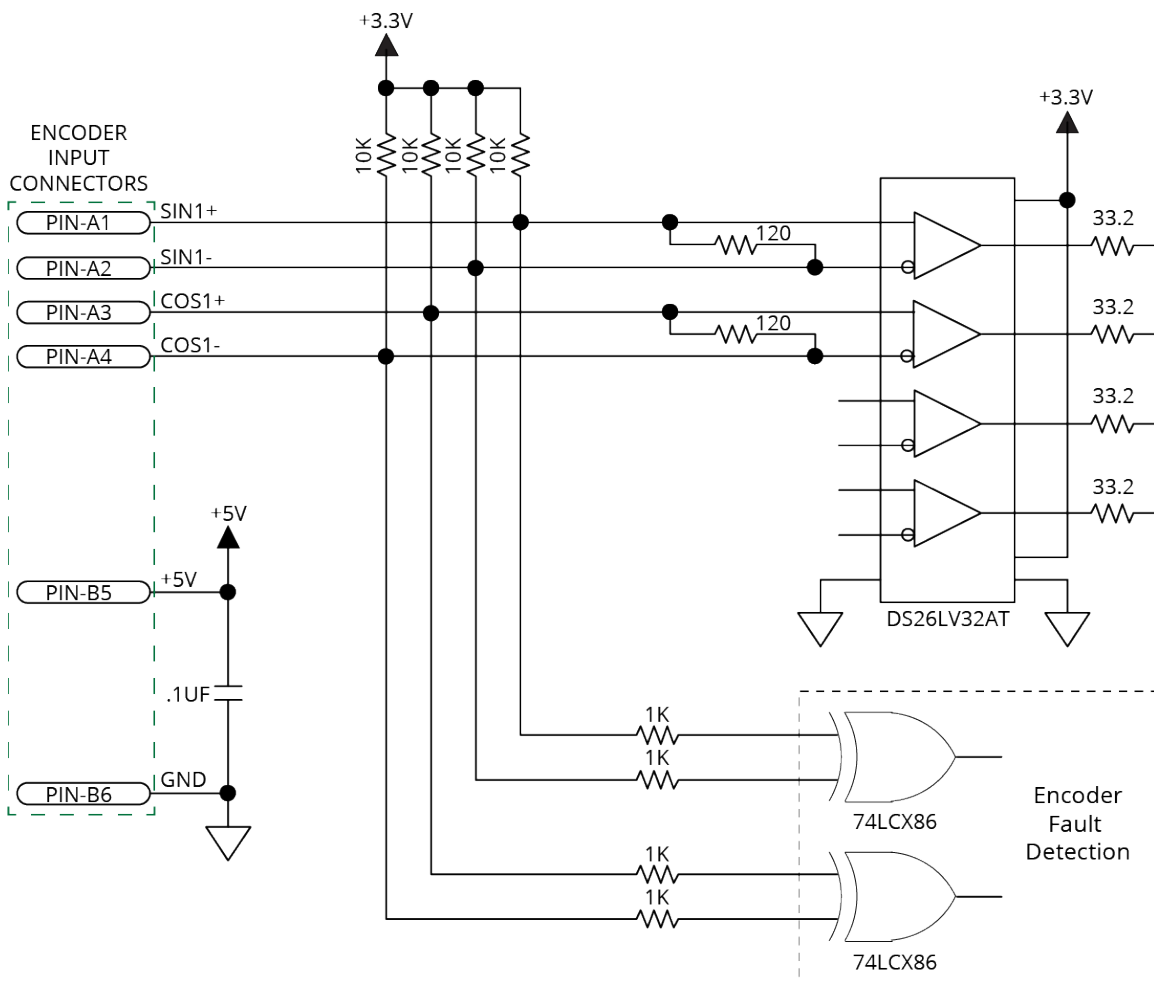

Figure 2-13: Encoder Input Connector Encoder Connections

### 2.7.1. Emergency Stop Sense Input



**WARNING:** It is your responsibility to assemble the external safety circuits of your system to minimize the risk to the operator.



**IMPORTANT:** The ESTOP sense input is not a safety-rated system.

Use the ESTOP sense input to monitor the state of an external safety circuit only. The software identifies this state by using the **Emergency Stop Input Level** bit of the Drive Status. To get the software to generate an ESTOP fault when power is removed at the ESTOP input, set the ESTOP bit in the FaultMask parameter.

The ESTOP input is scaled for an input voltage of 5 - 24 volts.

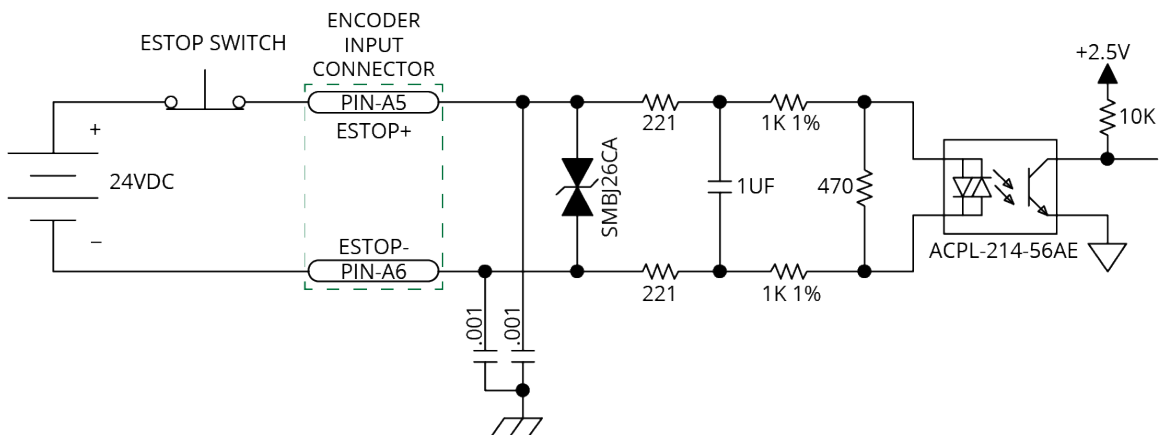

Figure 2-14: ESTOP Sense Input Schematic

Table 2-32: ESTOP Pins on the Encoder Input Connector

Pin #	Label	Description	In/Out/Bit
5	ESTOP+	Emergency Stop Digital Input +	Input
6	ESTOP-	Emergency Stop Digital Input -	Input



**IMPORTANT:** If you connect the ESTOP input to a device that makes electrical noise, you must connect an electrical noise suppression device across the switched coil. Refer to [Table 2-33](#) to see the types of devices you can use.

Table 2-33: Electrical Noise Suppression Devices

Device	Aerotech P/N	Third Party P/N
RC (.1uf / 200 ohm) Network	EIC00240	Electrocube RG1782-8
Varistor	EID00160	Littelfuse V250LA40A

## 2.8. Laser Output Polarity Switch

The Laser Output Polarity switches are reserved for future use.

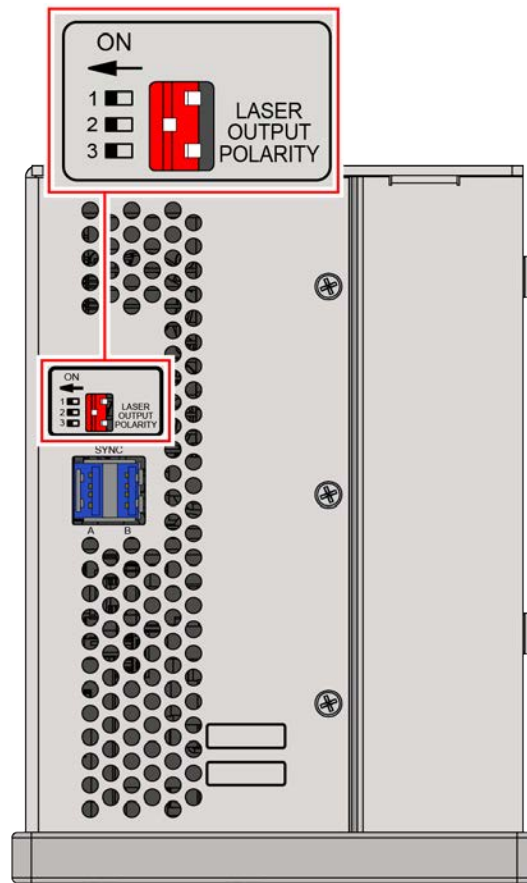

Figure 2-15: Laser Output Polarity Switch Location

## 2.9. Sync Port

The Sync port is a bi-directional high speed proprietary interface that lets you transmit encoder signals between drives. This is typically used for multi-axis PSO applications where one or two drives send their encoder signals to a main drive that has the PSO logic and PSO output signal. The XL4s contains two Sync ports, labeled A and B.

To avoid signal contention, all Sync ports default to the input state during reset and immediately after power is applied to the drive.

**Table 2-34: Sync-Related Functions**

Function	Description
DriveEncoderOutputConfigureDivider(), DriveEncoderOutputConfigureInput(), DriveEncoderOutputOn(), DriveEncoderOutputOff() [A3200: ENCODER OUT command]	Configure each Sync port as an input or an output
PsoDistanceConfigureInputs() [A3200: PSOTRACK INPUT command]	Let the PSO to track the SYNC A or SYNC B port.
PsoWindowConfigureInput() [A3200: PSOWINDOW INPUT command]	

The Sync port uses low-voltage differential signaling (LVDS) and standard USB 3.0 type A (cross over) cables.

**Table 2-35: Sync Port Cables**

Part Number	Description
CBL-SYNC-3	Length 3 dm; Connectors: USB Type A to USB Type A
CBL-SYNC-5	Length 5 dm; Connectors: USB Type A to USB Type A
CBL-SYNC-7	Length 7 dm; Connectors: USB Type A to USB Type A
CBL-SYNC-10	Length 10 dm; Connectors: USB Type A to USB Type A

## **2.10. PC Configuration and Operation Information**

For more information about hardware requirements, PC configuration, programming, system operation, and utilities, refer to the Help file.

## Chapter 3: Maintenance



**IMPORTANT:** For your own safety and for the safety of the equipment:

- Do not remove the cover of the XL4s
- Do not attempt to access the internal components.

A fuse that needs to be replaced indicates that there is a more serious problem with the system or setup. Contact Global Technical Support for assistance.



**DANGER:** If you must remove the covers and access any internal components be aware of the risk of electric shock.

1. Disconnect the Mains power connection.
2. Wait at least ten (10) minutes after removing the power supply before doing maintenance or an inspection. Otherwise, there is the danger of electric shock.
3. All tests must be done by an approved service technician. Voltages inside the controller and at the input and output power connections can kill you.

**Table 3-1: LED Description**

LED	Color	Description
PWR	GREEN	The light will illuminate and remain illuminated while power is applied.
EN/FLT	GREEN	The axis is Enabled.
	RED	The axis is in a Fault Condition.
	GREEN/RED (alternates)	The axis is Enabled in a Fault Condition. or The light is configured to blink for setup.

**Table 3-2: Troubleshooting**

Symptom	Possible Cause and Solution
No Communication	Make sure the power LED is illuminated (this indicates that power is present).
	Make sure that all communication cables (HyperWire, for example) are fully inserted in their ports.

### 3.1. Preventative Maintenance

Do an inspection of the XL4s and the external wiring one time each month. It might be necessary to do more frequent inspections based on:

- The operating conditions of the system.
- How you use the system.

**Table 3-3: Preventative Maintenance**

Check	Action to be Taken
Examine the chassis for hardware and parts that are damaged or loose. It is not necessary to do an internal inspection unless you think internal damage occurred.	Repair all damaged parts.
Do an inspection of the cooling vents.	Remove all material that collected in the vents.
Examine the work area to make sure there are no fluids and no electrically conductive materials.	Do not let fluids and electrically conductive material go into the XL4s.
Examine all cables and connections to make sure they are correct.	Make sure that all connections are correctly attached and not loose. Replace cables that are worn. Replace all broken connectors.

### Cleaning



**DANGER:** Before you clean the XL4s, disconnect the electrical power from the drive.

Use a clean, dry, soft cloth to clean the chassis of the XL4s. If necessary, you can use a cloth that is moist with water or isopropyl alcohol. If you use a moist cloth, make sure that moisture does not go into the XL4s. Also make sure that it does not go onto the outer connectors and components.

Do not use fluids and sprays to clean the XL4s because they can easily go into the chassis or onto the outer connectors and components. If a cleaning solution goes into the XL4s, internal contamination can cause corrosion and electrical short circuits.

Do not clean the labels with a cleaning solution because it might remove the label information.



### 3.2. Board Assembly

Figure 3-1 highlights the important components located on the control board.

 **DANGER:** Before you open the XL4s chassis, you must disconnect the Mains power connection.

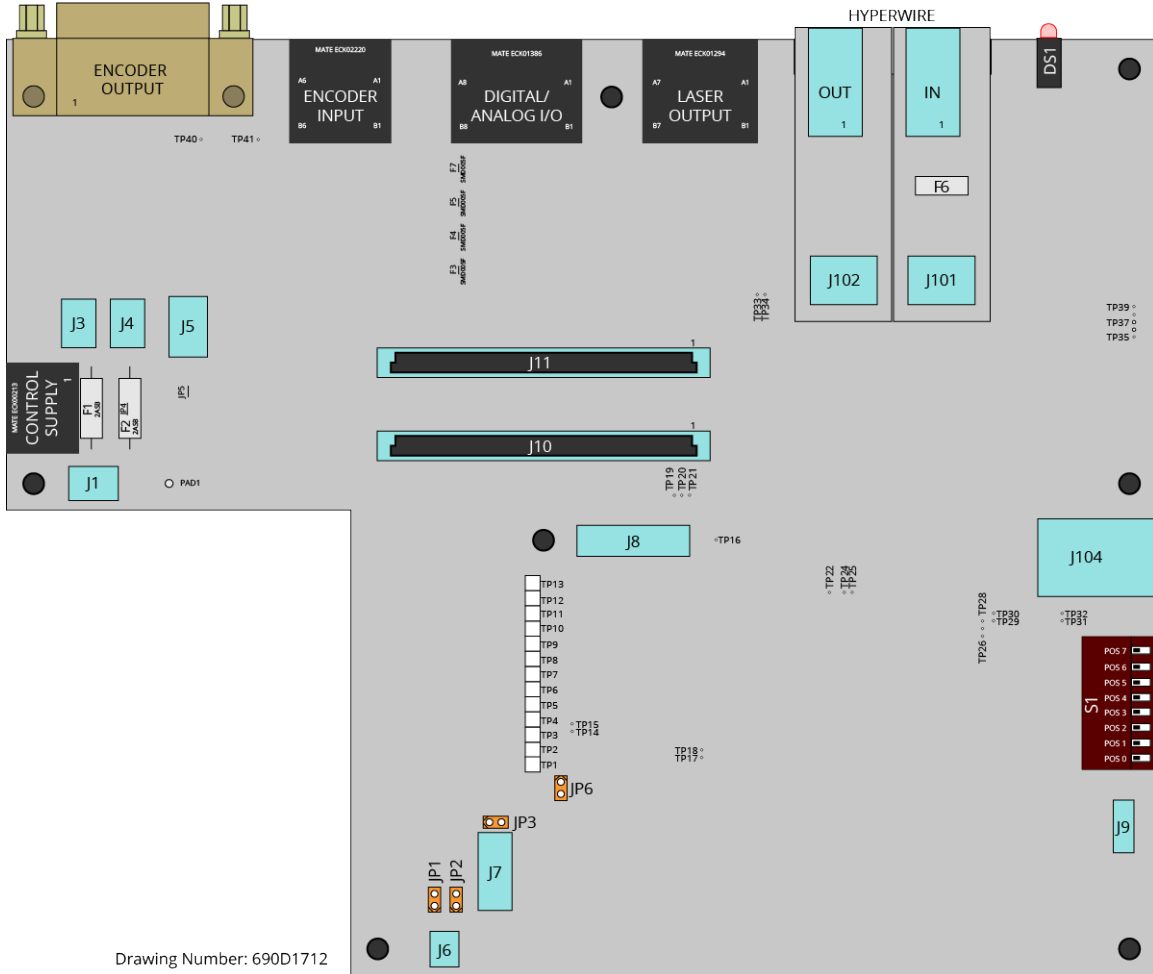

Figure 3-1: Control Board Assembly

Table 3-4: Control Board Fuse Specifications

Fuse	Description	Size	Aerotech P/N	Third Party P/N
F1	Control Supply Power at Pin-1	2 A S.B.	EIF01048	Littelfuse 0875002.MXEP
F2	Control Supply Power at Pin-1	2 A S.B.	EIF01048	Littelfuse 0875002.MXEP
F6	HyperWire power	--	--	--

NOTE: F6 is a resettable fuse. It is not necessary to replace the fuse. Turn off the power and remove the short circuit.



**DANGER:** Before you open the XL4s chassis, you must disconnect the Mains power connection.

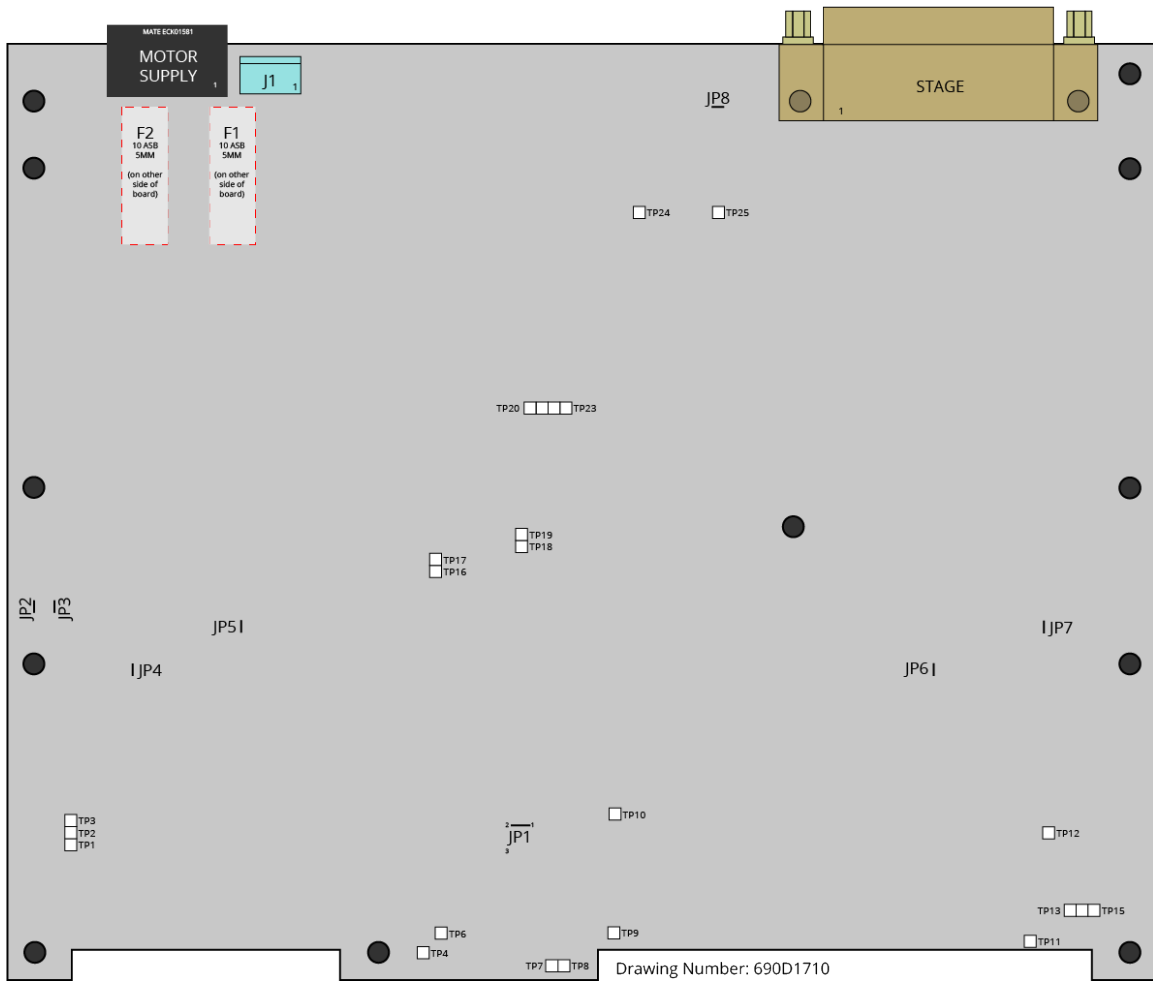

**Figure 3-2: Power Board Assembly**

**Table 3-5: Power Board Fuse Specifications**

Fuse	Description	Size	Aerotech P/N	Third Party P/N
F1	Motor Bus Supply	10 A S.B.	EF01020	Littelfuse 215010.P
F2	Motor Bus Supply	10 A S.B.	EF01020	Littelfuse 215010.P

NOTE: F1 and F2 are on the bottom of the board.

## Appendix A: Warranty and Field Service

Aerotech, Inc. warrants its products to be free from harmful defects caused by faulty materials or poor workmanship for a minimum period of one year from date of shipment from Aerotech. Aerotech's liability is limited to replacing, repairing or issuing credit, at its option, for any products that are returned by the original purchaser during the warranty period. Aerotech makes no warranty that its products are fit for the use or purpose to which they may be put by the buyer, whether or not such use or purpose has been disclosed to Aerotech in specifications or drawings previously or subsequently provided, or whether or not Aerotech's products are specifically designed and/or manufactured for buyer's use or purpose. Aerotech's liability on any claim for loss or damage arising out of the sale, resale, or use of any of its products shall in no event exceed the selling price of the unit.

THE EXPRESS WARRANTY SET FORTH HEREIN IS IN LIEU OF AND EXCLUDES ALL OTHER WARRANTIES, EXPRESSED OR IMPLIED, BY OPERATION OF LAW OR OTHERWISE. IN NO EVENT SHALL AEROTECH BE LIABLE FOR CONSEQUENTIAL OR SPECIAL DAMAGES.

### Return Products Procedure

Claims for shipment damage (evident or concealed) must be filed with the carrier by the buyer. Aerotech must be notified within thirty (30) days of shipment of incorrect material. No product may be returned, whether in warranty or out of warranty, without first obtaining approval from Aerotech. No credit will be given nor repairs made for products returned without such approval. A "Return Materials Authorization (RMA)" number must accompany any returned product(s). The RMA number may be obtained by calling an Aerotech service center or by submitting the appropriate request available on our website ([www.aerotech.com](http://www.aerotech.com)). Products must be returned, prepaid, to an Aerotech service center (no C.O.D. or Collect Freight accepted). The status of any product returned later than thirty (30) days after the issuance of a return authorization number will be subject to review.

Visit [Global Technical Support Portal](#) for the location of your nearest Aerotech Service center.

### Returned Product Warranty Determination

After Aerotech's examination, warranty or out-of-warranty status will be determined. If upon Aerotech's examination a warranted defect exists, then the product(s) will be repaired at no charge and shipped, prepaid, back to the buyer. If the buyer desires an expedited method of return, the product(s) will be shipped collect. Warranty repairs do not extend the original warranty period.

**Fixed Fee Repairs** - Products having fixed-fee pricing will require a valid purchase order or credit card particulars before any service work can begin.

**All Other Repairs** - After Aerotech's evaluation, the buyer shall be notified of the repair cost. At such time the buyer must issue a valid purchase order to cover the cost of the repair and freight, or authorize the product(s) to be shipped back as is, at the buyer's expense. Failure to obtain a purchase order number or approval within thirty (30) days of notification will result in the product(s) being returned as is, at the buyer's expense.

Repair work is warranted for ninety (90) days from date of shipment. Replacement components are warranted for one year from date of shipment.

### Rush Service

At times, the buyer may desire to expedite a repair. Regardless of warranty or out-of-warranty status, the buyer must issue a valid purchase order to cover the added rush service cost. Rush service is subject to Aerotech's approval.

### On-site Warranty Repair

If an Aerotech product cannot be made functional by telephone assistance or by sending and having the customer install replacement parts, and cannot be returned to the Aerotech service center for repair, and if Aerotech determines the problem could be warranty-related, then the following policy applies:

Aerotech will provide an on-site Field Service Representative in a reasonable amount of time, provided that the customer issues a valid purchase order to Aerotech covering all transportation and subsistence costs. For warranty field repairs, the customer will not be charged for the cost of labor and material. If service is rendered at times other than normal work periods, then special rates apply.

If during the on-site repair it is determined the problem is not warranty related, then the terms and conditions stated in the following "On-Site Non-Warranty Repair" section apply.

### On-site Non-Warranty Repair

If any Aerotech product cannot be made functional by telephone assistance or purchased replacement parts, and cannot be returned to the Aerotech service center for repair, then the following field service policy applies:

Aerotech will provide an on-site Field Service Representative in a reasonable amount of time, provided that the customer issues a valid purchase order to Aerotech covering all transportation and subsistence costs and the prevailing labor cost, including travel time, necessary to complete the repair.

### Service Locations

<http://www.aerotech.com/contact-sales.aspx?mapState=showMap>

#### **USA, CANADA, MEXICO**

Aerotech, Inc.  
Global Headquarters

#### **CHINA**

Aerotech China  
Full-Service Subsidiary

#### **GERMANY**

Aerotech Germany  
Full-Service Subsidiary

#### **TAIWAN**

Aerotech Taiwan  
Full-Service Subsidiary

#### **UNITED KINGDOM**

Aerotech United Kingdom  
Full-Service Subsidiary

## Appendix B: Revision History

Revision	Description
2.00	General Update
1.04	Updated <a href="#">Section 1.2. Mechanical Specifications</a>
1.03	Updated <a href="#">Table 1-1</a>
1.02	Updated to AUTOMATION1 hardware
1.01	Added <a href="#">Table 2-13</a>
1.00	New Manual

*This page intentionally left blank.*

# Index

	<b>2</b>		
2014/35/EU		7	
	<b>A</b>		
Agency Approvals		9	
Altitude		20	
Ambient Temperature		20	
Analog Encoder Input Specifications		34	
Analog Encoder Inputs		34	
Analog Input Pins on the Digital / Analog I/O B Connector		40	
Analog Input Specifications (Digital / Analog I/O B Connector)		40	
Analog Inputs (Digital / Analog I/O B Connector)		40	
Analog Inputs Schematic		40	
Analog Output Pins on the Digital / Analog I/O B Connector		39	
Analog Output Specifications (Digital and Analog I/O Connector)		39	
Analog Outputs (Digital and Analog I/O Connector)		39	
Analog Outputs Schematic		39	
	<b>B</b>		
Board Assembly		49	
	<b>C</b>		
Cables			
HyperWire		29	
Sync Port		45	
cables, examining		48	
CAN/CSA-C22.2 No. 61010-1		9	
Check for fluids or electrically conductive material exposure		48	
Cleaning		48	
Commands			
Sync		45	
connections, examining		48	
Continuous Output Current		17	
Control and Motor Power Wiring using a TM3 Transformer		27	
Control Board Assembly		49	
Control Board Fuse Specifications		49	
Control Supply		17	
Control Supply Connections		24	
Control Supply Connector		24	
Mating Connector Part Numbers		24	
Wiring Specifications		24	
cooling vents, inspecting		48	
Customer order number		23	
	<b>D</b>		
Declaration of Conformity		7	
Digital / Analog I/O Connectors			
Analog Inputs (Differential)		40	
Mating Connector Part Numbers		35	
Digital and Analog I/O Connector			
Analog Outputs		39	
Digital Inputs		38	
Digital Outputs		36	
Digital and Analog I/O Connector A Pinout		35	
Digital and Analog I/O Connector B Pinout		35	
Digital and Analog I/O Connectors		35	
Digital Input Pins (Digital/Analog I/O B Connector)		38	
Digital Input Specifications		38	
Digital Inputs (Digital and Analog I/O Connector)		38	
Digital Inputs Connected to Current Sinking Devices		38	
Digital Inputs Connected to Current Sourcing Devices		38	
Digital Output Pins (Digital/Analog I/O A Connector)		36	
Digital Output Specifications		36	
Digital Outputs (Digital and Analog I/O Connector)		36	
Digital Outputs Connected in Current Sinking Mode		37	
Digital Outputs Connected in Current Sourcing Mode		37	
Dimensions		19	
Drawing number		23	
Drive and Software Compatibility		21	
	<b>E</b>		
Electrical Noise Suppression Devices		43	
Electrical Specifications		17	
EMC/CE Compliance		28	
Emergency Stop Sense Input		43	
Enclosure		18	
Encoder Input Connector		41	
Mating Connector Part Numbers		41	
Encoder Input Connector A Pinout		41	
Encoder Input Connector B Pinout		41	
Encoder Input Connector Encoder Connections		42	

Encoder Input Connector Specifications	41	HyperWire	29
Encoder Output Connector	31	Cable Part Numbers	29
Encoder Output Connector Mating		Card Part Number	29
Connector Part Numbers	31		
Encoder Output Connector Pinout	31	<b>I</b>	
Encoder Outputs Schematic	31	Input Power Connections	24
Environmental Specifications	20	inspecting cooling vents	48
ESTOP	43	Inspection	48
ESTOP Pins on the Encoder Input Connector	43	Installation and Configuration	23
ESTOP Sense Input Schematic (Encoder Input Connector)	43	Introduction	15
EU 2015/863	7	IP54 Compliant	18
examining parts			
cables	48		
connections	48	<b>L</b>	
examining, dangerous fluids	48	Laser Output Polarity Switch	44
examining, dangerous material	48		
External Power Supply Options	26	<b>M</b>	
		Maintenance	47
<b>F</b>		material, electrically conductive	48
Feature Summary	15	Mating Connector P/N	
Figure		Control Supply Connector	24
Analog Inputs Schematic	40	Digital / Analog I/O Connectors	35
Analog Outputs Schematic	39	Encoder Input Connector	41
Control Board Assembly	49	Encoder Output Connector	31
Control Supply Connections	24	Motor Supply Connector	25
Digital Inputs Connected to Current Sinking Devices	38	PSO Connectors	30
Digital Inputs Connected to Current Sourcing Devices	38	Stage Motor and Feedback Connector	33
Digital Outputs Connected in Current Sinking Mode	37	Mechanical Specifications	18
Digital Outputs Connected in Current Sourcing Mode	37	Minimizing Conducted, Radiated, and System Noise for EMC/CE Compliance	28
Dimensions	19	Minimum Load Resistance	17
Encoder Input Connector Encoder Connections	42	Motor Supply	17
Encoder Outputs Schematic	31	Motor Supply Connections	25
ESTOP Sense Input Schematic	43	Motor Supply Connector	25
Motor Supply Connections	25	Mating Connector Part Numbers	25
Power Board Assembly	50	Motor Supply Wiring Specifications	25
PSO External Sync Input Schematic	32	Mounting and Cooling	18
Third-Party Power Supply Connection	27	Mounting Hardware	18
TM3 Transformer Control and Power Wiring	27	Mounting Orientation	18
fluids, dangerous	48		
Functional Diagram	16	<b>O</b>	
		Operation	20
<b>H</b>		Output Voltage	17
Humidity	20	Overview	15



<b>P</b>		<b>S</b>	
packing list	23	Safety Procedures and Warnings	11
PC Configuration and Operation Information	46	serial number	23
Peak Output Current	17	Specifications	
Pinout		Analog Encoder Input	34
Analog Input Pins (Digital / Analog I/O B Connector)	40	Analog Input (Digital / Analog I/O B Connector)	40
Analog Output Pins (Digital / Analog I/O B Connector)	39	Analog Output (Digital and Analog I/O Connector)	39
Digital and Analog I/O Connector A	35	Control Board Fuses	49
Digital and Analog I/O Connector B	35	Control Supply Connector Wiring	24
Digital Input Pins (Digital/Analog I/O B Connector)	38	Digital Inputs	38
Digital Output Pins (Digital/Analog I/O A Connector)	36	Digital Outputs	36
Encoder Input Connector A	41	Encoder Input Connector	41
Encoder Input Connector B	41	Motor Supply Wiring	25
Encoder Output Connector	31	Power Board Fuses	50
ESTOP Pins on the Encoder Input Connector	43	PSO	30
PSO (Connector A)	30	Unit Weight	18
PSO (Connector B)	30	Stage Motor and Feedback Connector	33
Stage Motor and Feedback Connector	33	Mating Connector Part Numbers	33
Pollution	20	Stage Motor and Feedback Connector Pinout	33
Position Synchronized Output Connector	30	Standard Features	15
Power Board Assembly	50	Sync-Related Commands	45
Power Board Fuse Specifications	50	Sync Port Cables	45
Power Supply Options	26	Sync Ports	45
Preventative Maintenance	48	System part number	23
PSO Connector	30		
PSO Connector A Pinout	30	<b>T</b>	
PSO Connector B Pinout	30	Table of Contents	3
PSO Connectors		Third-Party Power Supply Connection	27
Mating Connector Part Numbers	30	TM3 Transformer Control and Power Wiring	27
PSO External Sync Input Schematic	32		
PSO External Sync Specifications	32	<b>U</b>	
PSO Output Sources	30	Unit Weight	18
PSO Specifications	30	Unpacking the Chassis	23
		Use	20
<b>Q</b>		User Power Supply Output	17
Quick Installation Guide	13		
Quick Start Connections	13	<b>W</b>	
		Warranty and Field Service	51
<b>R</b>			
Revision History	53		

*This page intentionally left blank.*