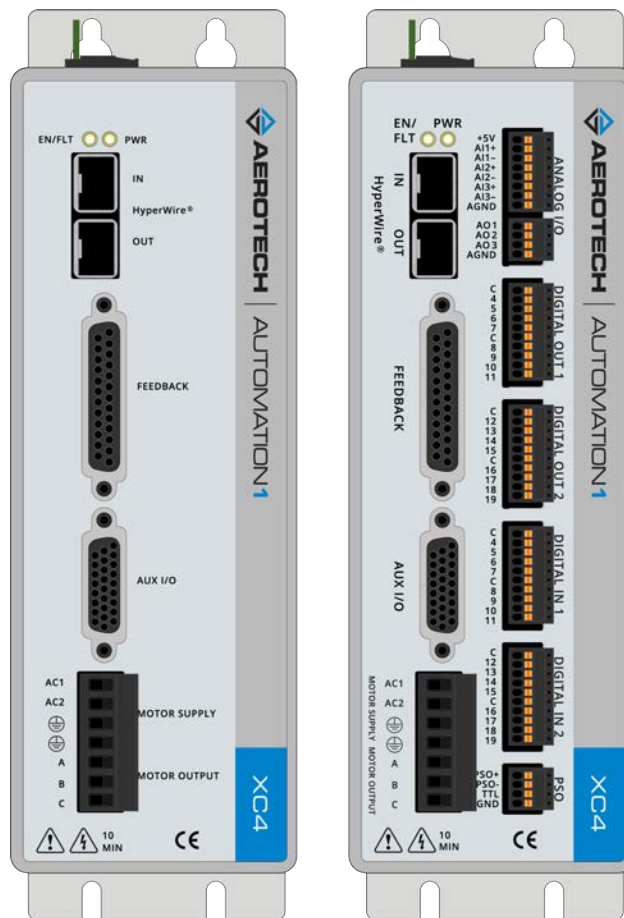


Automation1 XC4 PWM Digital Drive

HARDWARE MANUAL

Revision 2.01



GLOBAL TECHNICAL SUPPORT

Go to the [Global Technical Support Portal](#) for information and support about your Aerotech, Inc. products. The website supplies software, product manuals, Help files, training schedules, and PC-to-PC remote technical support. If necessary, you can complete Product Return (RMA) forms and get information about repairs and spare or replacement parts. To get help immediately, contact a service office or your sales representative. Include your customer order number in your email or have it available before you call.

This manual contains proprietary information and may not be reproduced, disclosed, or used in whole or in part without the express written permission of Aerotech, Inc. Product names mentioned herein are used for identification purposes only and may be trademarks of their respective companies.

Copyright © 2018-2021, Aerotech, Inc., All rights reserved.



Table of Contents

Automation1 XC4 PWM Digital Drive	1
Table of Contents	3
List of Figures	5
List of Tables	7
EU Declaration of Conformity	9
Agency Approvals	11
Safety Procedures and Warnings	13
Installation Overview	15
Chapter 1: Introduction	17
1.1. Electrical Specifications	20
1.1.1. System Power Requirements	21
1.2. Mechanical Specifications	22
1.2.1. Mounting and Cooling	22
1.2.2. Dimensions	23
1.3. Environmental Specifications	25
1.4. Drive and Software Compatibility	26
Chapter 2: Installation and Configuration	27
2.1. Input Power Connections	28
2.1.1. Control Supply Connector	28
2.1.2. Motor Supply Connector	29
2.1.3. Transformer Options	30
2.1.4. Minimizing Noise for EMC/CE Compliance	37
2.2. Motor Power Output Connector	38
2.2.1. Brushless Motor Connections	39
2.2.1.1. Brushless Motor Powered Motor and Feedback Phasing	40
2.2.1.2. Brushless Motor Unpowered Motor and Feedback Phasing	41
2.2.2. DC Brush Motor Connections	42
2.2.2.1. DC Brush Motor Phasing	43
2.2.3. Stepper Motor Connections	44
2.2.3.1. Stepper Motor Phasing	45
2.3. Feedback Connector	46
2.3.1. Primary Encoder Inputs	47
2.3.1.1. Square Wave Encoder	48
2.3.1.2. Absolute Encoder	49
2.3.1.3. Sine Wave Encoder [-MX1 Option]	50
2.3.1.4. Encoder Phasing	52
2.3.2. Hall-Effect Inputs	53
2.3.3. Thermistor Input	54
2.3.4. Encoder Fault Input	55
2.3.5. End of Travel and Home Limit Inputs	56
2.3.5.1. End of Travel and Home Limit Phasing	58
2.3.6. Brake Outputs	59
2.4. Safe Torque Off Input (STO)	60
2.4.1. STO Standards	62
2.4.2. STO Functional Description	63
2.4.3. STO Startup Validation Testing	64
2.4.4. STO Diagnostics	65
2.5. Auxiliary I/O Connector	66
2.5.1. Auxiliary Encoder Inputs	67
2.5.1.1. Square Wave Encoder	68
2.5.1.2. Absolute Encoder	69
2.5.2. Position Synchronized Output (PSO)	70
2.5.3. Digital Outputs	72
2.5.4. Digital Inputs	75
2.5.5. High-Speed Inputs	77
2.5.6. Analog Output 0	78
2.5.7. Analog Input 0 (Differential)	79

2.6. Brake Power Supply Connector	80
2.7. HyperWire Interface	81
2.8. External Shunt Option [-SX1]	82
2.9. Sync Port	84
2.10. System Interconnection	85
2.11. PC Configuration and Operation Information	87
Chapter 3: -EB1 I/O Option Board	89
3.1. Digital Outputs [-EB1]	90
3.2. Digital Inputs [-EB1]	94
3.3. Analog Outputs [-EB1]	97
3.4. Analog Inputs [-EB1]	98
3.5. Position Synchronized Output Interface [-EB1]	99
Chapter 4: Cables and Accessories	101
4.1. Joystick Interface	102
4.2. Handwheel Interface	104
Chapter 5: Maintenance	105
5.1. Preventative Maintenance	106
5.2. Fuse Specifications	107
Appendix A: Warranty and Field Service	109
Appendix B: Revision History	111
Index	113

List of Figures

Figure 1-1:	XC4 Digital Drive	17
Figure 1-2:	Functional Diagram	19
Figure 1-3:	Dimensions	23
Figure 1-4:	Dimensions [-EB1]	24
Figure 2-1:	Control Supply Connections	28
Figure 2-2:	Motor Supply Connections	29
Figure 2-3:	Transformer Examples	30
Figure 2-4:	TV0.3-28-56-ST Transformer Control and Motor Power Wiring (40 VDC Bus)	31
Figure 2-5:	TV0.3-28-56-ST Transformer Control and Motor Power Wiring (80 VDC Bus)	32
Figure 2-6:	TV0.3-28-56-ST Transformer Control and Motor Power Wiring (160 VDC Bus)	33
Figure 2-7:	TV0.3-28 Transformer Control and Motor Power Wiring (40 VDC Bus)	34
Figure 2-8:	TV0.3-56 Transformer Control and Motor Power Wiring (80 VDC Bus)	35
Figure 2-9:	TM3/TM5 Transformer Control and Motor Power Wiring	36
Figure 2-10:	Brushless Motor Configuration	39
Figure 2-11:	Positive Motor Direction	40
Figure 2-12:	Encoder and Hall Signal Diagnostics	40
Figure 2-13:	Brushless Motor Phasing Oscilloscope Example	41
Figure 2-14:	Brushless Motor Phasing Goal	41
Figure 2-15:	DC Brush Motor Configuration	42
Figure 2-16:	Positive Motor Direction	43
Figure 2-17:	Stepper Motor Configuration	44
Figure 2-18:	Positive Motor Direction	45
Figure 2-19:	Square Wave Encoder Schematic (Feedback Connector)	48
Figure 2-20:	Absolute Encoder Schematic (Feedback Connector)	49
Figure 2-21:	Sine Wave Encoder Phasing Reference Diagram	50
Figure 2-22:	Sine Wave Encoder Schematic (Feedback Connector)	51
Figure 2-23:	Encoder Phasing Reference Diagram (Standard)	52
Figure 2-24:	Position Feedback in the Diagnostic Display	52
Figure 2-25:	Hall-Effect Inputs Schematic (Feedback Connector)	53
Figure 2-26:	Thermistor Input Schematic (Feedback Connector)	54
Figure 2-27:	Encoder Fault Input Schematic (Feedback Connector)	55
Figure 2-28:	End of Travel and Home Limit Input Connections	57
Figure 2-29:	End of Travel and Home Limit Input Schematic (Feedback Connector)	57
Figure 2-30:	End of Travel and Home Limit Input Diagnostic Display	58
Figure 2-31:	Brake Connected to the 25-Pin Feedback Connector (Typical)	59
Figure 2-32:	Typical Configuration	61
Figure 2-33:	STO Timing	65
Figure 2-34:	Square Wave Encoder Interface (Aux I/O Connector)	68
Figure 2-35:	Absolute Encoder Schematic (Auxiliary I/O Connector)	69
Figure 2-36:	PSO Interface	71
Figure 2-37:	Digital Output Schematic (Aux I/O Connector)	73
Figure 2-38:	Digital Outputs Connected in Current Sourcing Mode	74
Figure 2-39:	Digital Outputs Connected in Current Sinking Mode	74
Figure 2-40:	Digital Inputs Schematic (Aux I/O Connector)	75
Figure 2-41:	Digital Inputs Connected to Current Sinking Devices	76
Figure 2-42:	Digital Inputs Connected to Current Sourcing Devices	76
Figure 2-43:	High-Speed Inputs	77
Figure 2-44:	Analog Output 0 Schematic	78

Figure 2-45: Analog Input 0 Schematic	79
Figure 2-46: System Wiring Drawing (Best Practice)	85
Figure 2-47: PC-Based Controller System Interconnection (Best Practice)	86
Figure 3-1: XC4 with -EB1 I/O Option Board Connectors	89
Figure 3-2: Digital Outputs Schematic [-EB1]	92
Figure 3-3: Digital Outputs Connected in Current Sourcing Mode [-EB1]	93
Figure 3-4: Digital Outputs Connected in Current Sinking Mode [-EB1]	93
Figure 3-5: Digital Inputs Schematic [-EB1]	95
Figure 3-6: Digital Inputs Connected to Current Sourcing (PNP) Devices [-EB1]	96
Figure 3-7: Digital Inputs Connected to Current Sinking (NPN) Devices [-EB1]	96
Figure 3-8: Analog Output Typical Connection [-EB1]	97
Figure 3-9: Analog Input Typical Connection [-EB1]	98
Figure 3-10: PSO Output Sources Current	100
Figure 3-11: PSO Output Sinks Current	100
Figure 3-12: PSO TTL Outputs Schematic	100
Figure 4-1: Two Axis Joystick Interface (to the Aux I/O of two drives)	102
Figure 4-2: Two Axis Joystick Interface (to the I/O board)	103
Figure 4-3: Handwheel Interconnection to Aux I/O Connector	104
Figure 4-4: Handwheel Interconnection to the Aux I/O through a BBA32 Module	104

List of Tables

Table 1-1: Features and Options	18
Table 1-2: Electrical Specifications	20
Table 1-3: Mounting Specifications	22
Table 1-4: Environmental Specifications	25
Table 1-5: Drive and Software Compatibility	26
Table 2-1: Control Supply Wiring Specifications	28
Table 2-2: Mating Connector Part Numbers for the Control Supply Connector	28
Table 2-3: Motor Supply Connector Wiring Specifications	29
Table 2-4: Mating Connector Part Numbers for the Motor Supply Connector	29
Table 2-5: Nominal Motor Operating Voltages / Required AC Voltages	30
Table 2-6: Transformer Options	30
Table 2-7: Motor Power Output Connector Pinout	38
Table 2-8: Mating Connector Part Numbers for the Motor Power Output Connector	38
Table 2-9: Wire Colors for Aerotech-Supplied Brushless Motor Cables	39
Table 2-10: Hall Signal Diagnostics	40
Table 2-11: Wire Colors for Aerotech-Supplied DC Brush Motor Cables	42
Table 2-12: Wire Colors for Aerotech-Supplied Stepper Motor Cables	44
Table 2-13: Feedback Connector Pinout	46
Table 2-14: Mating Connector Part Numbers for the Feedback Connector	46
Table 2-15: Multiplier Options	47
Table 2-16: Primary Encoder Input Pins on the Feedback Connector	47
Table 2-17: Square Wave Encoder Specifications	48
Table 2-18: Sine Wave Encoder Specifications	50
Table 2-19: Hall-Effect Feedback Pins on the Feedback Connector	53
Table 2-20: Thermistor Input Pin on the Feedback Connector	54
Table 2-21: Encoder Fault Input Pin on the Feedback Connector	55
Table 2-22: End of Travel and Home Limit Pins on the Feedback Connector	56
Table 2-23: Brake Output Pins on the Feedback Connector	59
Table 2-24: Brake Control Specifications	59
Table 2-25: STO Connector Pinout	60
Table 2-26: Mating Connector Part Numbers for the STO Connector	60
Table 2-27: STO Electrical Specifications	61
Table 2-28: STO Standards	62
Table 2-29: STO Standards Data	62
Table 2-30: STO Signal Delay	64
Table 2-31: Motor Function Relative to STO Input State	64
Table 2-32: STO Timing	65
Table 2-33: Auxiliary I/O Connector Pinout	66
Table 2-34: Mating Connector Part Numbers for the Auxiliary I/O Connector	66
Table 2-35: Auxiliary Encoder Pins on the Auxiliary I/O Connector	67
Table 2-36: Square Wave Encoder Specifications	68
Table 2-37: PSO Specifications	70
Table 2-38: PSO Pins on the Auxiliary I/O Connector	70
Table 2-39: Digital Output Specifications	72
Table 2-40: Digital Output Pins on the Auxiliary I/O Connector	72
Table 2-41: Digital Input Specifications	75
Table 2-42: Digital Input Pins on the Auxiliary I/O Connector	75
Table 2-43: High-Speed Input Specifications	77

Table 2-44:	High-Speed Input Pins on the Auxiliary I/O Connector	77
Table 2-45:	Analog Output Specifications	78
Table 2-46:	Analog Output Pins on the Auxiliary I/O Connector	78
Table 2-47:	Analog Input Specifications	79
Table 2-48:	Analog Input Pins on the Auxiliary I/O Connector	79
Table 2-49:	Brake Power Supply Connector Pinout	80
Table 2-50:	Mating Connector Part Numbers for the Brake Power Supply Connector	80
Table 2-51:	HyperWire Card Part Number	81
Table 2-52:	HyperWire Cable Part Numbers	81
Table 2-53:	-SX1 Component Information	82
Table 2-54:	Maximum Additional Storage Energy for a Standard XC4	83
Table 2-55:	Sync-Related Functions	84
Table 2-56:	Sync Port Cables	84
Table 3-1:	Digital Output Specifications [-EB1]	90
Table 3-2:	Digital Output 1 Connector Pinout [-EB1]	91
Table 3-3:	Mating Connector Part Numbers for the Digital Output 1 Connector [-EB1]	91
Table 3-4:	Digital Output 2 Connector Pinout [-EB1]	91
Table 3-5:	Mating Connector Part Numbers for the Digital Output 2 Connector [-EB1]	91
Table 3-6:	Digital Input Specifications [-EB1]	94
Table 3-7:	Digital Input 1 Connector Pinout [-EB1]	94
Table 3-8:	Mating Connector Part Numbers for the Digital Input 1 Connector [-EB1]	94
Table 3-9:	Digital Input 2 Connector Pinout [-EB1]	95
Table 3-10:	Mating Connector Part Numbers for the Digital Input 2 Connector [-EB1]	95
Table 3-11:	Analog Output Specifications [-EB1]	97
Table 3-12:	Analog Output Connector Pinout [-EB1]	97
Table 3-13:	Mating Connector Part Numbers for the Analog Output Connector [-EB1]	97
Table 3-14:	Differential Analog Input Specifications [-EB1]	98
Table 3-15:	Analog Input Connector Pinout [-EB1]	98
Table 3-16:	Mating Connector Part Numbers for the Analog Input Connector [-EB1]	98
Table 3-17:	PSO Specifications [-EB1]	99
Table 3-18:	PSO Interface Connector Pinout [-EB1]	99
Table 3-19:	Mating Connector Part Numbers for the PSO Interface Connector [-EB1]	99
Table 4-1:	Standard Interconnection Cables	101
Table 5-1:	LED Description	105
Table 5-2:	Troubleshooting	105
Table 5-3:	Preventative Maintenance	106
Table 5-4:	Control Board Fuse Specifications	107

EU Declaration of Conformity

Manufacturer Aerotech, Inc.
Address 101 Zeta Drive
 Pittsburgh, PA 15238-2811
 USA
Product XC4
Model/Types All

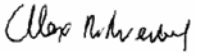
This is to certify that the aforementioned product is in accordance with the applicable requirements of the following Directive(s):

2014/30/EU	Electromagnetic Compatibility (EMC)
2014/35/EU	Low Voltage Directive
2006/42/EC	Machinery Directive
EU 2015/863	Directive, Restricted Substances (RoHS 3)

and has been designed to be in conformity with the applicable requirements of the following Standard(s) when installed and used in accordance with the manufacturer's supplied installation instructions.

EN 61326-1:2013	EMC Requirements for Electrical Equipment
EN 61010-1:2010/A1:2019	Safety Requirements for Electrical Equipment
EN ISO 13849-1:2015	Safety Related Parts of Control Systems

Authorized Representative: Simon Smith, European Director
Address: Aerotech Ltd
 The Old Brick Kiln, Ramsdell, Tadley
 Hampshire RG26 5PR
 UK

Name  / Alex Weibel
Position Engineer Verifying Compliance
Location Pittsburgh, PA
Date 3/24/2021



This page intentionally left blank.

Agency Approvals

Aerotech tested its XC4 drives and found that they obey the standards that follow:

Approval:	CUS NRTL
Approving Agency:	TUV SUD America Inc.
Certificate #:	U8V 068995 0028 Rev. 02
Standards:	CAN/CSA-C22.2 No. 61010-1:2012/U2:2016-04; EN 61010-1:2010/A1:2019; UL 61010-1:2012/R:2016-04
Approval:	Safety Components (STO)
Approving Agency:	TUV SUD
Certificate #:	Z10 068995 0030 Rev. 00
Standards:	IEC 61508-1:2010 (up to SIL 3)

Visit <https://www.tuev-sued.de/product-testing/certificates> to view Aerotech's TÜV SÜD certificates. Type the certificate number listed above in the search bar or type "Aerotech" for a list of all Aerotech certificates.

This page intentionally left blank.

Safety Procedures and Warnings



IMPORTANT: This manual tells you how to carefully and correctly use and operate the XC4 drive.

- Read all parts of this manual before you install or operate the XC4 drive or before you do maintenance to your system.
- To prevent injury to you and damage to the equipment, obey the precautions in this manual.
- All specifications and illustrations are for reference only and were complete and accurate as of the release of this manual. To find the newest information about this product, refer to www.aerotech.com.

If you do not understand the information in this manual, contact Aerotech Global Technical Support.



IMPORTANT: This product has been designed for light industrial manufacturing or laboratory environments. If the product is used in a manner not specified by the manufacturer:

- The protection provided by the equipment could be impaired.
- The life expectancy of the product could be decreased.



DANGER: To decrease the risk of electrical shock, injury, death, and damage to the equipment, obey the precautions that follow.

1. Before you do maintenance to the equipment, disconnect the electrical power.
2. Restrict access to the XC4 when it is connected to a power source.
3. Do not connect or disconnect electrical components, wires, and cables while this product is connected to a power source.
4. Wait at least ten (10) minutes after removing the power supply before doing maintenance or an inspection. Otherwise, there is the danger of electric shock.
5. Supply each operator with the necessary protection from live electrical circuits.
6. Make sure that all components are grounded correctly and that they obey the local electrical safety requirements.
7. Install the necessary precautions to supply safety and protection to the operator.



DANGER: System travel can cause crush, shear, or pinch injuries. Restrict access to all motor and stage parts while your system is connected to a power source.



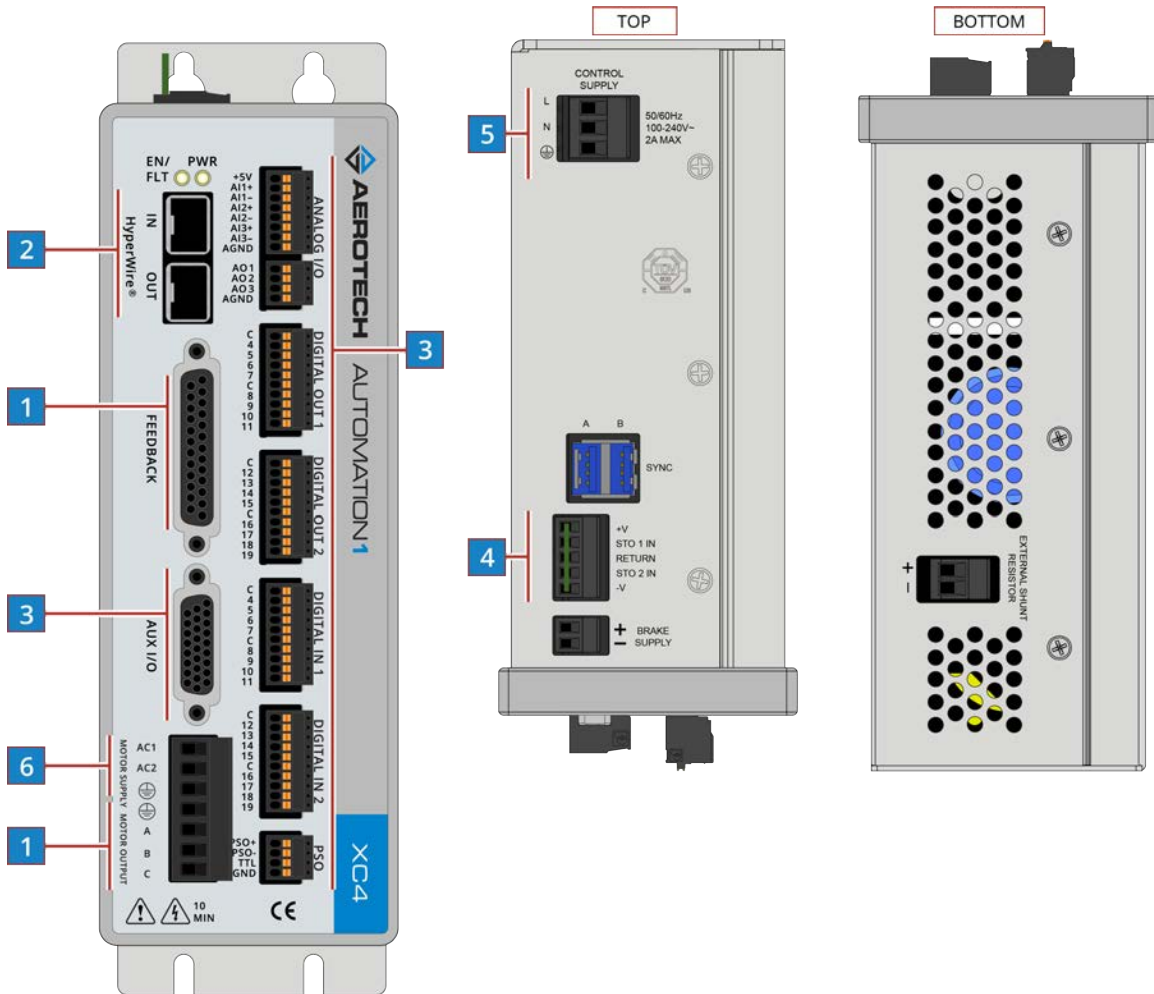
WARNING: To prevent damage to the equipment and decrease the risk of electrical shock and injury, obey the precautions that follow.

1. Make sure that all system cables are correctly attached and positioned.
2. Do not use the cables or the connectors to lift or move this product.
3. Use this product only in environments and operating conditions that are approved in this manual.
4. Only trained operators should operate this equipment.

This page intentionally left blank.

Installation Overview

This image shows the order in which to make connections and settings that are typical to the XC4. If a custom interconnect drawing was supplied with your system, that drawing is on your Storage Device and shows as a line item on your Sales Order in the Integration section.



1	Connect the motor to the amplifier Motor Output connector.	Section 2.2.
1	Connect the motor to the amplifier Feedback connector.	Section 2.3.
2	Connect a PC HyperWire port to the HyperWire In port.	Section 2.7.
3	Connect additional I/O as required by your application (if you purchased the I/O option).	Section 2.5./ Chapter 3
4	Connect the Safe Torque Off (STO).	Section 2.4.
5	Connect the power supply to the Control Supply connector.	Section 2.1.1.
6	Connect the motor power to the Motor Supply connector.	Section 2.1.2.

Figure 1: Installation Connection Overview

This page intentionally left blank.

Chapter 1: Introduction

The XC4 is a high performance digital drive based on the HyperWire communication protocol. The drive provides deterministic behavior, auto-identification, is fully software configurable. A double precision floating point DSP controls the digital PID and current loops in the XC4.

The XC4 offers standard Safe Torque Off (STO) inputs and optional Position Synchronized Output (PSO) outputs. The XC4 is offered with an optional encoder interpolation feature (-MX1), an auxiliary encoder input for dual loop control, dedicated analog and digital I/O (expandable with the -EB1 option), and separate power connections for motor and control supply voltages.

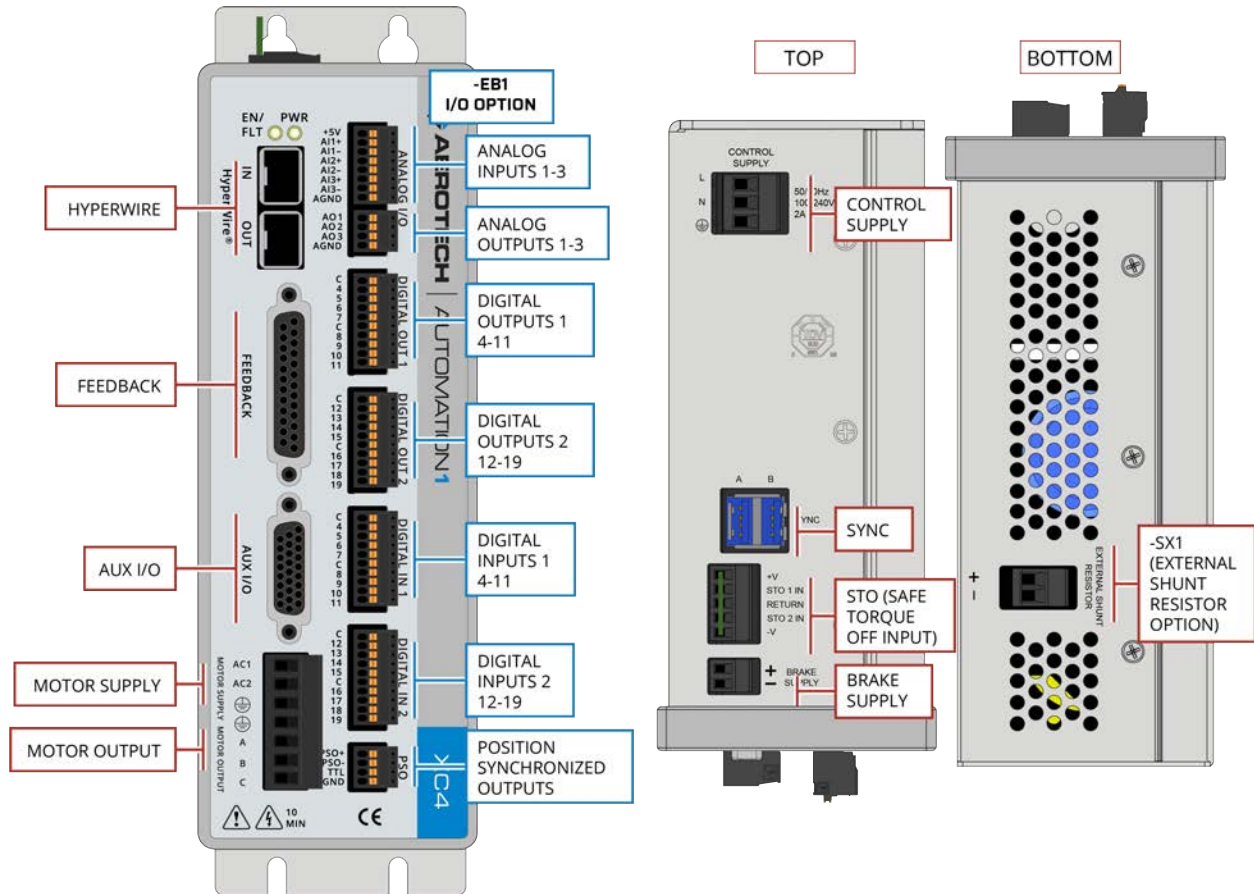


Figure 1-1: XC4 Digital Drive

Table 1-1: Features and Options

Standard Features		
•	100-240 VAC control supply inputs	Section 2.1.1.
•	0-240 VAC motor supply inputs (producing 340 VDC)	Section 2.1.2.
•	Line driver square wave quadrature encoder input for position and velocity feedback	Section 2.3.1.
•	Absolute Encoder support on the Feedback connector	Section 2.3.1.2.
•	One fail-safe brake output	Section 2.3.6.
•	Two STO sense inputs	Section 2.4.
•	Line driver square wave auxiliary quadrature encoder input or output for PSO	Section 2.5.1.
•	Absolute Encoder support on the Auxiliary I/O connector	Section 2.5.1.2.
•	Four digital user outputs	Section 2.5.3.
•	Six digital user inputs	
▪	Four Digital Inputs	Section 2.5.4.
▪	Two High-Speed Inputs	Section 2.5.5.
•	One 16-bit analog output (± 10 V)	Section 2.5.6.
•	One 16-bit differential analog input (± 10 V)	Section 2.5.7.
Options		
Peak Current		Section 1.1.
-10	10 A Peak, 5 A Continuous Current	
-20	20 A Peak, 10 A Continuous Current	
-30	30 A Peak, 10 A Continuous Current	
Expansion Board		Chapter 3
-EB0	No expansion board	
-EB1	I/O expansion board <ul style="list-style-type: none"> • Three 16-bit analog outputs (± 10 V) • Three 16-bit differential analog inputs (± 10 V) • 16 digital logic inputs (5 - 24 VDC), may be connected to current sourcing or sinking devices • 16 digital logic outputs (5 - 24 VDC), user defined as current sourcing or sinking • Digital logic laser firing (PSO) output 	
Multiplier		Section 2.3.1.3.
-MX0	No encoder multiplier	
-MX1	Interpolation circuit allowing for analog sine wave input on the primary encoder channel with an interpolation factor of 16,384.	
PSO		Section 2.5.2.
-PSO1	One-axis PSO firing (includes One-axis Part-Speed PSO)	
External Shunt		Section 2.8.
-SX0	No connector for the External Shunt	
-SX1	Connection provided for an external shunt resistor network	
Version		
-DEFAULT	Firmware Matches Software Line	
-LEGACY	Legacy Firmware Version X.XX.XXX	

The block diagram that follows shows a summary of the connector signals.

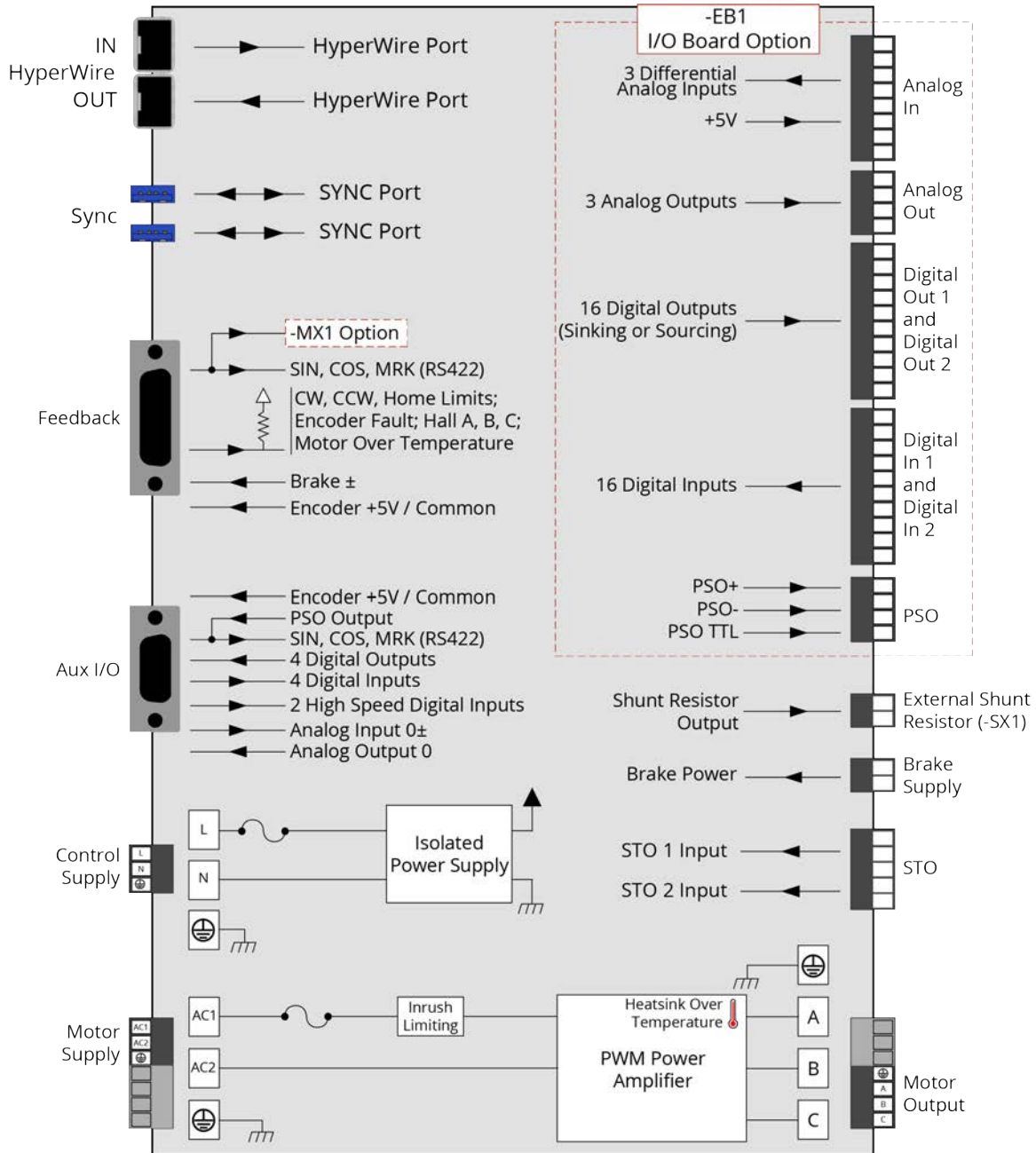


Figure 1-2: Functional Diagram

1.1. Electrical Specifications

Table 1-2: Electrical Specifications

Description		-10 Option	-20 Option	-30 Option
Motor Supply	Input Voltage	0-240 VAC		
	Input Frequency	50-60 Hz		
	Inrush Current	34 A _{pk} @ 240 V		
	Maximum Continuous Input Current	5 A _{rms}	10 A _{rms}	10 A _{rms}
	Input Current	Refer to Section 1.1.1. System Power Requirements		
Control Supply	Input Voltage	100-240 VAC		
	Input Frequency	50-60 Hz		
	Inrush Current	68 A _{pk} @ 240 V		
	Input Power	10 W		
Output Voltage ⁽¹⁾		340 VDC		
Peak Output Current (1 second) ⁽³⁾		10 A	20 A	30 A
Continuous Output Current ⁽³⁾		5 A	10 A	10 A
Power Amplifier Bandwidth		2500 Hz maximum (software selectable)		
Power Amplifier Efficiency		85% - 95% ⁽²⁾		
PWM Switching Frequency		20 kHz		
Minimum Load Inductance		0.1 mH @ 160 VDC (1 mH @ 320 VDC)		
User Power Supply Output		5 VDC (@ 500 mA)		
Modes of Operation		Brushless; Brush; Stepper		
Protective Features		Output short circuit; Peak over current; DC bus over voltage; RMS over current; Over temperature; Control power supply under voltage; Power stage bias supply under voltage		
Isolation		Optical and transformer isolation between control and power stages.		
(1) AC input voltage and load dependent.				
(2) Dependent on total output power: efficiency increases with increasing output power.				
(3) Current is measured as the peak amplitude in any motor phase				

1.1.1. System Power Requirements

The following equations can be used to determine total system power requirements. The actual power required from the mains supply will be the combination of actual motor power (work), motor resistance losses, and efficiency losses in the power electronics or power transformer.

Use an EfficiencyFactor of approximately 90% in the following equations.

Brushless Motor

Output Power

Rotary Motors Power Output [W] = Torque [N·m] * Angular velocity[rad/sec]

Linear Motors Power Output [W] = Force [N] * Linear velocity[m/sec]

Rotary or Linear Motors Power Output [W] = Bemf [V] * I(rms) * 3

Power Loss = $3 * I(\text{rms})^2 * R(\text{line-line})/2$

Power Input = (Power Output + Power Loss) / EfficiencyFactor

DC Brush Motor

Power Output [W] = Torque [N·m] * Angular velocity[rad/sec]

Power Loss = $I(\text{rms})^2 * R$

Power Input = (Pout + Ploss) / EfficiencyFactor

1.2. Mechanical Specifications

1.2.1. Mounting and Cooling

Install the drive in an IP54 compliant enclosure to comply with safety standards. Make sure that there is sufficient clearance surrounding the drive for free airflow and for the cables and connections.

Table 1-3: Mounting Specifications

		XC4
Customer-Supplied Enclosure		IP54 Compliant
Weight		~2.36 kg
Mounting Hardware		M4 [#8] screws (four locations, not included)
Mounting Orientation		Vertical (typical)
Dimensions		Refer to Section 1.2.2. Dimensions
Minimum Clearance	Airflow	~25 mm
	Connectors	~100 mm
Operating Temperature		Refer to Section 1.3. Environmental Specifications

1.2.2. Dimensions

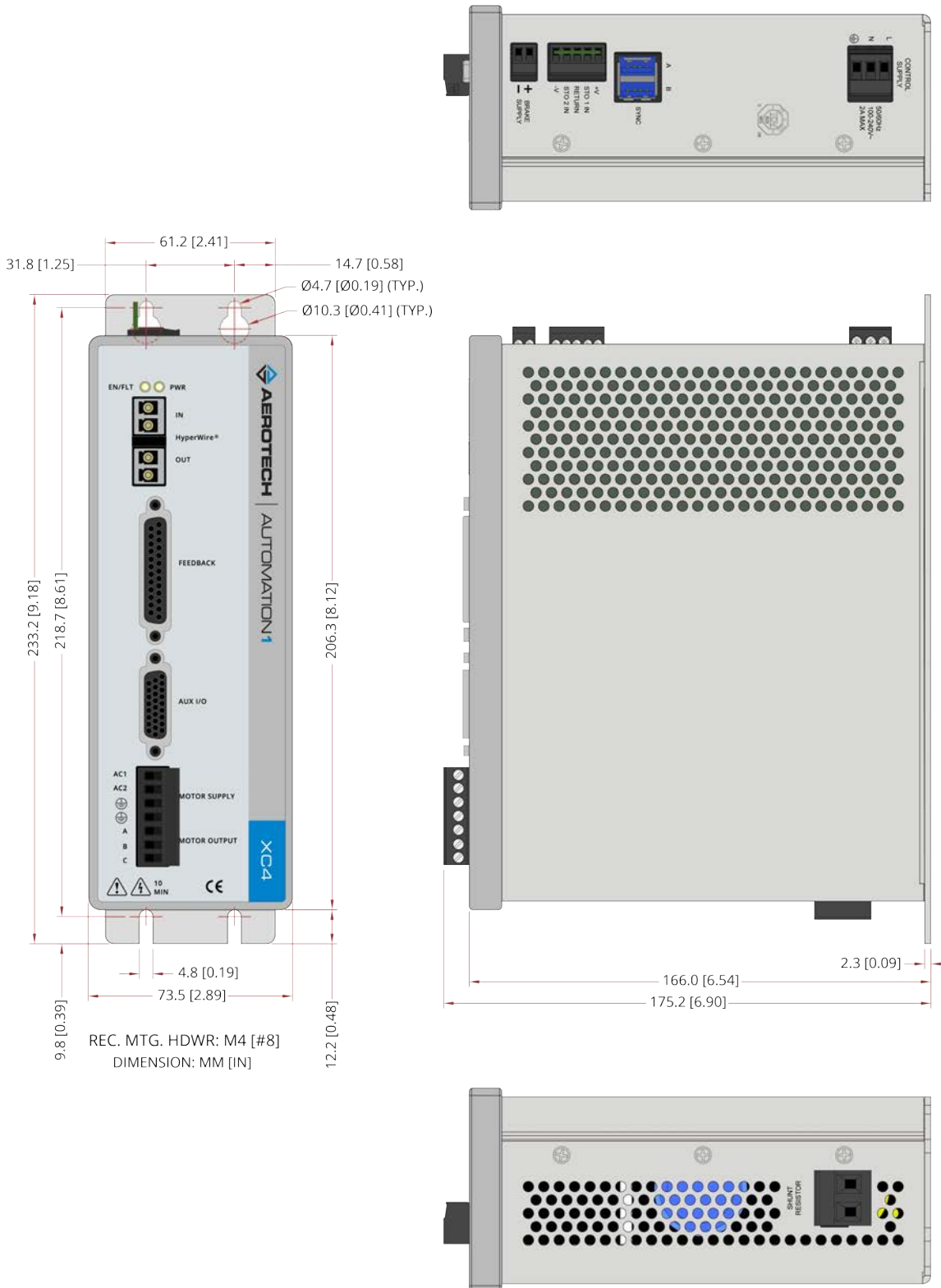


Figure 1-3: Dimensions

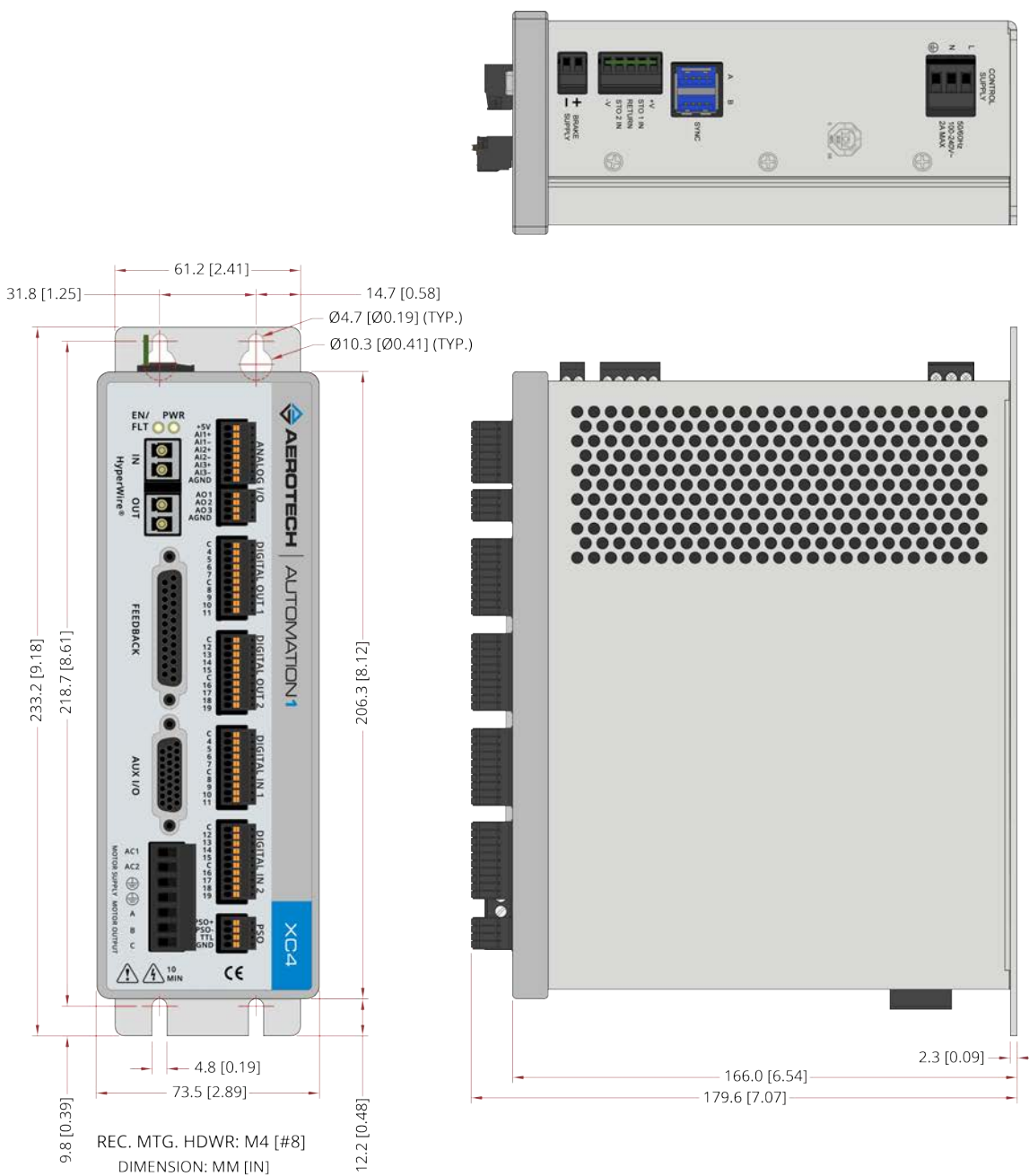


Figure 1-4: Dimensions [-EB1]

1.3. Environmental Specifications

Table 1-4: Environmental Specifications

Ambient Temperature	Operating: 0° to 40°C (32° to 104° F)
	Storage: -30° to 85°C (-22° to 185° F)
Humidity Non-condensing	The maximum relative humidity is 80% for temperatures that are less than 31°C and decreases linearly to 50% relative humidity at 40°C.
Operating Altitude	0 m to 2,000 m (0 ft to 6,562 ft) above sea level. If you must operate this product above 2,000 m or below sea level, contact Aerotech, Inc.
Pollution	Pollution Degree 2 Typically only nonconductive pollution occurs.
Operation	Use only indoors

1.4. Drive and Software Compatibility

This table shows the available drives and which version of the software first supported each drive. In the **Last Software Version** column, drives that show a specific version number are not supported after that version.

Table 1-5: Drive and Software Compatibility

Drive Type	Software	First Software Version	Last Software Version
Automation1 XC4	Automation1	1.0	Current
	A3200	6.04	Current

Chapter 2: Installation and Configuration

Unpacking the Chassis



IMPORTANT: All electronic equipment and instrumentation is wrapped in antistatic material and packaged with desiccant. Ensure that the antistatic material is not damaged during unpacking.

Inspect the container of the XC4 for any evidence of shipping damage. If any damage exists, notify the shipping carrier immediately.

Remove the packing list from the XC4 container. Make sure that all the items specified on the packing list are contained within the package.

The documentation for the XC4 is on the included installation device. The documents include manuals, interconnection drawings, and other documentation pertaining to the system. Save this information for future reference. Additional information about the system is provided on the Serial and Power labels that are placed on the XC4 chassis.

The system serial number label contains important information such as the:

- Customer order number (please provide this number when requesting product support)
- Drawing number
- System part number

2.1. Input Power Connections

The XC4 has two AC input power connectors. One connector is for control power and the other connector is for motor power. For a full list of electrical specifications, refer to [Section 1.1](#). Refer to [Section 2.10](#) for a System Interconnection Drawing.

2.1.1. Control Supply Connector

The Control Supply input supplies power to the communications and logic circuitry of the XC4. The **L** input is connected to an internal fuse. Refer to [Table 5-4](#) for the internal fuse value and part number. The **N** input is not connected to an internal fuse. An external fuse will be required if **N** is not connected to Neutral.

The Control Supply contains an internal filter but you could be required to add an external filter for CE compliance. Install the external filter as close as possible to the XC4. Use a Schaffner FN2080 filter, an Aerotech UFM-ST noise filter module, or equivalent device.



IMPORTANT: Refer to local electrical safety requirements to correctly size external system wires.

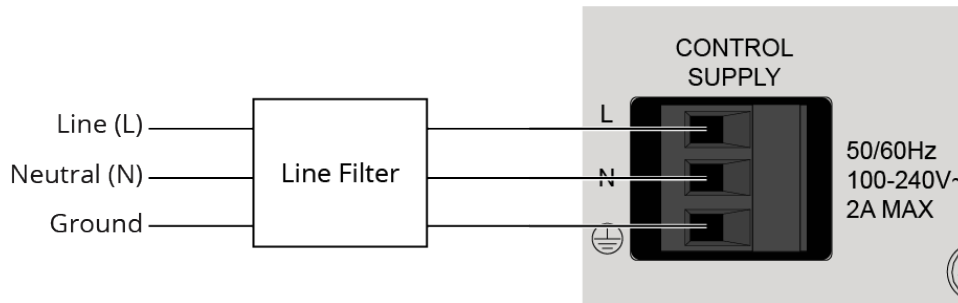


Figure 2-1: Control Supply Connections

Table 2-1: Control Supply Wiring Specifications

Pin	Description	Recommended Wire Size
L	Line (L): 100-240 VAC Control Power Input	0.8 mm ² (#18 AWG)
N	Neutral (N) or 100-240 VAC Control Power Input with external fuse	0.8 mm ² (#18 AWG)
	Protective Ground	0.8 mm ² (#18 AWG)

Table 2-2: Mating Connector Part Numbers for the Control Supply Connector

Type	Aerotech P/N	Third Party P/N	Screw Torque: N·m	Wire Size: mm ² [AWG]
3-Pin Terminal Block	ECK00213	Phoenix 1754465	0.5 - 0.6	3.3 - 0.516 [12-30]

2.1.2. Motor Supply Connector

Motor power is applied to the **AC1** and **AC2** terminals of the XC4 Motor Supply connector. The XC410 **AC1** input is internally connected to a 5 A fuse. The XC420/30 **AC1** input is internally connected to a 10 A fuse. Refer to [Table 5-4](#) for the internal fuse part numbers. The **AC2** input is not internally fused. An external fuse is required if **AC2** is not connected to Neutral.



IMPORTANT: Before you operate the XC4, install a ground connection for your safety and to prevent damage to the equipment.

For CE compliance, Aerotech recommends that you use an AC line filter. Connect the filter as close as possible to the drive. For more information about the AC line filter, refer to [Section 2.1.4](#).



IMPORTANT: Refer to local electrical safety requirements to correctly size external system wires.

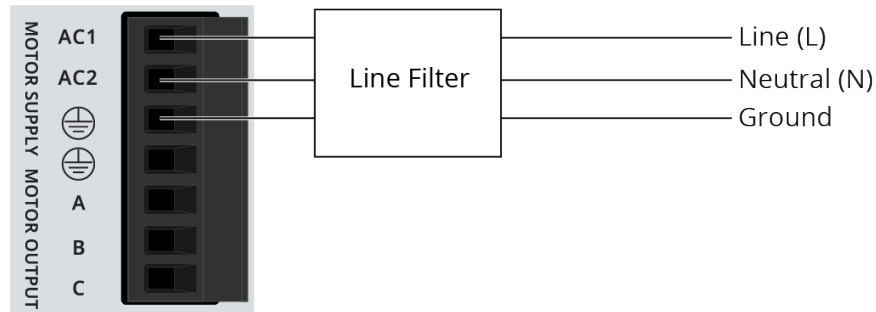


Figure 2-2: Motor Supply Connections

Table 2-3: Motor Supply Connector Wiring Specifications

Pin	Description	Recommended Wire Size
AC1	0-240 VAC Motor Power Input	0.5 mm ² (#20 AWG)
AC2	Neutral (N) or 240 VAC Motor Power Input with external fuse	0.5 mm ² (#20 AWG)
	Protective Ground	0.5 mm ² (#20 AWG)

Table 2-4: Mating Connector Part Numbers for the Motor Supply Connector

Type	Aerotech P/N	Third Part P/N	Screw Torque: Nm	Wire Size: mm ² [AWG]
7-Pin Terminal Block	ECK02387	Phoenix 1756353	0.5 - 0.6	3.3 - 0.0516 [12-30]

2.1.3. Transformer Options

You can connect an external isolation transformer to the Motor Supply AC Input to reduce the operating voltage of the motor. Using a transformer can also reduce electrical noise.

Table 2-5: Nominal Motor Operating Voltages / Required AC Voltages

AC Voltage	DC Voltage
28	40
56	80
115	160
230	320

Table 2-6: Transformer Options

Transformer	Description
TV0.3-28-56-ST	Generate 28 or 56 VAC from 115 VAC or 230 VAC input source voltage. When rectified by the drive, it produces a 40 or 80 VDC power bus.
TM3	Power up to 4 drives, providing 300 watts of power
TM5	Power up to 4 drives providing 500 watts of power
TV0.3-28	Generate 28 VAC from 115 VAC or 230 VAC input source voltage. When rectified by the drive, it produces a 40 VDC power bus.
TV0.3-56	Generate 56 VAC from 115 VAC or 230 VAC input source voltage. When rectified by the drive, it produces an 80 VDC power bus.
TV1.5, TV2.5, or TV5	1.5 kVA, 2.5 kVA, or 5 kVA isolation transformer; 115/230 VAC input; 28, 43, 56, 70, 115 VAC output

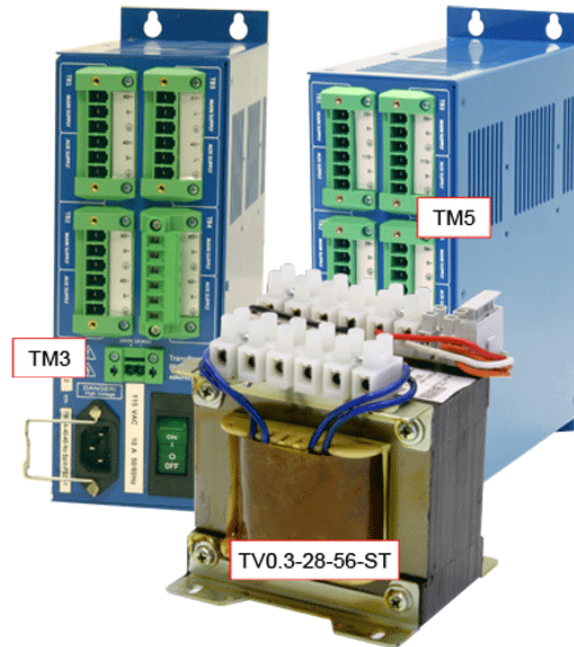


Figure 2-3: Transformer Examples

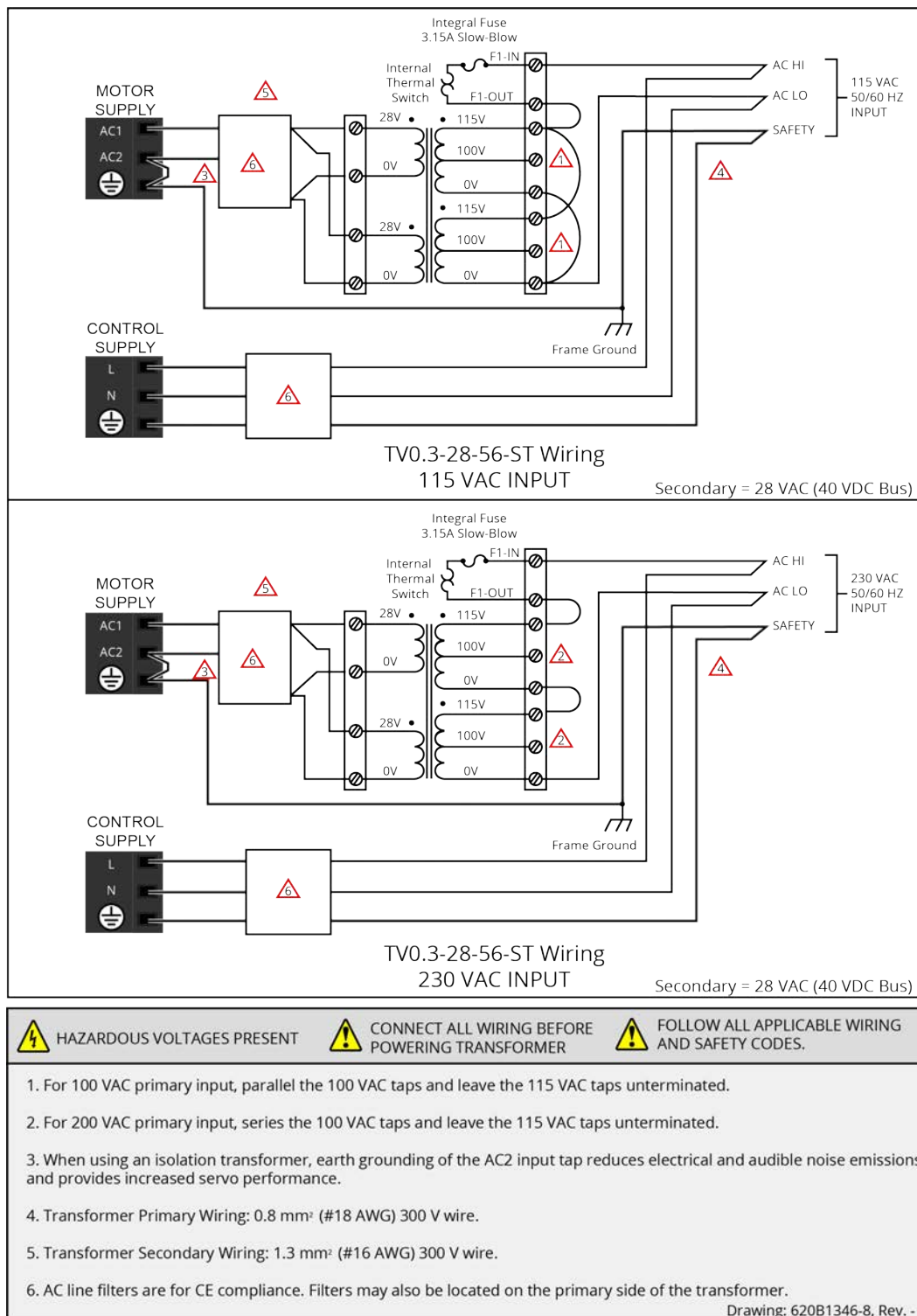


Figure 2-4: TV0.3-28-56-ST Transformer Control and Motor Power Wiring (40 VDC Bus)

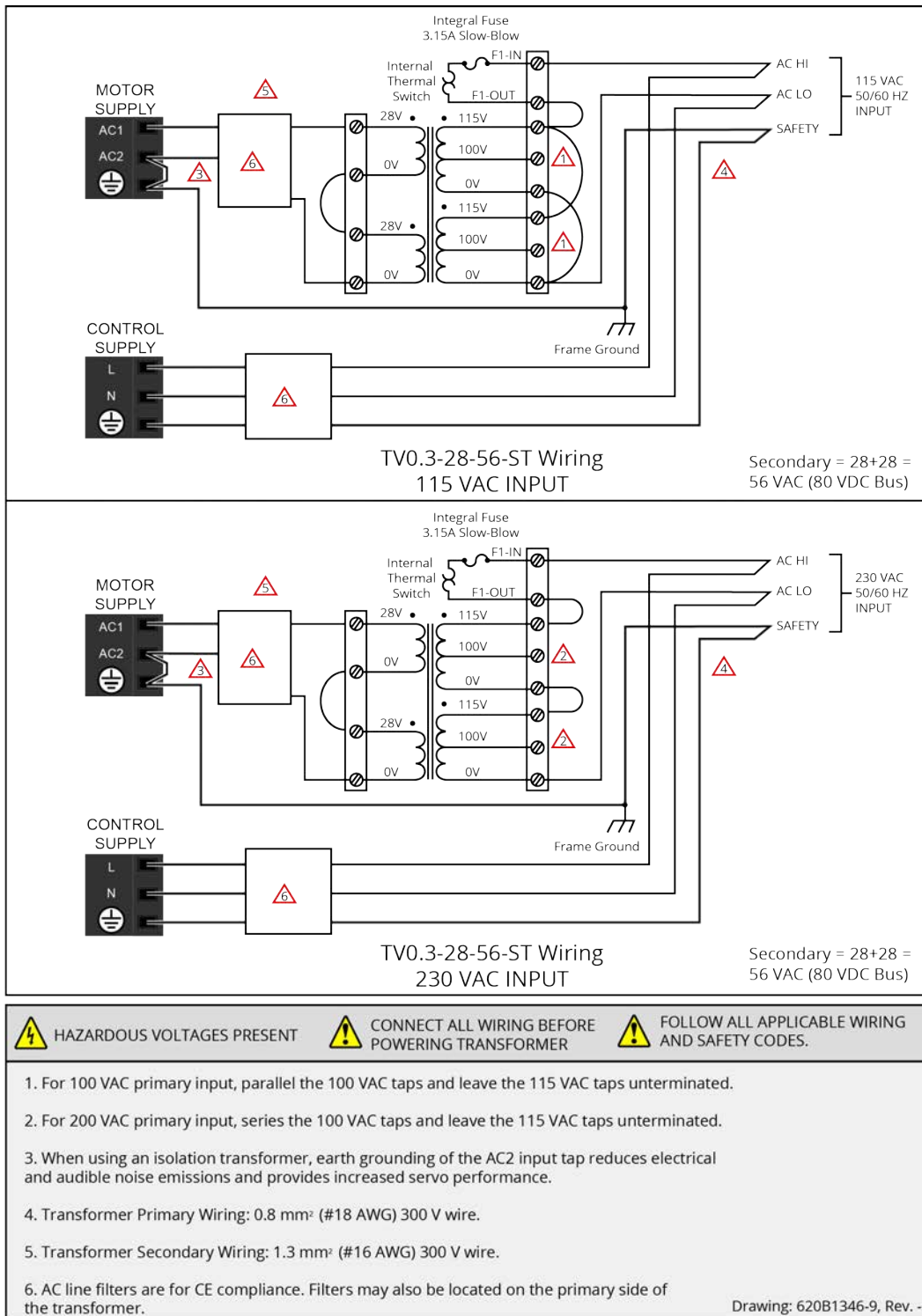


Figure 2-5: TV0.3-28-56-ST Transformer Control and Motor Power Wiring (80 VDC Bus)

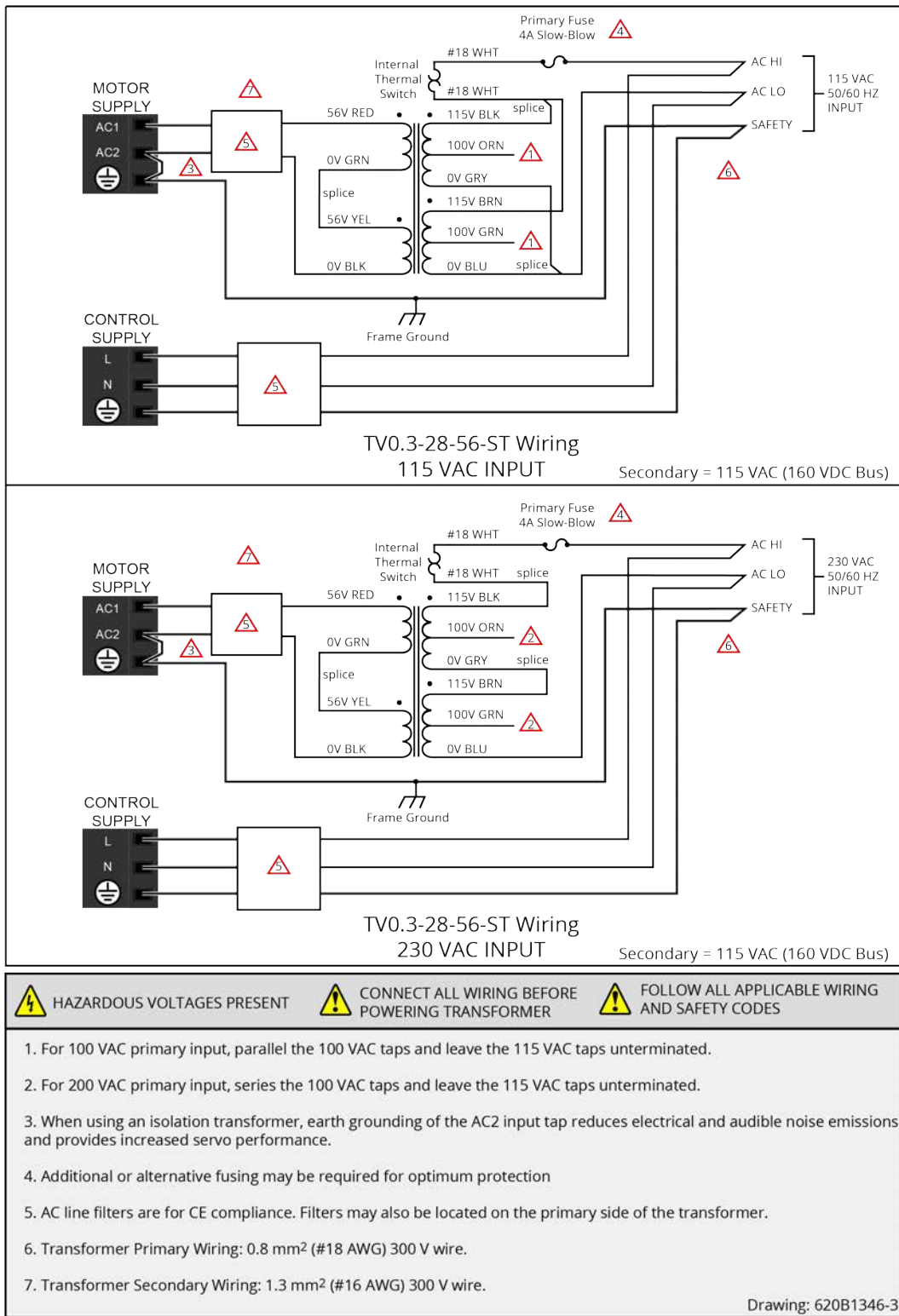


Figure 2-6: TV0.3-28-56-ST Transformer Control and Motor Power Wiring (160 VDC Bus)

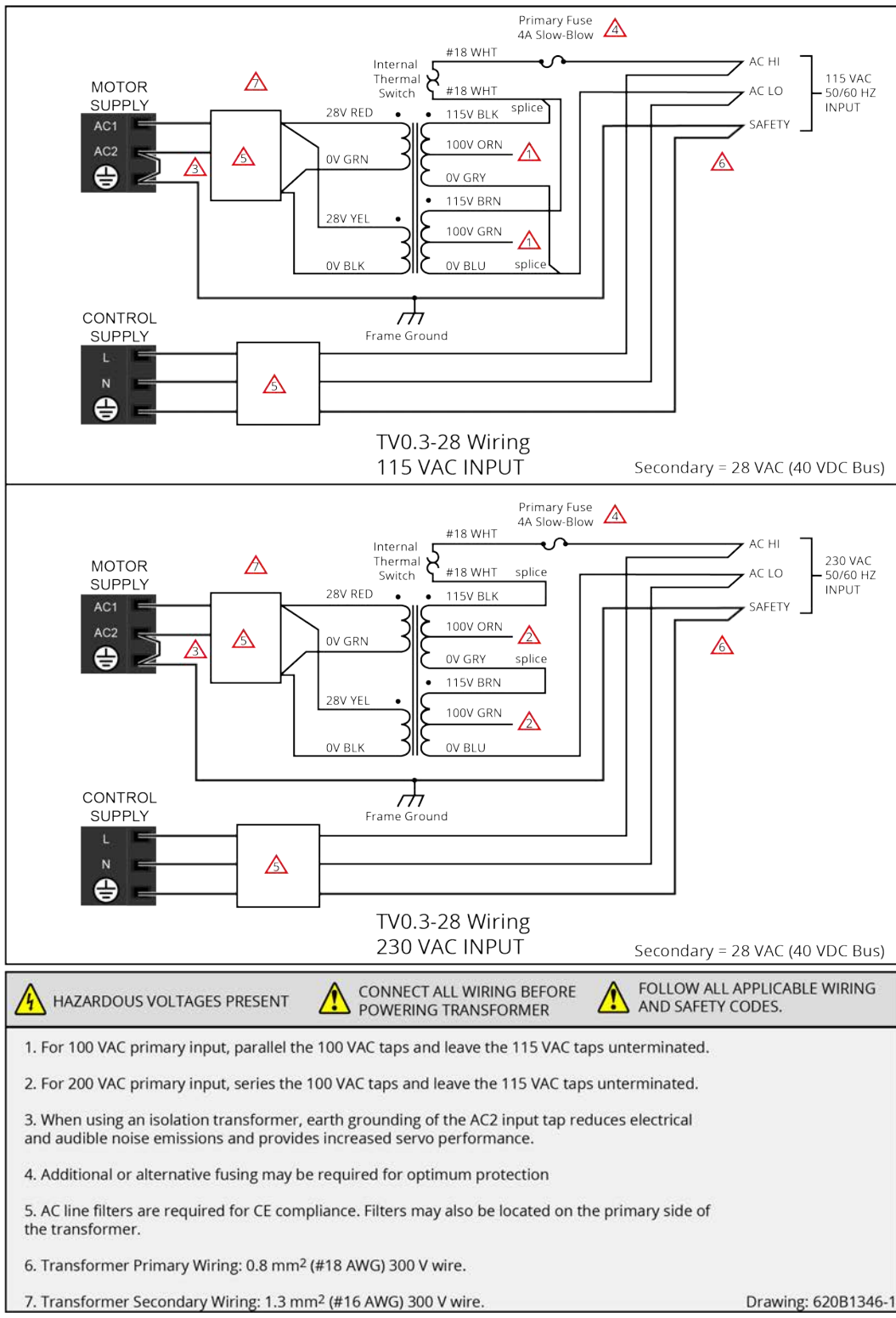


Figure 2-7: TV0.3-28 Transformer Control and Motor Power Wiring (40 VDC Bus)

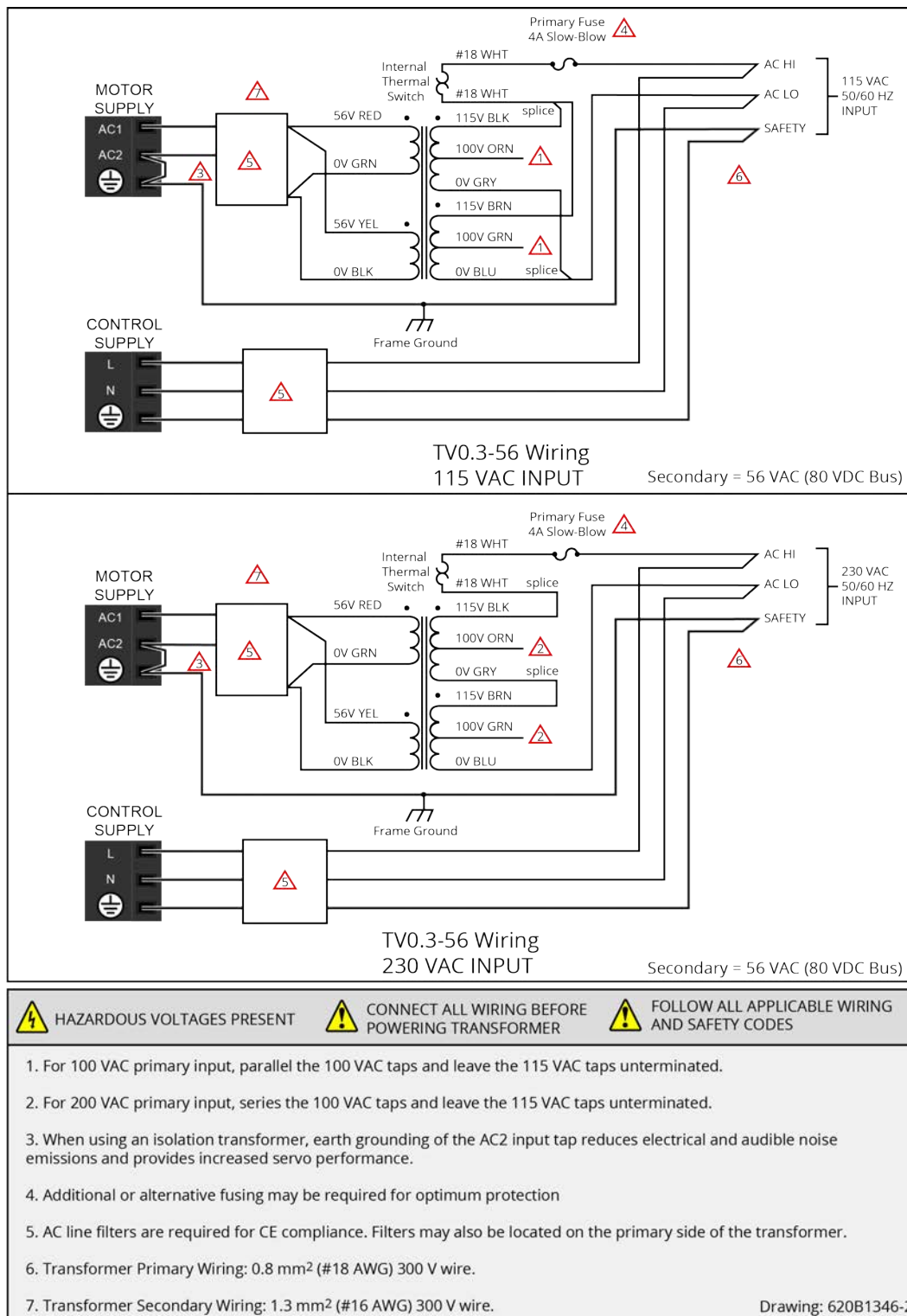


Figure 2-8: TV0.3-56 Transformer Control and Motor Power Wiring (80 VDC Bus)

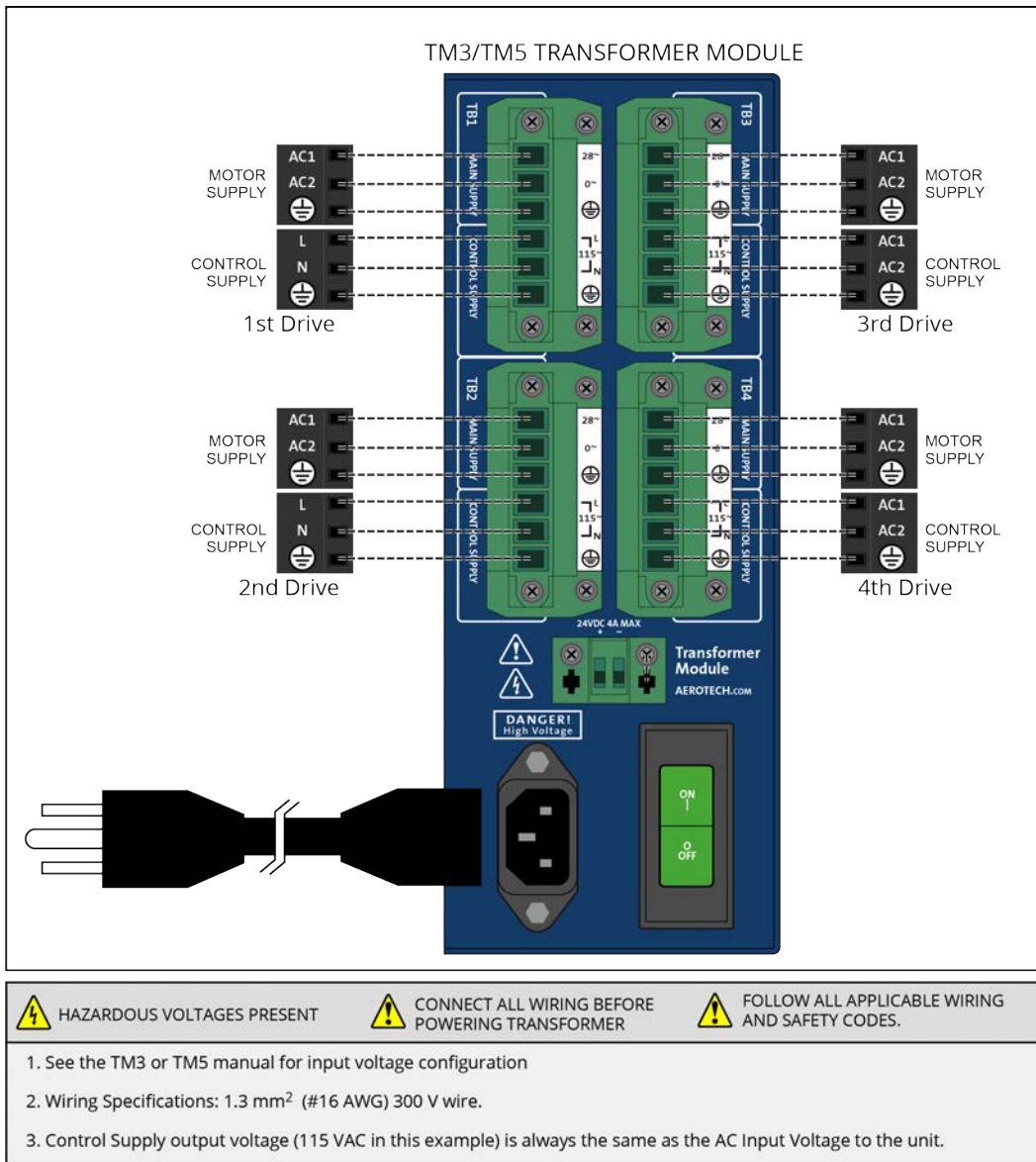


Figure 2-9: TM3/TM5 Transformer Control and Motor Power Wiring

2.1.4. Minimizing Noise for EMC/CE Compliance



IMPORTANT: The XC4 is a component designed to be integrated with other electronics. EMC testing must be conducted on the final product configuration.

To reduce electrical noise, observe the following motor feedback and input power wiring techniques.

1. Use shielded cable for motor and feedback connectors. Connect the shield to the backshell at each end of the cable.
2. Separate motor and power wiring from encoder and I/O wiring.
3. Mount drives, power supplies, and filter components on a conductive panel. Mount line filters close to the drive to keep the wire length between the drive and filter to a minimum. Use a line filter, such as Aerotech's UFM-ST, on the Motor Supply and Control Supply AC inputs.
4. Use the lowest motor voltage required by the application to reduce radiated emission.
5. Use an isolation transformer with grounded secondary to keep the effects of high frequency PWM amplifier currents to a minimum.
6. Use a separate wire for each ground connection to the drive. Use the shortest possible wire length.

The following additional changes could be required for EMC compliance and are recommended during initial EMC system evaluation.

1. Add a clamp-on ferrite to the feedback cable close to the drive.
[Aerotech PN ECZ02348, Fair-rite PN 0446167281]
2. Add a clamp-on ferrite to the Motor Supply and Control Supply wires, including the ground wire, close to the drive.
[Aerotech PN ECZ02347, Fair-rite PN 0446164281]
3. Add a ferrite core to the UFM-ST AC input wires. Wrap the AC wires and ground wire around the core one time.
[Ferrite core: Aerotech PN ECZ02350, Fair-rite PN 2646102002]
4. Add a ferrite core to the motor phase and ground wires close to the drive. Wrap all four wires around the ferrite core once. Remove ferrite beads from Aerotech supplied cables if installed.
[Ferrite core: Aerotech PN ECZ02349, Fair-rite PN 2646626402]
5. Install a motor filter module MFM10-1 close to the drive. The ferrite core that you added to the motor phase and ground wires should be located between the drive and the MFM10-1.

2.2. Motor Power Output Connector



DANGER: Before you do maintenance to the equipment, disconnect the electrical power. Wait at least ten (10) minutes after removing the power supply before doing maintenance or an inspection. Otherwise, there is the danger of electric shock.

The XC4 can be used to drive the following motor types:

- Brushless (refer to [Section 2.2.1.](#))
- DC Brush (refer to [Section 2.2.2.](#))
- Stepper (refer to [Section 2.2.3.](#))

For a complete list of electrical specifications, refer to [Section 1.1.](#)



IMPORTANT: Refer to local electrical safety requirements to correctly size external system wires.

The 7-pin terminal block style motor output connector is located on the front panel. The pinout for this connector is shown in [Table 2-7.](#)

Table 2-7: Motor Power Output Connector Pinout


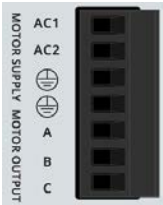
Pin	Description	Recommended Wire Size	Connector
	Earth Ground to Motor	1.3 mm ² (#16 AWG)	
A	Brushless Phase A Motor Lead DC Brush + Stepper	1.3 mm ² (#16 AWG)	
B	Brushless Phase B Motor Lead Stepper	1.3 mm ² (#16 AWG)	
C	Brushless Phase C Motor Lead DC Brush - Stepper Return	1.3 mm ² (#16 AWG)	

Table 2-8: Mating Connector Part Numbers for the Motor Power Output Connector

Type	Aerotech P/N	Third Part P/N	Screw Torque: Nm	Wire Size: mm ² [AWG]
7-Pin Terminal Block	ECK02387	Phoenix 1756353	0.5 - 0.6	3.3 - 0.0516 [12-30]

2.2.1. Brushless Motor Connections

The configuration shown in [Figure 2-10](#) is an example of a typical brushless motor connection.

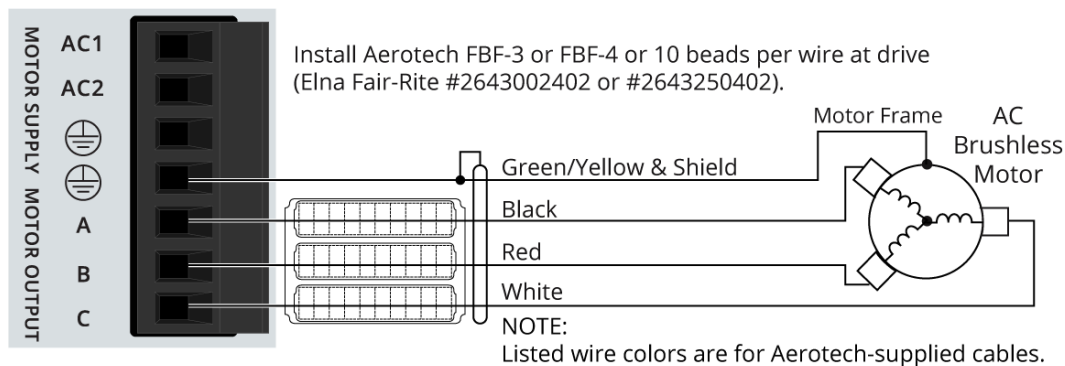


Figure 2-10: Brushless Motor Configuration

Table 2-9: Wire Colors for Aerotech-Supplied Brushless Motor Cables

Pin	Wire Color Set 1 ⁽¹⁾	Wire Color Set 2	Wire Color Set 3	Wire Color Set 4
⊕	Green/Yellow & Shield ⁽²⁾	Green/Yellow & Shield	Green/Yellow & Shield	Green/Yellow & Shield
A	Black	Blue & Yellow	Black #1	Black & Brown
B	Red	Red & Orange	Black #2	Red & Orange
C	White	White & Brown	Black #3	Violet & Blue

(1) Wire Color Set #1 is the wire set typically used by Aerotech.
(2) "&" indicates two wires (Red & Orange); "/" indicates a single wire (Green/White).

Brushless motors are commutated electronically by the controller. The use of Hall effect devices for commutation is recommended.

The controller requires that the Back-EMF of each motor phase be aligned with the corresponding Hall-effect signal. To ensure proper alignment, motor, Hall, and encoder connections should be verified using one of the following methods: *powered*, through the use of a test program; or *unpowered* using an oscilloscope. Both methods will identify the A, B, and C Hall/motor lead sets and indicate the correct connections to the controller. Refer to [Section 2.2.1.1](#) for powered motor phasing or [Section 2.2.1.2](#) for unpowered motor and feedback phasing.

For Aerotech-supplied systems, the motor, encoder and Hall sensors are correctly configured and connection adjustments are not necessary.

A motor filter module can be installed between the drive and the motor to reduce the effects on PWM generated noise currents.

2.2.1.1. Brushless Motor Powered Motor and Feedback Phasing

Observe the state of the encoder and Hall-effect device signals in the Diagnostics section of the Status Utility.

Table 2-10: Hall Signal Diagnostics

Hall-Signal Status	Definition
--	0 V or logic low
ON	5 V or logic high

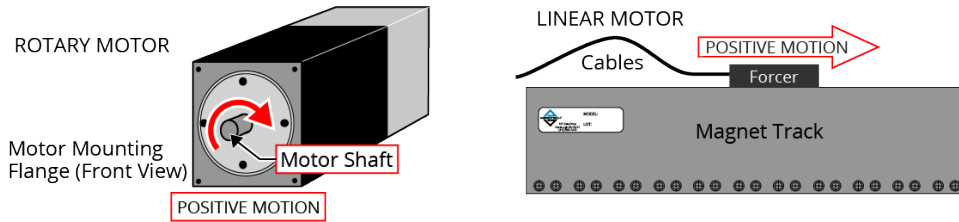


Figure 2-11: Positive Motor Direction

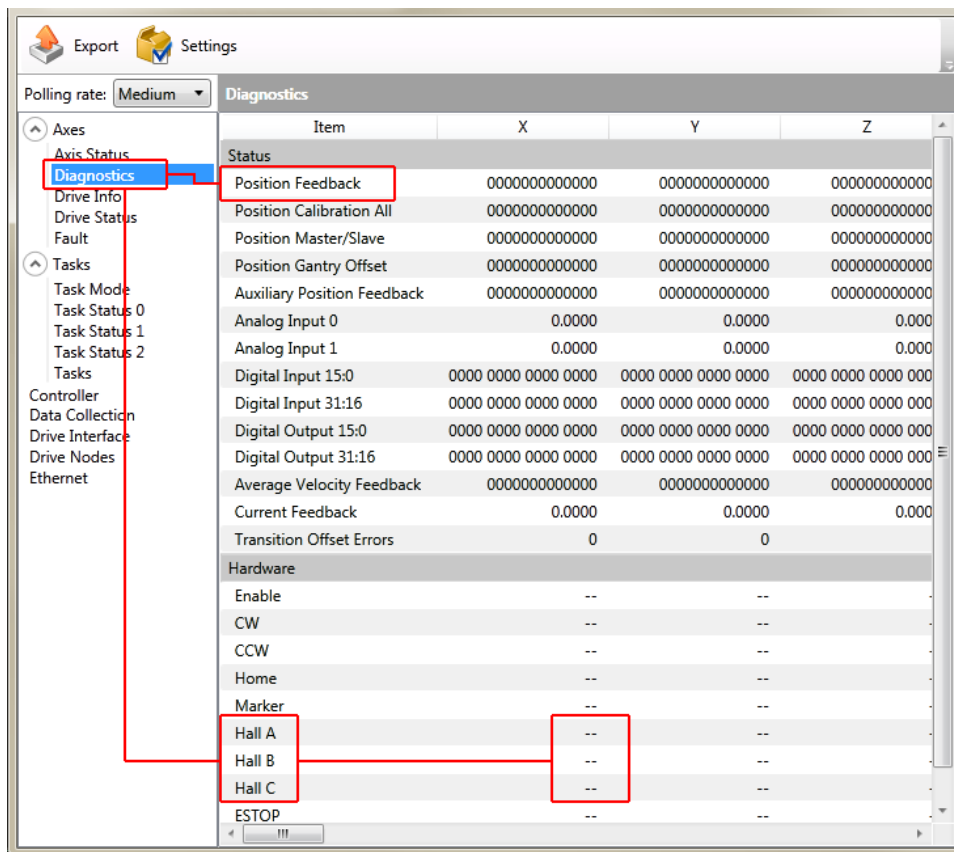


Figure 2-12: Encoder and Hall Signal Diagnostics

2.2.1.2. Brushless Motor Unpowered Motor and Feedback Phasing

Disconnect the motor from the controller and connect the motor in the test configuration shown in Figure 2-13. This method will require a two-channel oscilloscope, a 5V power supply, and six resistors (10,000 ohm, 1/4 watt). All measurements should be made with the probe common of each channel of the oscilloscope connected to a neutral reference test point (TP4, shown in Figure 2-13). Wave forms are shown while moving the motor in the positive direction.

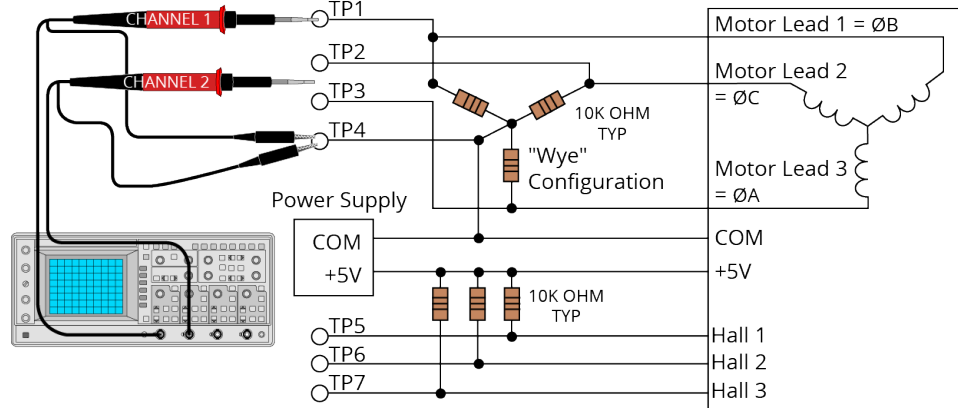


Figure 2-13: Brushless Motor Phasing Oscilloscope Example

With the designations of the motor and Hall leads of a third party motor determined, the motor can now be connected to an Aerotech system. Connect motor lead A to motor connector A, motor lead B to motor connector B, and motor lead C to motor connector C. Hall leads should also be connected to their respective feedback connector pins (Hall A lead to the Hall A feedback pin, Hall B to Hall B, and Hall C to Hall C). The motor is correctly phased when the Hall states align with the Back EMF as shown in (Figure 2-14). Use the CommutationOffset parameter to correct for Hall signal misalignment.

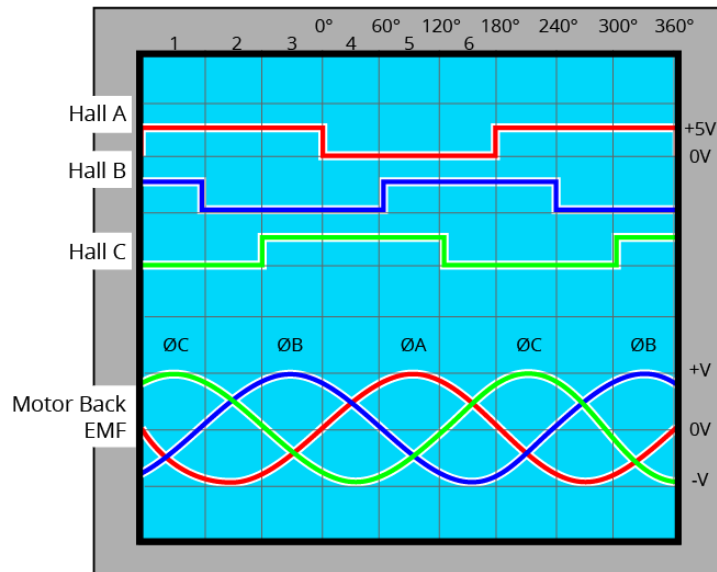


Figure 2-14: Brushless Motor Phasing Goal

2.2.2. DC Brush Motor Connections

The configuration shown in Figure 2-15 is an example of a typical DC brush motor connection. Refer to Section 2.2.2.1. for information on motor phasing.

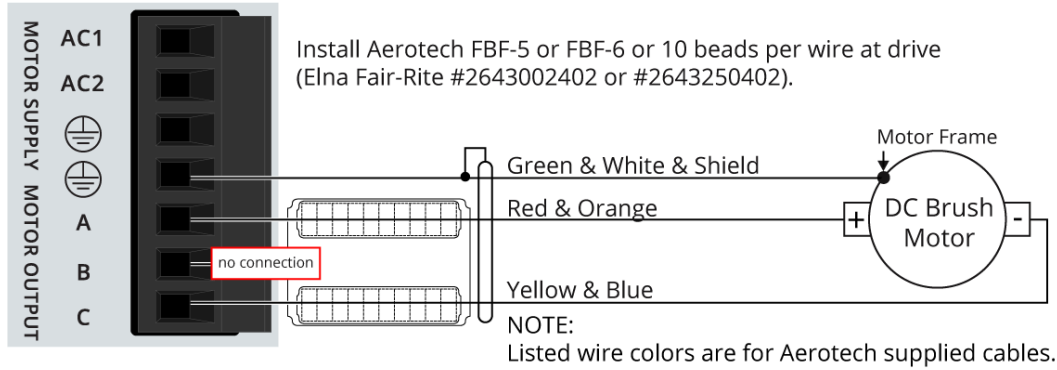


Figure 2-15: DC Brush Motor Configuration

Table 2-11: Wire Colors for Aerotech-Supplied DC Brush Motor Cables

Pin	Wire Color Set 1 ⁽¹⁾	Wire Color Set 2	Wire Color Set 3
⊕	Green & White & Shield ⁽²⁾	Green/Yellow & Shield	Green/Yellow & Shield
A	Red & Orange	Red	Red & Orange
C	Yellow & Blue	Black	Yellow & Blue

(1) Wire Color Set #1 is the typical wire set used by Aerotech.
 (2) "&" (Red & Orange) indicates two wires; "/" (Green/White) indicates a single wire.

2.2.2.1. DC Brush Motor Phasing

A properly phased motor means that the positive motor lead should be connected to the $\emptyset A$ motor terminal and the negative motor lead should be connected to the $\emptyset C$ motor terminal. To determine if the motor is properly phased, connect a voltmeter to the motor leads of an un-powered motor:

1. Connect the positive lead of the voltmeter to the one of the motor terminals.
2. Connect the negative lead of the voltmeter to the other motor terminal.
3. Move or rotate the motor in the positive or clockwise (CW) direction by hand.

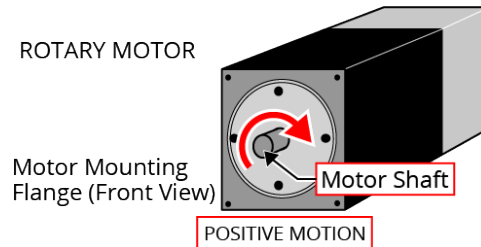


Figure 2-16: Positive Motor Direction

4. If the voltmeter indicates a negative value, swap the motor leads and move the motor by hand in the positive direction, again. When the voltmeter indicates a positive value, the motor leads have been identified.
5. Connect the motor lead from the positive lead of the voltmeter to the $\emptyset A$ motor terminal on the XC4. Connect the motor lead from the negative lead of the voltmeter to the $\emptyset C$ motor terminal on the XC4.

For Aerotech-supplied systems, the motor, encoder and Hall sensors are correctly configured and connection adjustments are not necessary.

2.2.3. Stepper Motor Connections

The configuration shown in Figure 2-17 is an example of a typical stepper motor connection. Refer to Section 2.2.3.1. for information on motor phasing.

In this case, the effective motor voltage is half of the applied bus voltage. For example, an 80V motor bus supply is needed to get 40V across the motor.

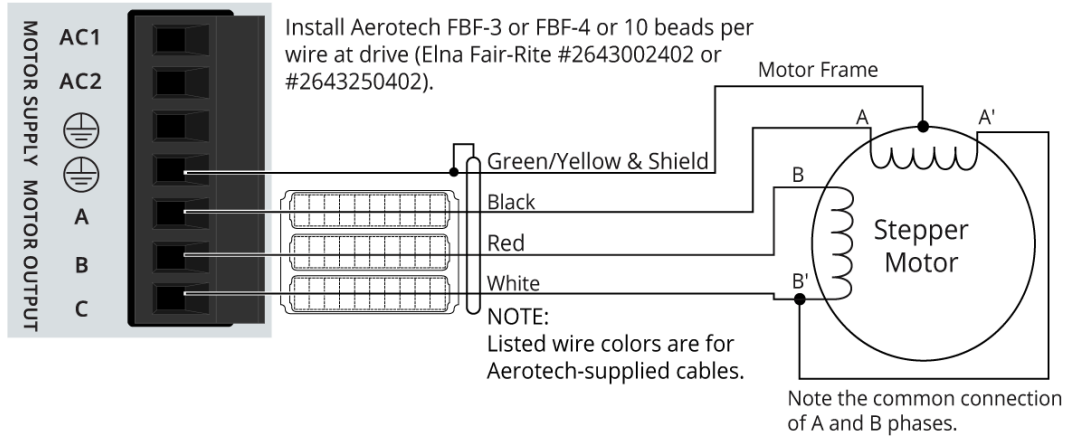


Figure 2-17: Stepper Motor Configuration

Table 2-12: Wire Colors for Aerotech-Supplied Stepper Motor Cables

Pin	Wire Color Set 1 ⁽¹⁾	Wire Color Set 2
⊕	Green/Yellow & Shield ⁽²⁾	Green/Yellow & Shield
A	Black	Brown
B	Red	Yellow
C	White	White & Red

(1) Wire Color Set #1 is the typical wire set used by Aerotech.
 (2) "&" (Red & Orange) indicates two wires; "/" (Green/White) indicates a single wire.

2.2.3.1. Stepper Motor Phasing

A stepper motor can be run with or without an encoder.

Without an Encoder: You do not need to phase the motor.

With an Encoder: Because the end of travel (EOT) limit inputs are relative to motor rotation, it is important to phase the motor.

Run a positive motion command. The motor is phased correctly if there is a positive scaling factor (determined by the CountsPerUnit parameters) and the motor moves in a clockwise direction when you view the motor from the front mounting flange (Figure 2-18). If the motor moves in a counterclockwise direction, swap the motor leads and re-run the command. After the motor has been phased, if you want to change the direction of positive motion, use the ReverseMotionDirection parameter.

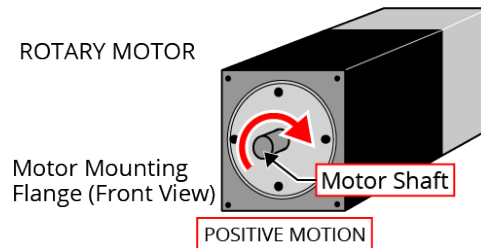


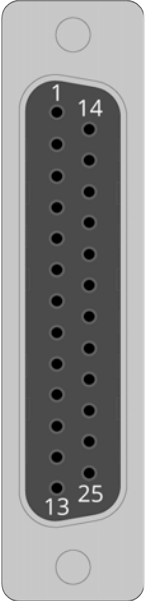
Figure 2-18: Positive Motor Direction

For Aerotech-supplied systems, the motor, encoder and Hall sensors are correctly configured and connection adjustments are not necessary.

2.3. Feedback Connector

The connector pin assignment is shown in [Table 2-13](#) with detailed connection information in the following sections.

Table 2-13: Feedback Connector Pinout

Pin #	Description	In/Out/Bi	Connector
1	Reserved	N/A	
2	Motor Over Temperature Thermistor	Input	
3	+5V Power ⁽¹⁾	N/A	
4	Plug and Play Serial Data (for Aerotech stages only)	Bidirectional	
5	Hall-Effect Sensor B (brushless motors only)	Input	
6	Encoder Marker Reference Pulse -	Input	
	Absolute Encoder Clock -	Output	
7	Encoder Marker Reference Pulse +	Input	
	Absolute Encoder Clock +	Output	
8	Absolute Encoder Data -	Bidirectional	
9	Reserved	N/A	
10	Hall-Effect Sensor A (brushless motors only)	Input	
11	Hall-Effect Sensor C (brushless motors only)	Input	
12	Clockwise End of Travel Limit	Input	
13	Brake Output -	Output	
14	Encoder Cosine +	Input	
15	Encoder Cosine -	Input	
16	+5V Power ⁽¹⁾	N/A	
17	Encoder Sine +	Input	
18	Encoder Sine -	Input	
19	Absolute Encoder Data+	Bidirectional	
20	Signal Common	N/A	
21	Signal Common	N/A	
22	Home Switch Input	Input	
23	Encoder Fault Input	Input	
24	Counterclockwise End of Travel Limit	Input	
25	Brake Output +	Output	

(1) The maximum combined current output is 500 mA.

Table 2-14: Mating Connector Part Numbers for the Feedback Connector

Mating Connector	Aerotech P/N	Third Party P/N
25-Pin D-Connector	ECK00101	FCI DB25P064TXLF
Backshell	ECK00656	Amphenol 17E-1726-2

2.3.1. Primary Encoder Inputs

The primary encoder inputs are accessible through the Feedback connector. Use the PrimaryFeedbackType [A3200: PositionFeedbackType or VelocityFeedbackType] parameter to configure the XC4 to accept an encoder signal type.

Square Wave encoder signals: [Section 2.3.1.1.](#)

Absolute encoder signals: [Section 2.3.1.2.](#)

Sine Wave encoder signals (as permitted by the multiplier option): [Section 2.3.1.3.](#)

You cannot use a sine wave encoder with the -MX1 multiplier option as an input to the PSO. The -MX1 option does not generate emulated quadrature signals.

Refer to [Section 2.3.1.4.](#) for encoder feedback phasing.

Refer to [Section 2.5.](#) for the auxiliary encoder input on the Aux I/O connector.

Table 2-15: Multiplier Options

Option	Primary Encoder Accepts...	Auxiliary Encoder Accepts...
-MX0	Square Wave or Absolute encoders	Square Wave or Absolute encoders
-MX1	Sine Wave, Square Wave, or Absolute encoders	Square Wave or Absolute encoders



IMPORTANT: Physically isolate the encoder wiring from motor, AC power, and all other power wiring

Table 2-16: Primary Encoder Input Pins on the Feedback Connector

Pin #	Description	In/Out/Bi
3	+5V Power ⁽¹⁾	N/A
6	Encoder Marker Reference Pulse -	Input
	Absolute Encoder Clock -	Output
7	Encoder Marker Reference Pulse +	Input
	Absolute Encoder Clock +	Output
8	Absolute Encoder Data -	Bidirectional
14	Encoder Cosine +	Input
15	Encoder Cosine -	Input
16	+5V Power ⁽¹⁾	N/A
17	Encoder Sine +	Input
18	Encoder Sine -	Input
19	Absolute Encoder Data+	Bidirectional
20	Signal Common	N/A
21	Signal Common	N/A

(1) The maximum combined current output is 500 mA.

2.3.1.1. Square Wave Encoder

The XC4 accepts RS-422 square wave encoder signals. The XC4 will generate a feedback fault if it detects an invalid signal state caused by an open or shorted signal connection. Use twisted-pair wiring for the highest performance and noise immunity.

Table 2-17: Square Wave Encoder Specifications

Specification	Value
Encoder Frequency	10 MHz maximum (25 ns minimum edge separation)
x4 Quadrature Decoding	40 million counts/sec

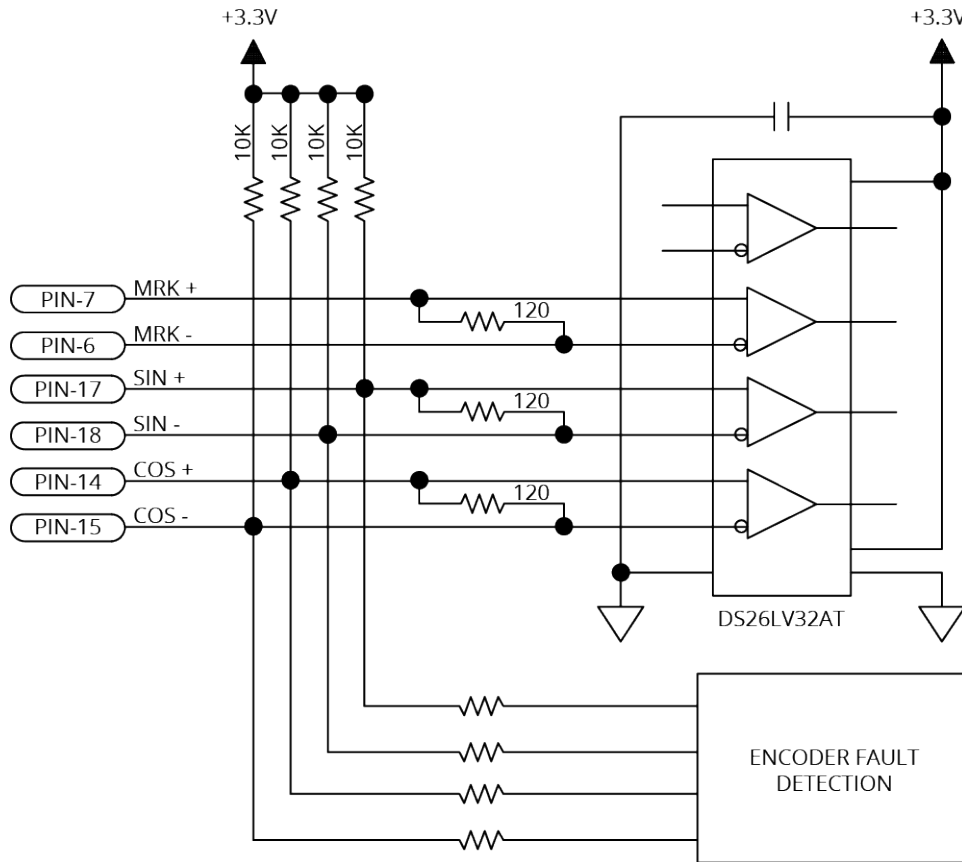


Figure 2-19: Square Wave Encoder Schematic (Feedback Connector)

2.3.1.2. Absolute Encoder

The XC4 retrieves absolute position data along with encoder fault information through a serial data stream from the absolute encoder. Use twisted-pair wiring for the highest performance and noise immunity. You cannot echo an absolute encoder signal.

Refer to [Figure 2-20](#) for the serial data stream interface.

Refer to the Help file for information on how to set up your EnDat or BiSS absolute encoder parameters.

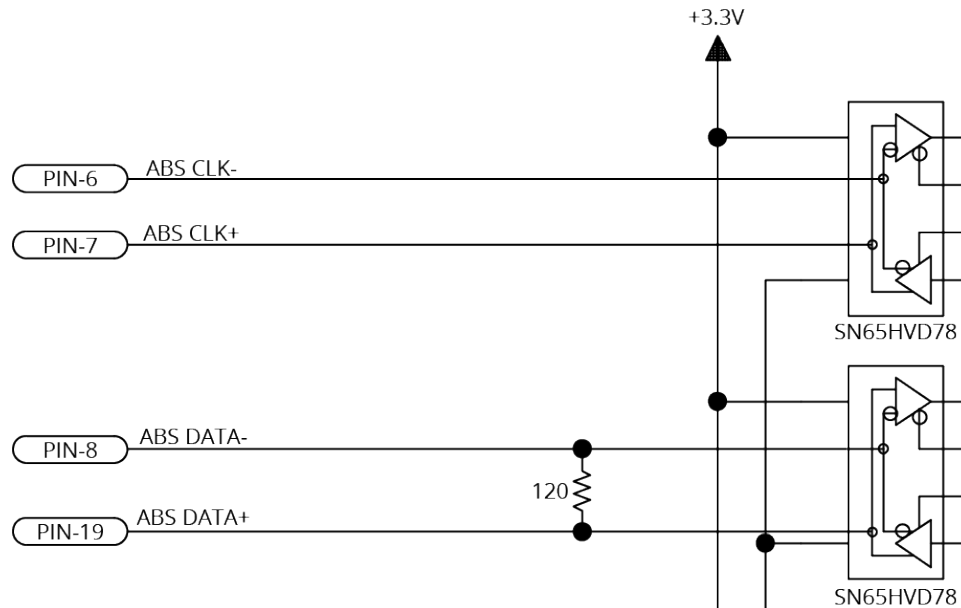


Figure 2-20: Absolute Encoder Schematic (Feedback Connector)

2.3.1.3. Sine Wave Encoder [-MX1 Option]

The Sine Wave Encoder option provides higher positioning resolution by subdividing the fundamental output period of the encoder into smaller increments. The amount of subdivision is specified by the PrimaryEncoderMultiplicationFactor [A3200: EncoderMultiplicationFactor] parameter. Use Encoder Tuning [A3200: Feedback Tuning] to adjust the value of the gain, offset, and phase balance controller parameters to get the best performance. For more information, refer to the Help file.

High resolution or high-speed encoders can require increased bandwidth for correct operation. Use the High Speed Mode of the PrimaryEncoderMultiplierSetup [A3200: EncoderMultiplierSetup] parameter to enable the high bandwidth mode. Because this mode increases sensitivity to system noise, use it only if necessary.

You cannot use a sine wave encoder with the -MX1 multiplier option as an input to the PSO. The -MX1 option does not generate emulated quadrature signals.

For the highest performance, use twisted pair double-shielded cable with the inner shield connected to signal common and the outer shield connected to frame ground. Do not join the inner and outer shields in the cable.

Table 2-18: Sine Wave Encoder Specifications

Specification	Value
Input Frequency (max)	450 kHz, 2 MHz
Input Amplitude ⁽¹⁾	0.6 to 1.75 Vpk-pk
Interpolation Factor (max)	16,384
Input Common Mode	1.5 to 3.5 VDC

(1) Measured as SIN(+) - SIN(-) or COS(+) - COS(-)

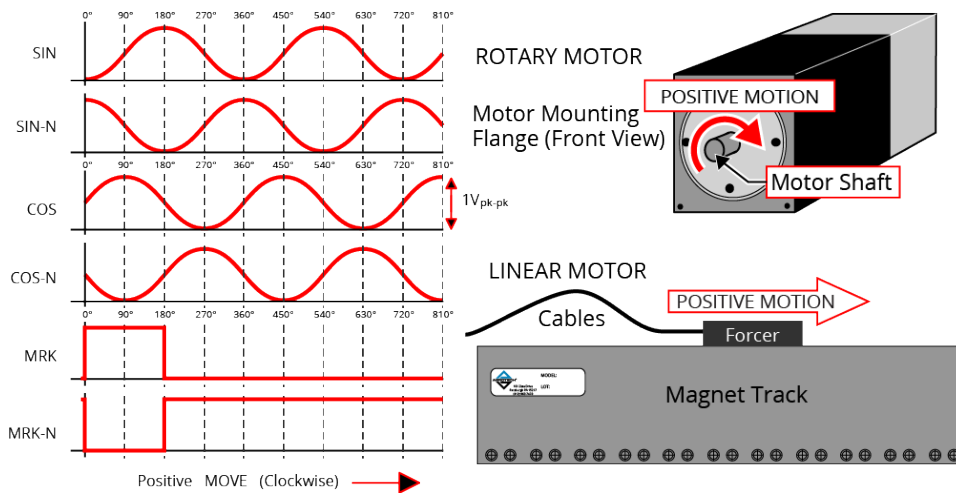


Figure 2-21: Sine Wave Encoder Phasing Reference Diagram

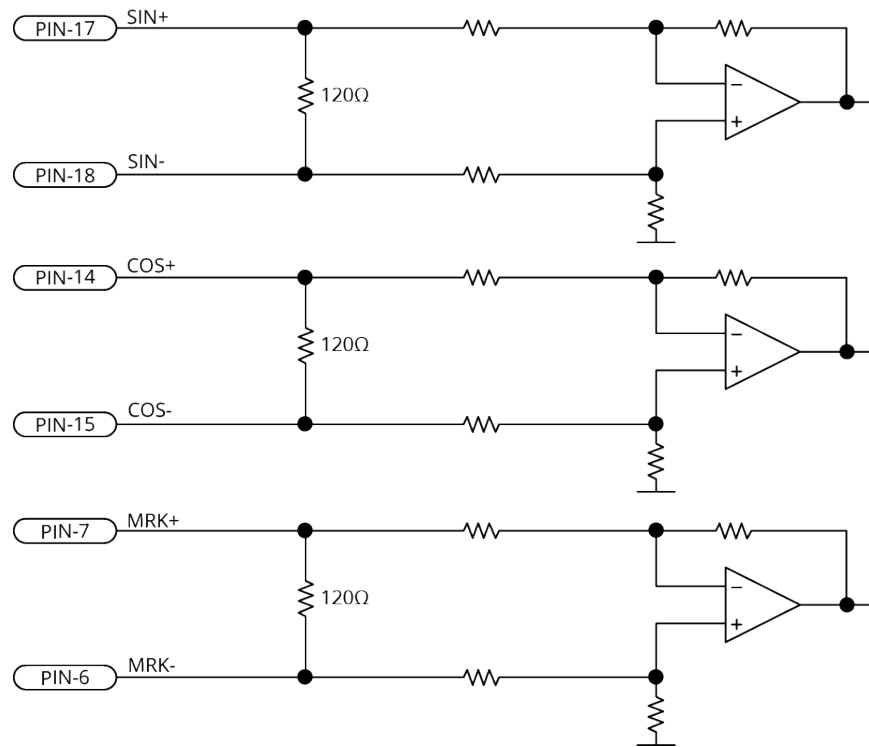


Figure 2-22: Sine Wave Encoder Schematic (Feedback Connector)

2.3.1.4. Encoder Phasing

Incorrect encoder polarity will cause the system to fault when enabled or when a move command is issued. Figure 2-23 illustrates the proper encoder phasing for clockwise motor rotation (or positive forcer movement for linear motors). To verify, move the motor by hand in the CW (positive) direction while observing the position of the encoder in the diagnostics display (see Figure 2-24).

For dual loop systems, the velocity feedback encoder is displayed in the diagnostic display (Figure 2-24).

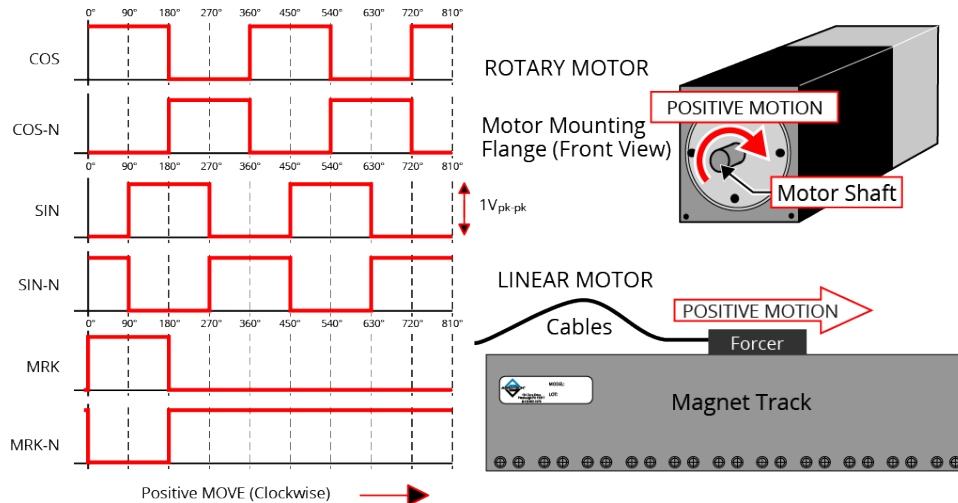


Figure 2-23: Encoder Phasing Reference Diagram (Standard)



IMPORTANT: Encoder manufacturers may refer to the encoder signals as A, B, and Z. The proper phase relationship between signals is shown in Figure 2-23.

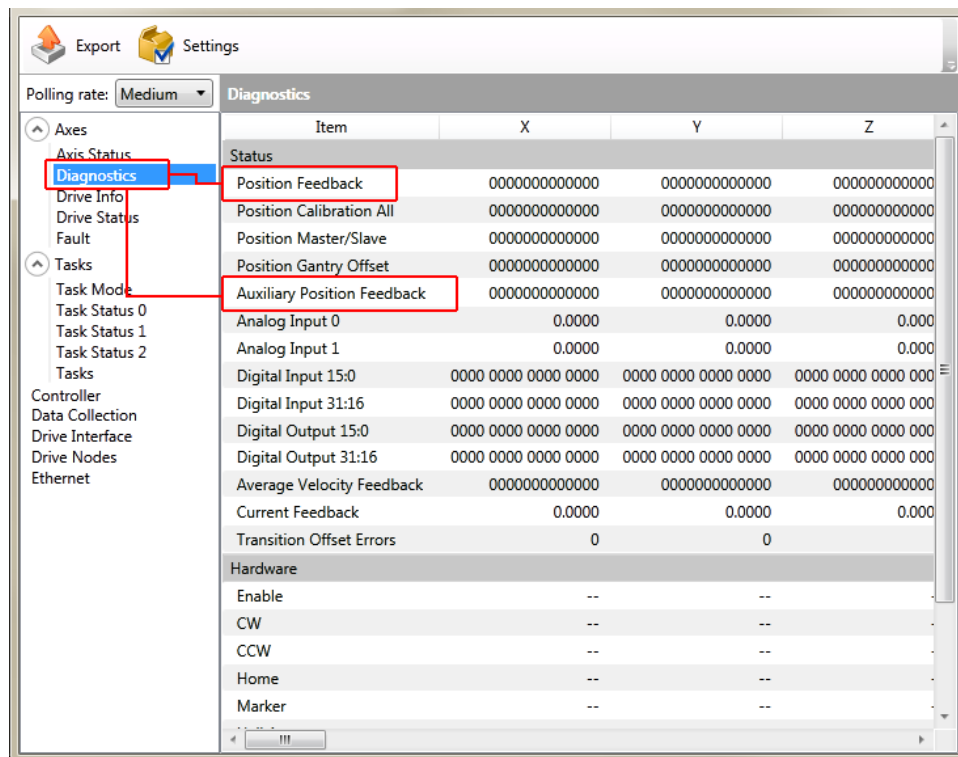


Figure 2-24: Position Feedback in the Diagnostic Display

2.3.2. Hall-Effect Inputs

The Hall-effect switch inputs are recommended for AC brushless motor commutation but not absolutely required. The Hall-effect inputs accept 5 VDC level signals. Hall states (0,0,0) or (1,1,1) are invalid and will generate a "Hall Fault" axis fault.

Refer to [Section 2.2.1.1](#), for Hall-effect device phasing.

Table 2-19: Hall-Effect Feedback Pins on the Feedback Connector

Pin #	Description	In/Out/Bi
3	+5V Power ⁽¹⁾	N/A
5	Hall-Effect Sensor B (brushless motors only)	Input
10	Hall-Effect Sensor A (brushless motors only)	Input
11	Hall-Effect Sensor C (brushless motors only)	Input
16	+5V Power ⁽¹⁾	N/A
20	Signal Common	N/A
21	Signal Common	N/A

(1) The maximum combined current output is 500 mA.

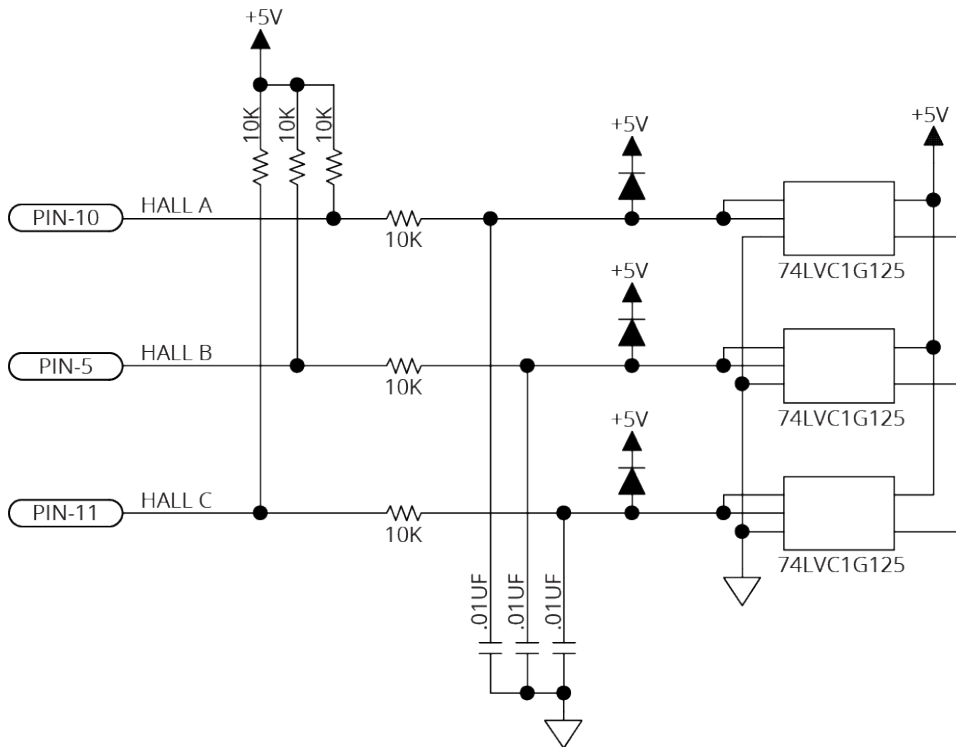


Figure 2-25: Hall-Effect Inputs Schematic (Feedback Connector)

2.3.3. Thermistor Input

The thermistor input is used to detect a motor over temperature condition by using a positive temperature coefficient sensor. As the temperature of the sensor increases, so does the resistance. Under normal operating conditions, the resistance of the thermistor is low which will result in a low input signal. As the increasing temperature causes the thermistor's resistance to increase, the sensor will trigger an over temperature fault.

The thermistor is connected between Pin 2 and Signal Common. The nominal trip value of the sensor is 1.385 k Ω . The circuit includes a 12 k Ω internal pull-up resistor which corresponds to a trip voltage of +0.52 V.

Table 2-20: Thermistor Input Pin on the Feedback Connector

Pin #	Description	In/Out/Bi
2	Motor Over Temperature Thermistor	Input

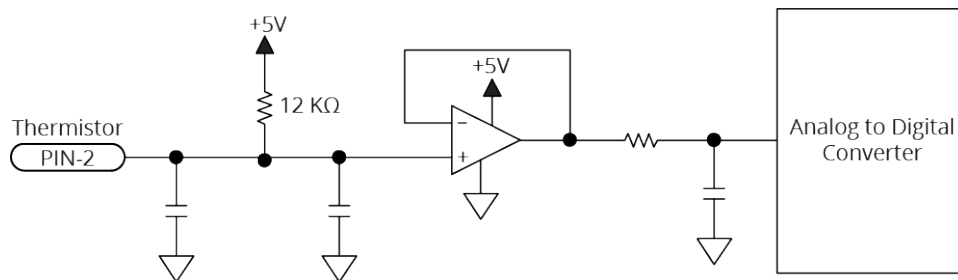


Figure 2-26: Thermistor Input Schematic (Feedback Connector)

2.3.4. Encoder Fault Input

The encoder fault input is for use with encoders that have a fault output. This is provided by some manufactures and indicates a loss of encoder function. The active state of this input is parameter configurable and the controller should be configured to disable the axis when the fault level is active. The nominal trip voltage of the encoder fault input is +2.5 V.

Table 2-21: Encoder Fault Input Pin on the Feedback Connector

Pin #	Description	In/Out/Bi
23	Encoder Fault Input	Input

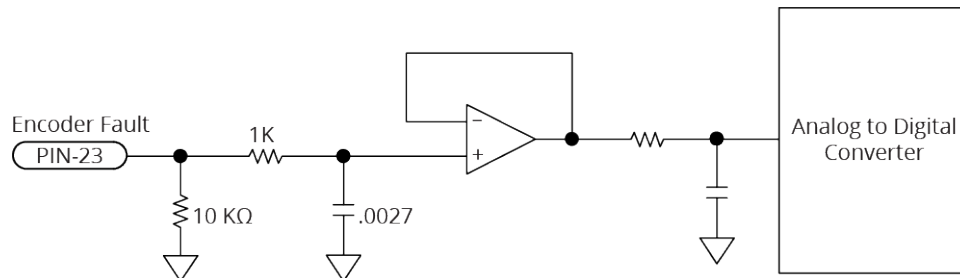


Figure 2-27: Encoder Fault Input Schematic (Feedback Connector)

2.3.5. End of Travel and Home Limit Inputs

End of Travel (EOT) limits are required to define the end of the physical travel on linear axes. Positive or clockwise motion is stopped by the clockwise (CW) end of travel limit input. Negative or counterclockwise motion is stopped by the counterclockwise (CCW) end of travel limit input. The Home Limit switch can be parameter configured for use during the home cycle, however, the CW or CCW EOT limit is typically used instead. All of the end-of-travel limit inputs accept 0-5 VDC level signals. Limit directions are relative to the encoder polarity in the diagnostics display (refer to [Figure 2-30](#)).

Table 2-22: End of Travel and Home Limit Pins on the Feedback Connector

Pin #	Description	In/Out/Bi
12	Clockwise End of Travel Limit	Input
16	+5V Power	N/A
20	Signal Common	N/A
21	Signal Common	N/A
22	Home Switch Input	Input
24	Counterclockwise End of Travel Limit	Input

The active state (High/Low) of the EOT limits is software selectable (by the EndOfTravelLimitSetup axis parameter). [Figure 2-28](#) shows the possible wiring configurations for normally-open and normally-closed switches and the parameter setting to use for each configuration.



IMPORTANT: Use NPN-type normally-closed limit switches (Active High) to provide fail-safe behavior in the event of an open circuit.

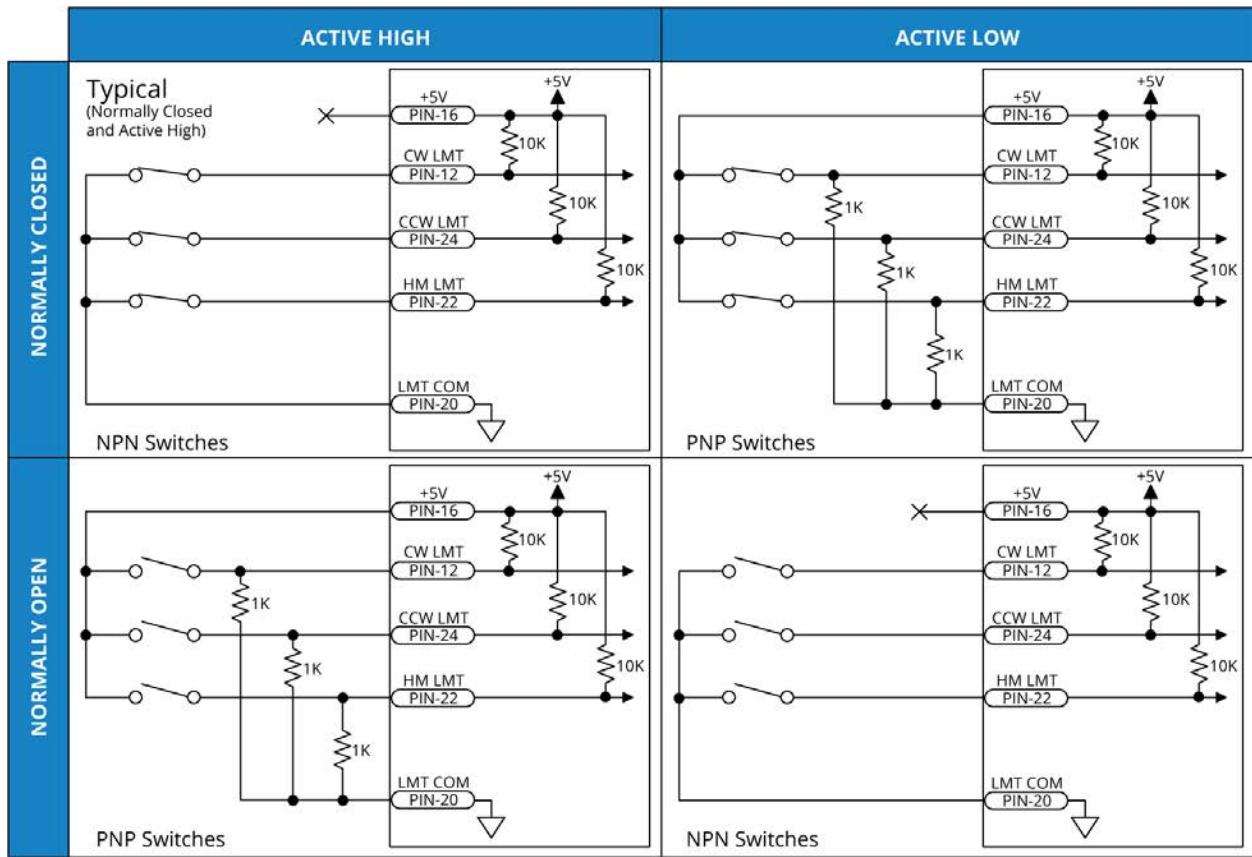


Figure 2-28: End of Travel and Home Limit Input Connections

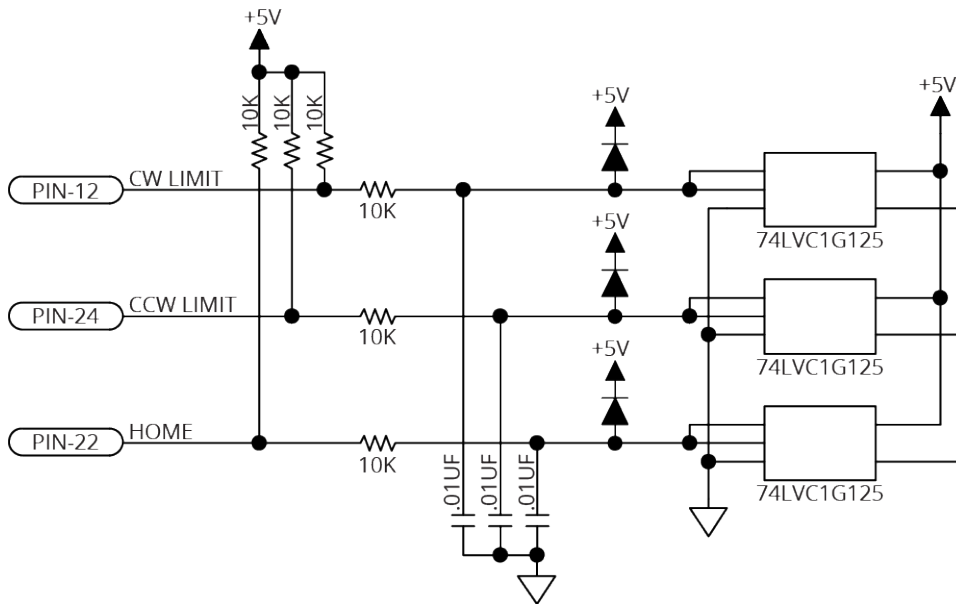


Figure 2-29: End of Travel and Home Limit Input Schematic (Feedback Connector)

2.3.5.1. End of Travel and Home Limit Phasing

If the EOT limits are reversed, you will be able to move further into a limit but be unable to move out. To correct this, swap the connections to the CW and CCW inputs at the Feedback connector or swap the CW and CCW limit functionality in the software using the EndOfTravelLimitSetup parameter. View the logic level of the EOT limit inputs in the Diagnostics display (shown in Figure 2-30).

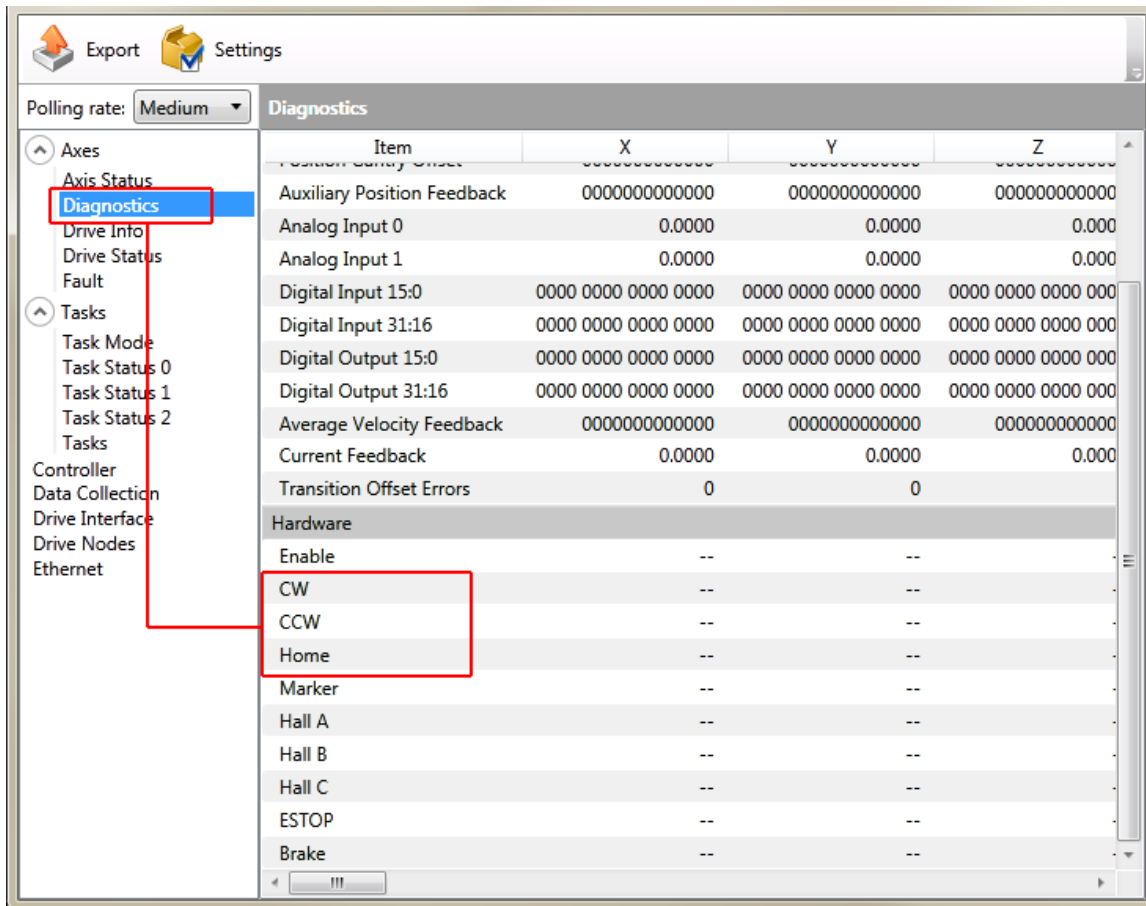


Figure 2-30: End of Travel and Home Limit Input Diagnostic Display

2.3.6. Brake Outputs

The XC4 has a dedicated brake control circuit. Configure the brake with the BrakeSetup [A3200: EnableBrakeControl] parameter for automatic control (typical). You can also use software commands to directly control the brake output.

Refer to [Section 2.6](#) for more information on powering the brake circuit.

Table 2-23: Brake Output Pins on the Feedback Connector

Pin #	Description	In/Out/Bi
13	Brake Output -	Output
25	Brake Output +	Output

Table 2-24: Brake Control Specifications

Specification	Value
Maximum Voltage	24 VDC
Maximum Current	1 A

A varistor must be connected across the brake to minimize voltage transients.

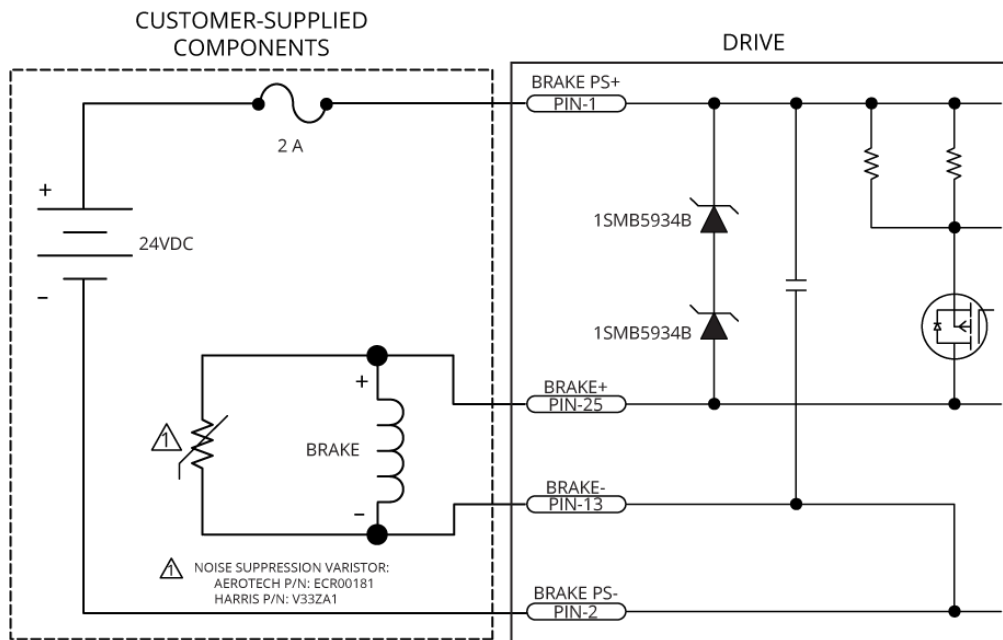


Figure 2-31: Brake Connected to the 25-Pin Feedback Connector (Typical)

2.4. Safe Torque Off Input (STO)

The STO circuit is comprised of two identical channels, each of which must be energized in order for the XC4 to produce motion. Each STO input is opto-isolated and accepts 24V levels directly without the need for external current limiting resistors.



IMPORTANT: The XC4 might be equipped with an STO bypass circuit board. The bypass circuit board defeats the STO safety circuit and allows the system to run at all times. To use the STO safety functionality, remove the circuit board and make connections as outlined in this section.



IMPORTANT: The application circuit and its suitability for the desired safety level is the sole responsibility of the user of the XC4.



WARNING: STO wires must be insulated to prevent short circuits between connector pins. The primary concern is a short circuit between STO 1 IN and STO 2 IN wire strands.

Table 2-25: STO Connector Pinout

Pin #	Signal	Description	In/Out/Bi	Connector
1	Power Supply +	Used to defeat STO by connecting to STO 1 IN and STO 2 IN	N/A	
2	STO 1 IN	STO Channel 1 Positive Input	Input	
3	RETURN	STO Negative Input	Input	
4	STO 2 IN	STO Channel 2 Positive Input	Input	
5	Power Supply -	Used to defeat STO by connecting to RETURN	N/A	

Table 2-26: Mating Connector Part Numbers for the STO Connector

Description	Aerotech P/N	Phoenix P/N	Tightening Torque (Nm)	Wire Size: AWG [mm ²]
5-Pin Terminal Block	ECK02393	1827622	0.22 - 0.25	2.5 - 0.05 [14-30]

Table 2-27: STO Electrical Specifications

Status	Value
STO off (motion allowed)	18-24 V, 7 ma
STO on (safe state entered, no motion)	0-6 V
Recommended Wire Gauge	22-26 AWG (0.5 - 0.14 mm ²)
STO System Power Supply	PELV
STO Wire Length (maximum)	50 m

Figure 2-32 shows one safety device connected to multiple XC4s in parallel.



WARNING: The XC4 does not check for short circuits on the external STO wiring. If this is not done by the external safety device, short circuits on the wiring must be excluded. Refer to EN ISO 13849-2. For Category 4 systems, the exclusion of short circuits is mandatory.

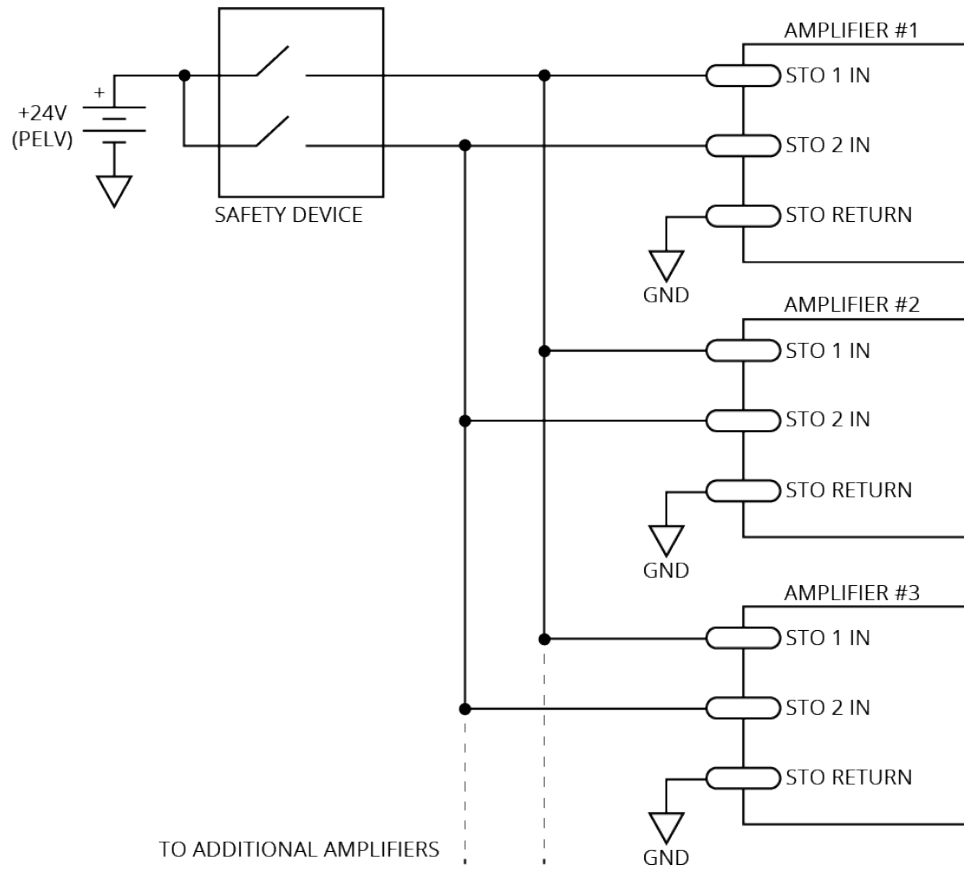


Figure 2-32: Typical Configuration

2.4.1. STO Standards

Table 2-28 describes and specifies the safety requirements at the system level for the Safe Torque Off (STO) feature of the XC4. This assumes that diagnostic testing is performed according to Section 2.4.4. and Table 2-29.

Table 2-28: STO Standards

Standard	Maximum Achievable Safety
EN/IEC 61800-5- 2:2016	SIL 3
EN/IEC 61508-1:2010	SIL 3
EN/IEC 61508-2:2010	SIL 3
EN ISO 13849-1:2015	Category 4, PL e
EN/IEC 62061:2005 with Amendments	SIL 3

Table 2-29: STO Standards Data

Standard	Value
EN ISO 13849-1:2015	MTTF _D > 1000 years, DC _{AVG} 99% Maximum PL e, Category 4
EN ISO 13849-1:2015 EN/IEC 61508	Lifetime = 20 years No proof test required Interval for manual STO test: <ul style="list-style-type: none"> Once per year for SIL2/PL d/category 3 Once per three months for SIL3/PL e/category 3 Once per day for SIL3/PL e/category 4
EN/IEC 61508	SIL3 PFH < 3 FIT SFF > 99%

2.4.2. STO Functional Description

The motor can only be activated when voltage is applied to both STO 1 and STO 2 inputs. The STO state will be entered if power is removed from either the STO 1 or the STO 2 inputs. When the STO state is entered, the motor cannot generate torque or force and is therefore considered safe.

The STO function is implemented with two redundant channels in order to meet stated performance and SIL levels. STO 1 disconnects the high side power amplifier transistors and STO 2 disconnects the low side power amplifier transistors. Disconnecting either set of transistors effectively prevents the XC4 from being able to produce motion.

The XC4 software monitors each STO channel and will generate an Emergency Stop software fault when either channel signals the stop state. Each STO channel contains a fixed delay which allows the XC4 to perform a controlled stop before the power amplifier transistors are turned off.

A typical configuration requiring a controlled stop has the Emergency Stop Fault mask bit set in the FaultMask, FaultMaskDecel, and FaultMaskDisable parameters. This stops the axis using the rate specified by the AbortDecelRate parameter. The software will disable the axis as soon as the deceleration ramp is complete. This is typically configured to occur before the STO channel turns off the power amplifier transistors.

The software controlled stop functionality must be excluded when considering overall system safety. This is because the software is not safety rated and cannot be included as part of the safety function.

The XC4 will tolerate short diagnostic pulses on the STO 1+ and STO 2+ inputs. The parameter "STOPulseFilter" specifies the maximum pulse width that the XC4 will ignore.

To resume normal operation, apply power to both STO 1 and STO 2 inputs and use the *Acknowledge All* button or the AcknowledgeAll() or FaultAcknowledge() function to clear the Emergency Stop software fault. The recommended use of the Emergency Stop Fault fault mask bits prevent the system from automatically restarting.

You can achieve longer delay times through the use of an external delay timer, such as the Omron G9SA-321 Safety Relay Unit. Place this device between the system ESTOP wiring and the XC4's STO inputs. Connect the ESTOP signal directly to a digital input, in addition to the external timer, to allow the XC4 to begin a software-controlled stop as soon as the ESTOP signal becomes active. Use the EmergencyStopFaultInput [A3200: ESTOPFaultInput] parameter to configure a digital input as an ESTOP input.

Non-standard STO delay times are provided by special factory order. In this case, the non-standard STO delay time is indicated by a label placed on the slice amplifier's main connector (STO DELAY = xx sec).

Table 2-30: STO Signal Delay

	Value
STO Time Delay	450-550 msec

Table 2-31: Motor Function Relative to STO Input State

STO 1	STO 2	Motor Function
Unpowered	Unpowered	No force/torque
Unpowered ⁽¹⁾	Powered ⁽¹⁾	No force/torque
Powered ⁽¹⁾	Unpowered ⁽¹⁾	No force/torque
Powered	Powered	Normal Operation

1. This is considered a Fault Condition since STO 1 and STO 2 do not match. Refer to [Section 2.4.4](#).

2.4.3. STO Startup Validation Testing

Verify the state of the STO 1 and STO 2 channels by manually activating the external STO hardware. Each STO channel must be tested separately in order to detect potential short circuits between the channels. The current state of the STO 1 and STO 2 inputs is shown in the Status Utility. A “-” indicates that the STO input is powered by a high voltage level (24 V). An “ON” indicates that the voltage source has been removed from the input (open circuit or 0 V), and that the STO channel is in the safe state.



DANGER: The STO circuit does not remove lethal voltage from the motor terminals. AC mains power must be removed before servicing.

2.4.4. STO Diagnostics

Activation of STO means removing power from the XC4’s STO inputs. This is typically done by pressing the emergency stop switch. The XC4 initiates a diagnostic check every time the STO is activated after the Diagnostic Test Delay Time has elapsed. The diagnostic check verifies that each channel has entered the safe state. The XC4 is held in the safe state if it determines that one of the channels has not properly entered the safe state. An open circuit or short to 24 V in either STO channel will result in this condition (refer to Section 2.4.3.). The Status Utility screen can be used to verify the levels of the STO input signals while trouble shooting.

In order to meet the listed SIL level, the STO circuit must be activated (power removed from both inputs) according to the interval specified in Table 2-29.

Table 2-32: STO Timing

Time	Description	Value
T1	STO Delay Time (STO input active to motor power off)	450-550 msec
T2	STO deactivated to motor power on (the software is typically configured so that the motor does not automatically re-energize).	< 1 msec
T3	Diagnostic Test Delay Time	550-610 msec

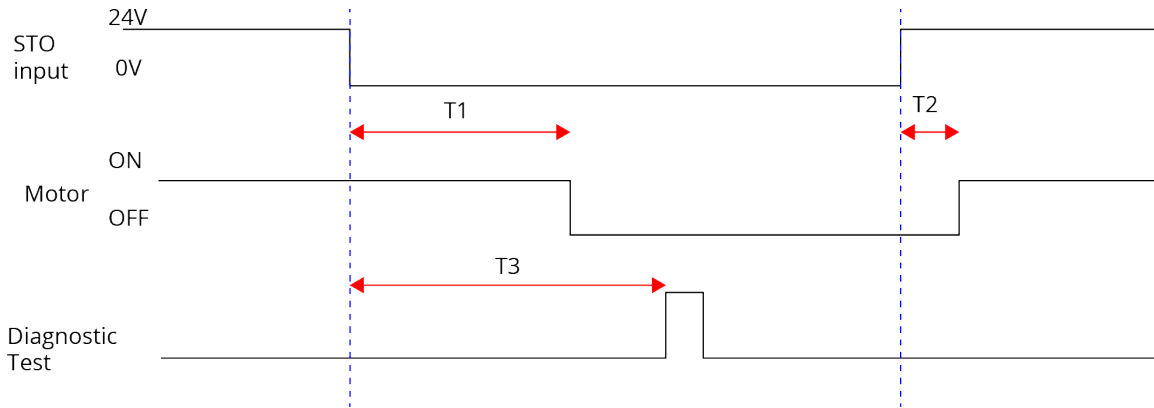


Figure 2-33: STO Timing

The software is typically configured to execute a controlled stop when the STO state is first detected. If power is reapplied to the STO inputs before the STO Delay Time, an STO hardware shutdown will not occur but a software stop may, depending on the width of the STO pulse. The controller will ignore STO active pulses shorter in length than the STOPulseFilter parameter setting.

2.5. Auxiliary I/O Connector

The Auxiliary I/O connector has 1 analog input, 6 digital inputs, 1 analog output, 4 digital outputs, a secondary line driver encoder input, and a secondary absolute encoder interface.

Table 2-33: Auxiliary I/O Connector Pinout

Pin#	Description	In/Out/Bi	Connector
1	Auxiliary Sine +	Bidirectional	
	Absolute Encoder Data +	Bidirectional	
2	Auxiliary Sine -	Bidirectional	
	Absolute Encoder Data -	Bidirectional	
3	High-Speed Input 20 + / PSO External Sync. +	Input	
4	High-Speed Input 20 - / PSO External Sync. -	Input	
5	High-Speed Input 21 +	Input	
6	High-Speed Input 21 -	Input	
7	Digital Output 0	Output	
8	Digital Output 1	Output	
9	Digital Output 2	Output	
10	Auxiliary Cosine +	Bidirectional	
	Absolute Encoder Clock +	Output	
11	Auxiliary Cosine-	Bidirectional	
	Absolute Encoder Clock -	Output	
12	+5 Volt (500 mA max)	N/A	
13	Analog Input 0+ (Differential)	Input	
14	Analog Input 0- (Differential)	Input	
15	Digital Output Common	N/A	
16	Digital Output 3	Output	
17	Digital Input 0 / CCW EOT Input ⁽¹⁾	Input	
18	Digital Input 1 / CW EOT Input ⁽¹⁾	Input	
19	Auxiliary Marker- / PSO output ⁽²⁾ / TTL Output	Bidirectional	
20	Auxiliary Marker+ / PSO output ⁽²⁾	Bidirectional	
21	Common	N/A	
22	Analog Output 0	Output	
23	Analog Common	N/A	
24	Digital Input Common	N/A	
25	Digital Input 2 / Home Input ⁽¹⁾	Input	
26	Digital Input 3	Input	

(1) Software configured option
(2) For PSO, refer to [Section 2.5.2](#).

Table 2-34: Mating Connector Part Numbers for the Auxiliary I/O Connector

Mating Connector	Aerotech P/N	Third Party P/N
Connector	ECK01259	Kycon K86-AA-26P
Backshell	ECK01022	Amphenol 17-1725-2

NOTE: These items are provided as a set under the Aerotech P/N: MCK-26HDD.

2.5.1. Auxiliary Encoder Inputs

The Auxiliary Encoder connector gives you a second encoder input channel. This channel is typically used for dual loop applications.

Use the AuxiliaryFeedbackType [A3200: PositionFeedbackType or VelocityFeedbackType] parameter to configure the XC4 to accept an encoder signal type.

Square Wave encoder signals: [Section 2.5.1.1.](#)

Absolute encoder signals: [Section 2.5.1.2.](#)

You can configure the Auxiliary Encoder interface as an output that will transmit encoder signals for external use. Use the DriveEncoderOutputConfigureInput() function [A3200: EncoderDivider parameter] to configure the Sine \pm and Cosine \pm connector pins as RS-422 outputs. You can only echo incremental square wave primary encoder inputs. You cannot use the absolute encoder interface when you echo incremental signals.

Table 2-35: Auxiliary Encoder Pins on the Auxiliary I/O Connector

Pin#	Description	In/Out/Bi
1	Auxiliary Sine +	Bidirectional
	Absolute Encoder Data +	Bidirectional
2	Auxiliary Sine -	Bidirectional
	Absolute Encoder Data -	Bidirectional
10	Auxiliary Cosine +	Bidirectional
	Absolute Encoder Clock +	Output
11	Auxiliary Cosine-	Bidirectional
	Absolute Encoder Clock -	Output
12	+5 Volt (500 mA max)	N/A
19	Auxiliary Marker- / PSO output ⁽²⁾ / TTL Output	Bidirectional
20	Auxiliary Marker+ / PSO output ⁽²⁾	Bidirectional
21	Common	N/A

(2) For PSO, refer to [Section 2.5.2.](#)

2.5.1.1. Square Wave Encoder

The XC4 accepts RS-422 square wave encoder signals. The XC4 will generate a feedback fault if it detects an invalid signal state caused by an open or shorted signal connection. Use twisted-pair wiring for the highest performance and noise immunity.

Table 2-36: Square Wave Encoder Specifications

Specification	Value
Encoder Frequency	10 MHz maximum (25 ns minimum edge separation)
x4 Quadrature Decoding	40 million counts/sec

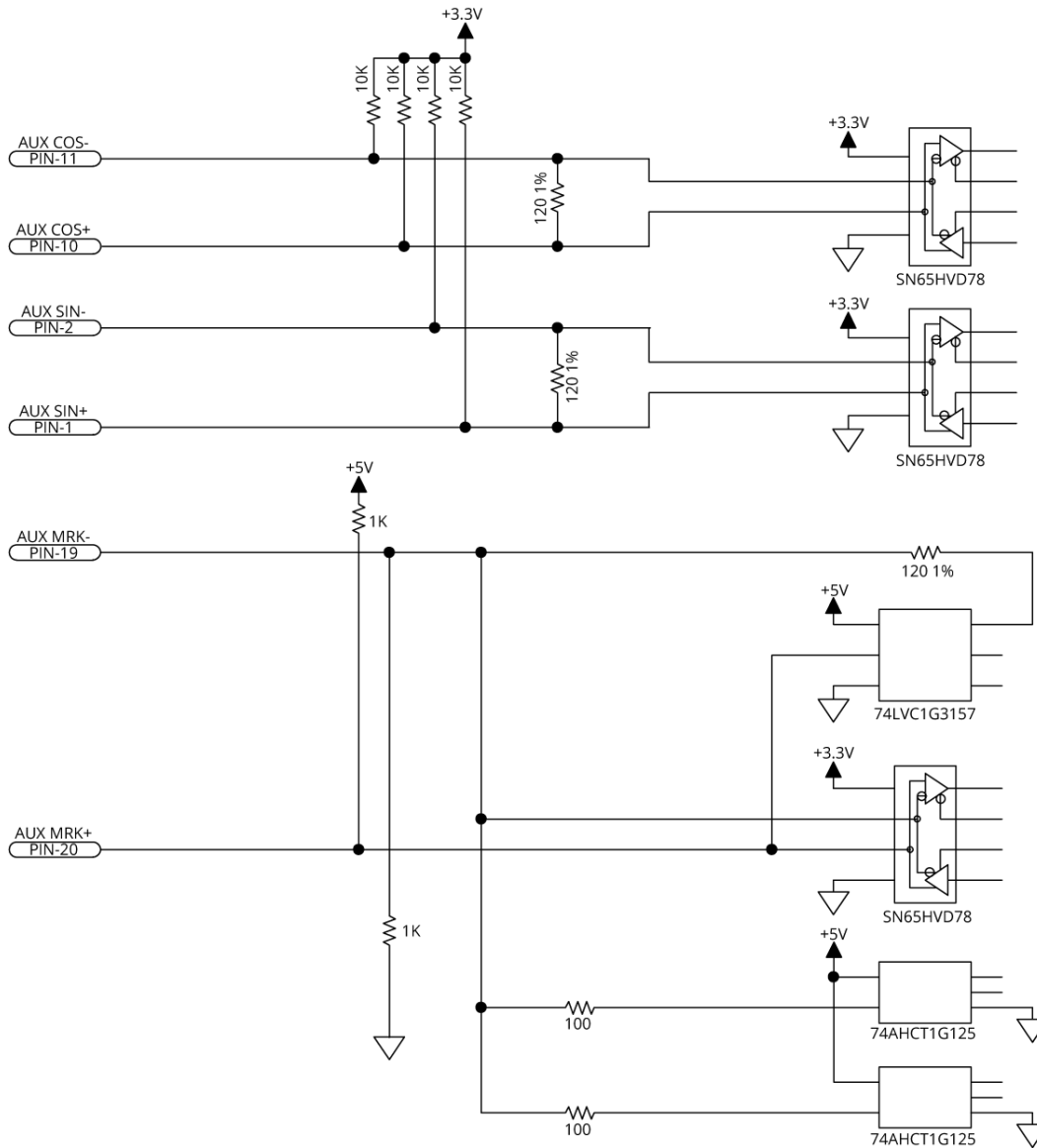


Figure 2-34: Square Wave Encoder Interface (Aux I/O Connector)

2.5.1.2. Absolute Encoder

The XC4 retrieves absolute position data along with encoder fault information through a serial data stream from the absolute encoder. Use twisted-pair wiring for the highest performance and noise immunity. You cannot use an absolute encoder with incremental signals on the Auxiliary I/O Connector.

Refer to [Figure 2-35](#) for the serial data stream interface.

Refer to the Help file for information on how to set up your EnDat or BiSS absolute encoder parameters.

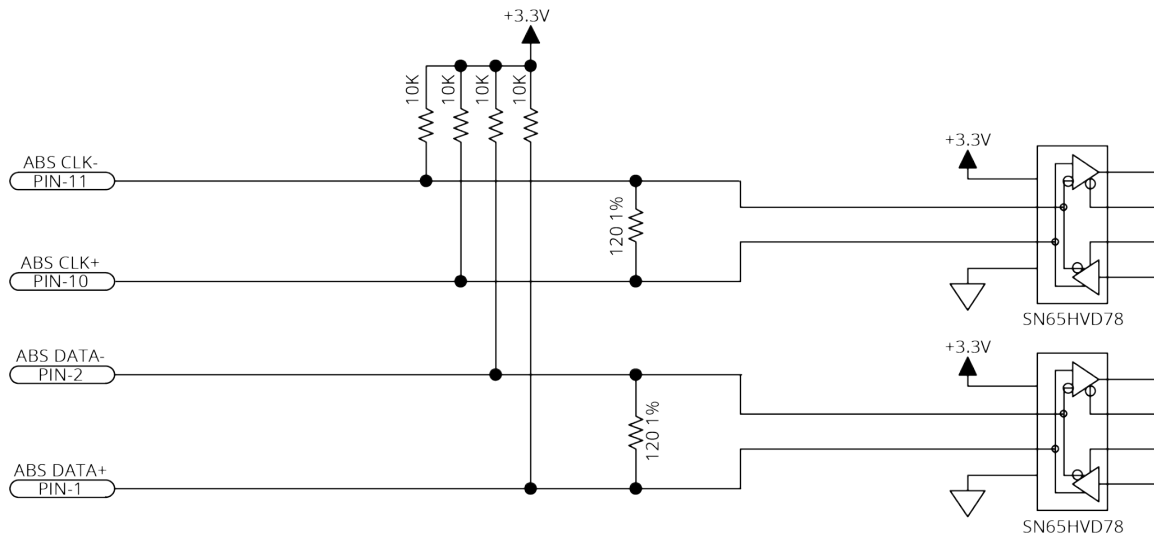


Figure 2-35: Absolute Encoder Schematic (Auxiliary I/O Connector)

2.5.2. Position Synchronized Output (PSO)

The PSO signal is available on the dual-function AUX Marker/PSO signal lines. Use the PSO pulse external sync functions [A3200: PSOOUTPUT PULSE EXTSYNC command] to configure the auxiliary marker as an output. Refer to the Help file for more information.

Use the PsoOutputConfigureOutput() function [A3200: PSOOUTPUT CONTROL command] to transmit the PSO output signal on the Marker \pm pins differentially. Or, use the PsoOutputConfigureOutput() function [A3200: PSOOUTPUT CONTROL command] to configure the Marker - pin as a 5V TTL PSO output.

You cannot use a sine wave encoder with the -MX1 multiplier option as an input to the PSO. The -MX1 option does not generate emulated quadrature signals.

The differential signal format is recommended when using long cable lengths in noisy environments or when high frequency pulse transmission is required. It is best to locate the line receiver close to the receiving electronics. A 5 V TTL signal is used to drive an opto coupler or general purpose TTL input. This signal is active high and is driven to 5 V when a PSO fire event occurs. When the drive is reset or after initial power up, the PSO pins (refer to [Table 2-38](#)), are not actively driven and the fail safe state is defined by pull-up and pull-down resistors as shown in [Figure 2-36](#).

The -EB1 I/O option board has additional PSO signal formats. Refer to [Section 3.5](#). for more information.

Table 2-37: PSO Specifications

Specification		Value
Output	TTL	5 V, 16 mA (max)
Maximum PSO Output (Fire) Frequency	TTL	12.5 MHz
	RS-422	12.5 MHz
Output Latency [Fire event to output change]	TTL	15 ns
	RS-422	15 ns

Table 2-38: PSO Pins on the Auxiliary I/O Connector

Pin#	Description	In/Out/Bi
19	Auxiliary Marker- / PSO output / TTL Output	Bidirectional
20	Auxiliary Marker+ / PSO output	Bidirectional
21	Common	N/A

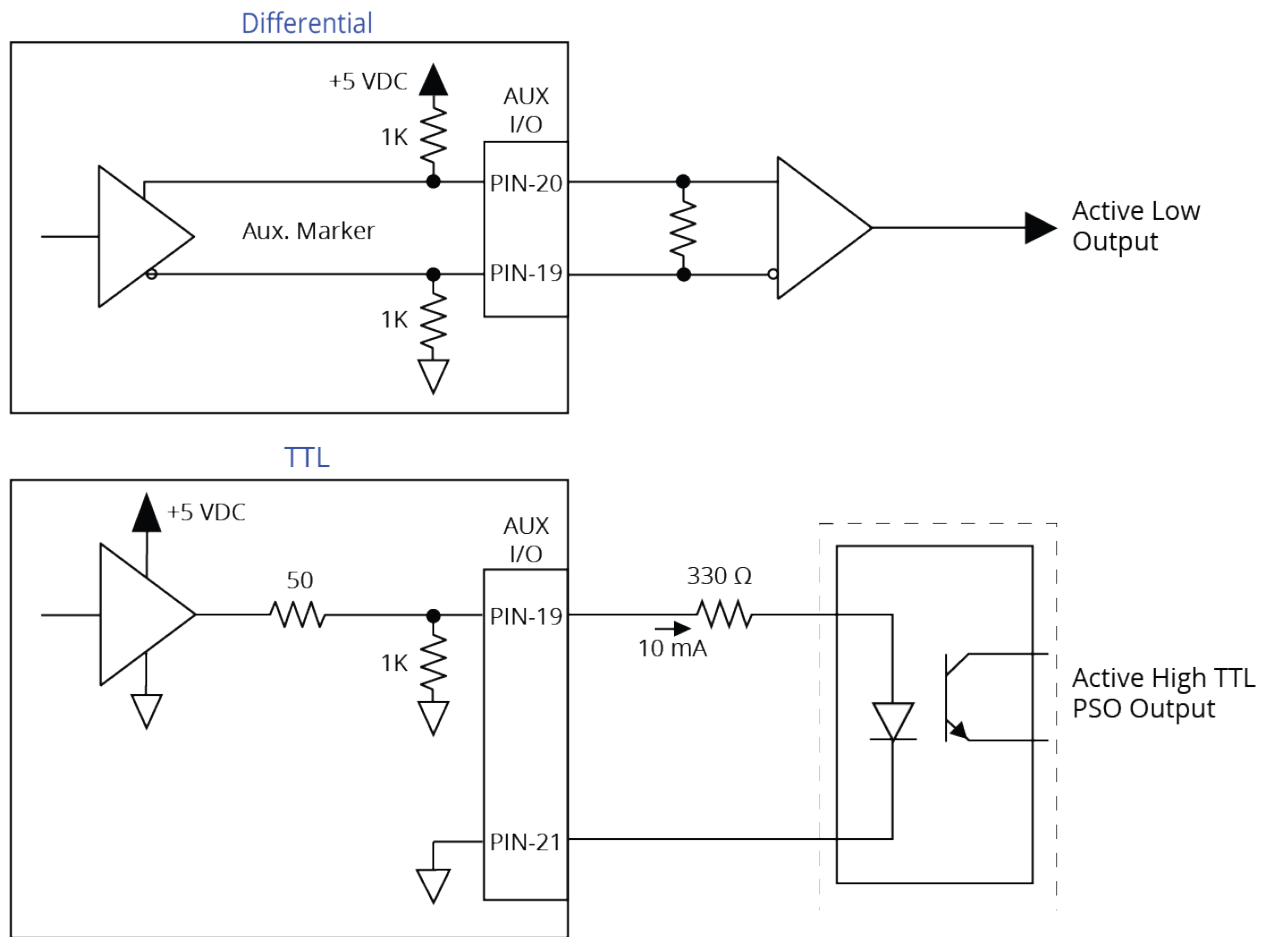


Figure 2-36: PSO Interface

2.5.3. Digital Outputs

Optically-isolated solid-state relays drive the digital outputs. You can connect the digital outputs in current sourcing or current sinking mode but you must connect all four outputs in the same configuration. Refer to [Figure 2-38](#) and [Figure 2-39](#).

You must install suppression diodes on digital outputs that drive relays or other inductive devices. To see an example of a current sourcing output that has diode suppression, refer to [Figure 2-38](#). To see an example of a current sinking output that has diode suppression, refer to [Figure 2-39](#).

The digital outputs are not designed for high-voltage isolation applications and they should only be used with ground-referenced circuits.

The digital outputs have overload protection. They will resume normal operation when the overload is removed.

Table 2-39: Digital Output Specifications

Digital Output Specifications	Value
Maximum Voltage	24 V (26 V Maximum)
Maximum Sink/Source Current	250 mA/output
Output Saturation Voltage	0.9 V at maximum current
Output Resistance	3.7 Ω
Rise / Fall Time	250 μ s (2K pull up to 24V)
Reset State	Output Off (High Impedance State)

Table 2-40: Digital Output Pins on the Auxiliary I/O Connector

Pin#	Description	In/Out/Bi
7	Digital Output 0	Output
8	Digital Output 1	Output
9	Digital Output 2	Output
15	Digital Output Common	N/A
16	Digital Output 3	Output

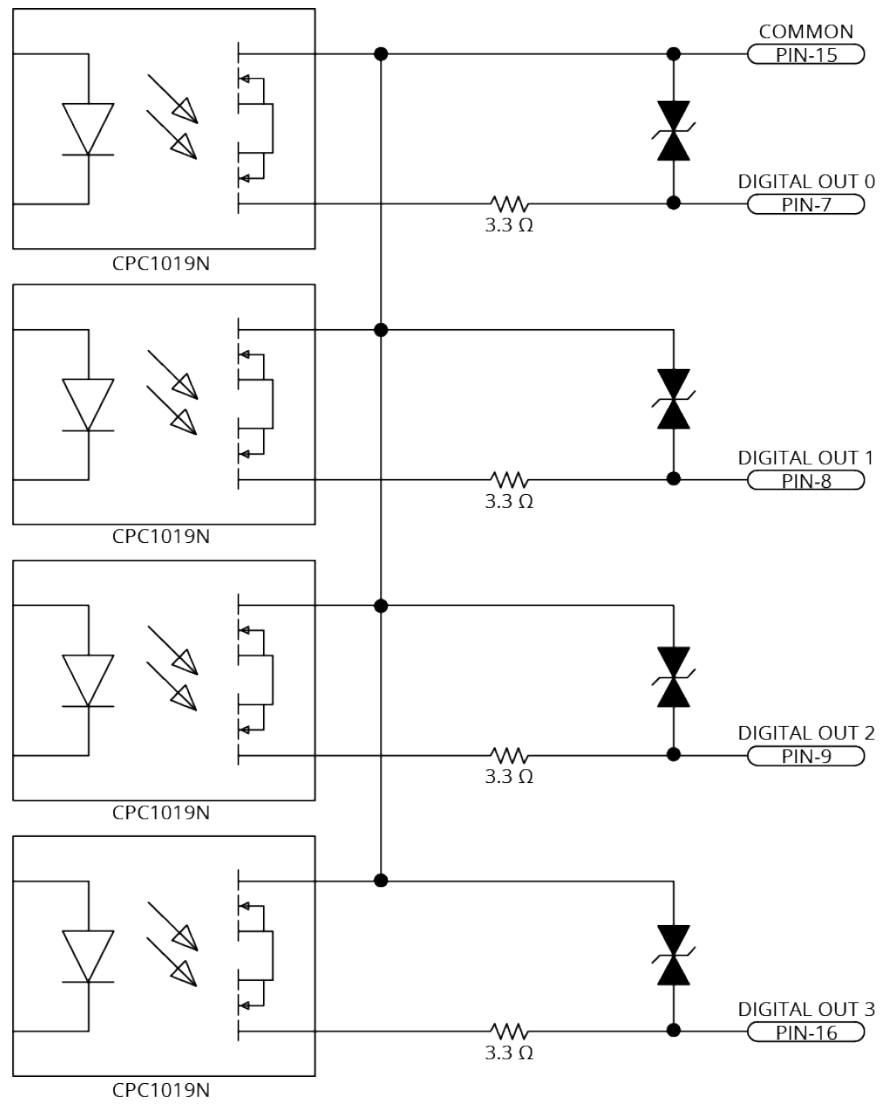


Figure 2-37: Digital Output Schematic (Aux I/O Connector)

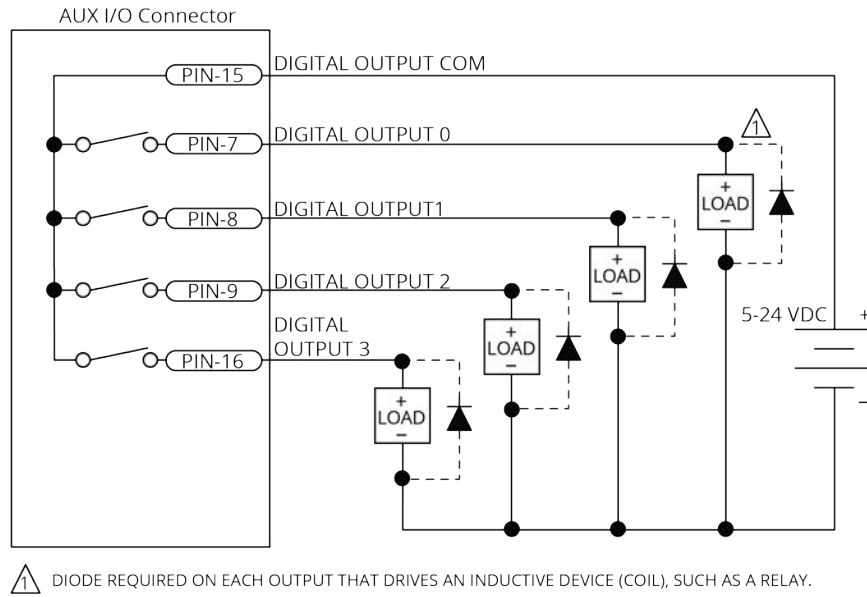


Figure 2-38: Digital Outputs Connected in Current Sourcing Mode

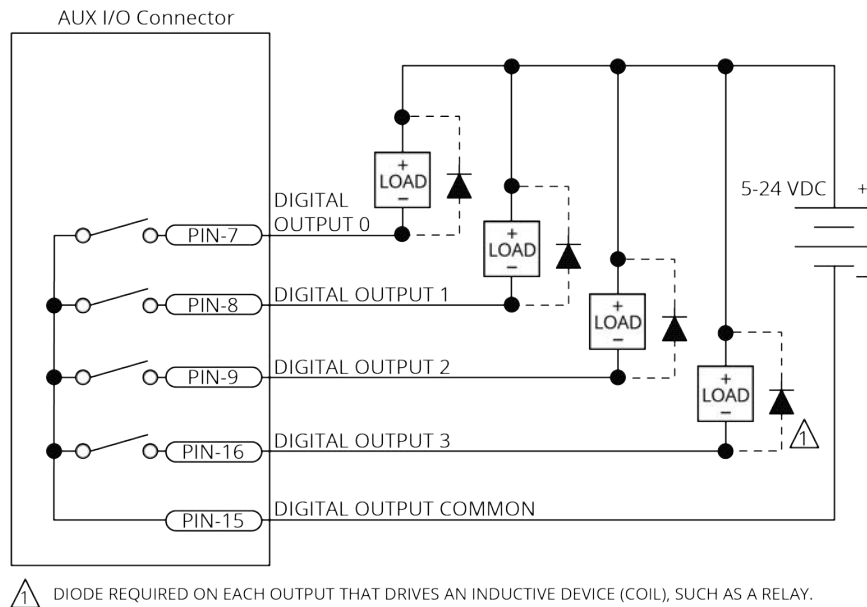


Figure 2-39: Digital Outputs Connected in Current Sinking Mode

2.5.4. Digital Inputs

You can connect the digital inputs to current sourcing or current sinking devices but you must connect all four inputs in the same configuration. Refer to Figure 2-42 and Figure 2-41. The digital inputs are not designed for high-voltage isolation applications. They should only be used with ground-referenced circuits.

Table 2-41: Digital Input Specifications

Input Voltage	Approximate Input Current	Turn On Time	Turn Off Time
+5 V to +24 V	6 mA	10 μ s	43 μ s

Table 2-42: Digital Input Pins on the Auxiliary I/O Connector

Pin#	Description	In/Out/Bi
17	Digital Input 0 / CCW EOT Input ⁽¹⁾	Input
18	Digital Input 1 / CW EOT Input ⁽¹⁾	Input
24	Digital Input Common	N/A
25	Digital Input 2 / Home Input ⁽¹⁾	Input
26	Digital Input 3	Input

(1) Software configured option

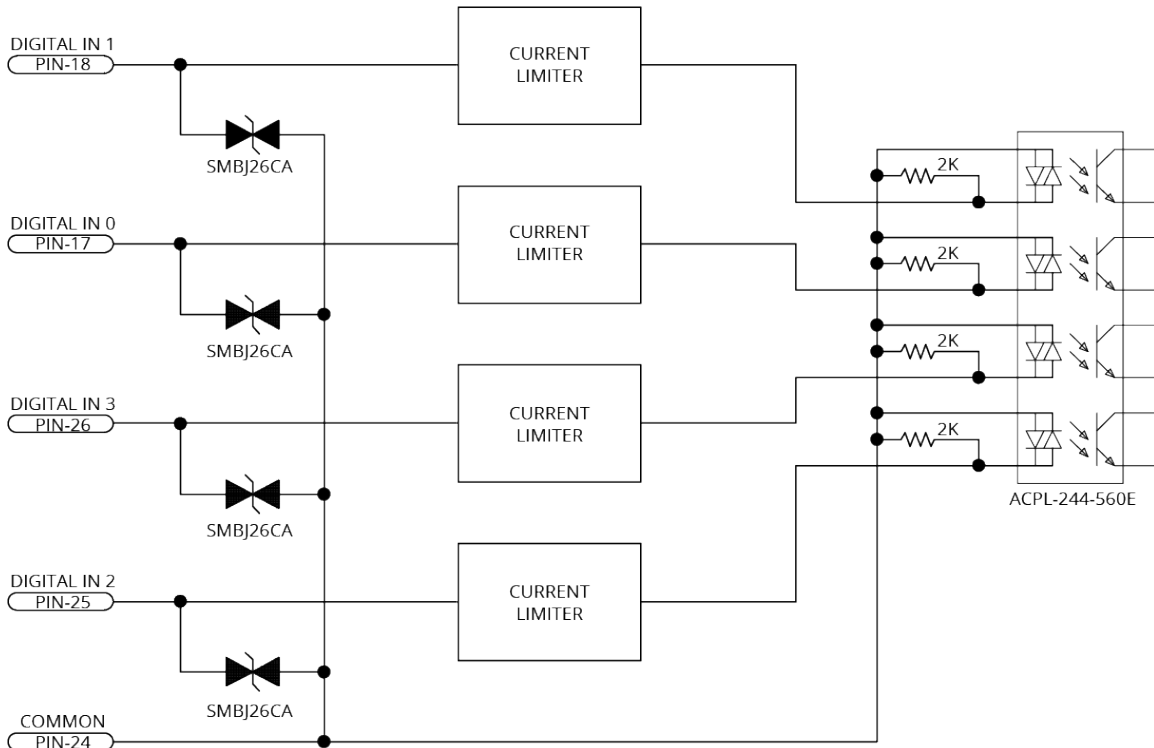


Figure 2-40: Digital Inputs Schematic (Aux I/O Connector)

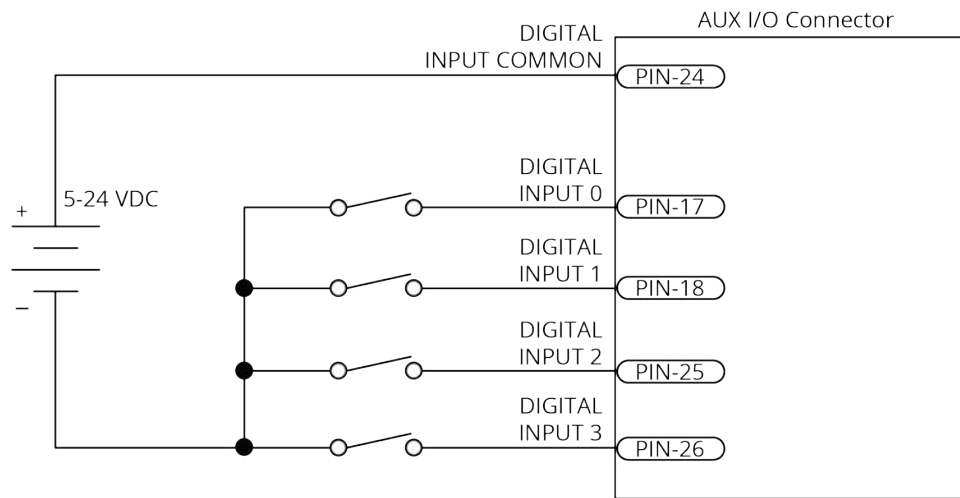


Figure 2-41: Digital Inputs Connected to Current Sinking Devices

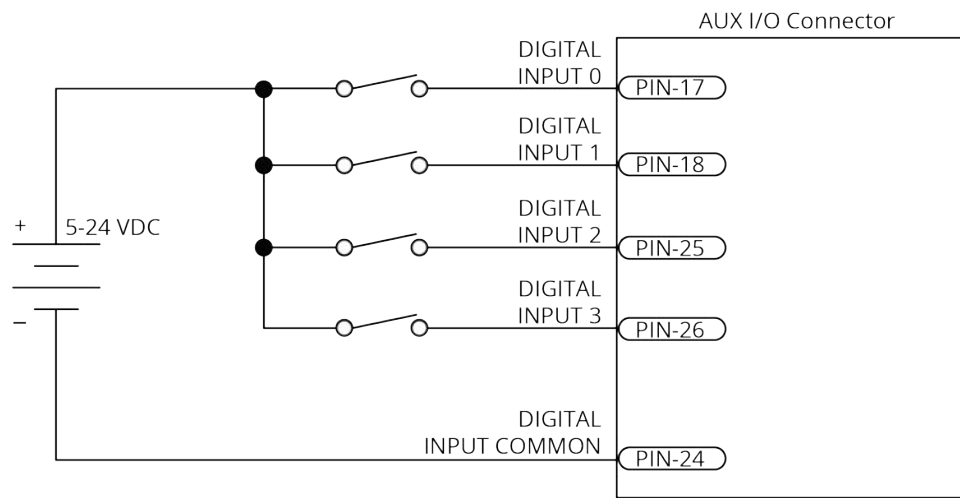


Figure 2-42: Digital Inputs Connected to Current Sourcing Devices

2.5.5. High-Speed Inputs

High-speed inputs 20 and 21 can be used as general purpose inputs or as the trigger signal for high speed data collection. Refer to the DriveDataCaptureConfigureTrigger() function [A3200: DATAACQ TRIGGER command] topic in the Help file for more information.

You can use the external PSO synchronization functions [A3200: PSOOUTPUT PULSE EXTSYNC command] to synchronize waveform generation with an external synchronization signal. When you activate this feature, the PSO Waveform module will not generate the configured waveform when an output event is received until the rising edge of the synchronization signal occurs.

Table 2-43: High-Speed Input Specifications

Specification	Value
Input Voltage	5V - 24 V input voltages
Input Current	10 mA
Input Device	HCPL-0630
Delay	50 nsec

Table 2-44: High-Speed Input Pins on the Auxiliary I/O Connector

Pin#	Description	In/Out/Bi
3	High-Speed Input 20 + / PSO External Sync. +	Input
4	High-Speed Input 20 - / PSO External Sync. -	Input
5	High-Speed Input 21 +	Input
6	High-Speed Input 21 -	Input

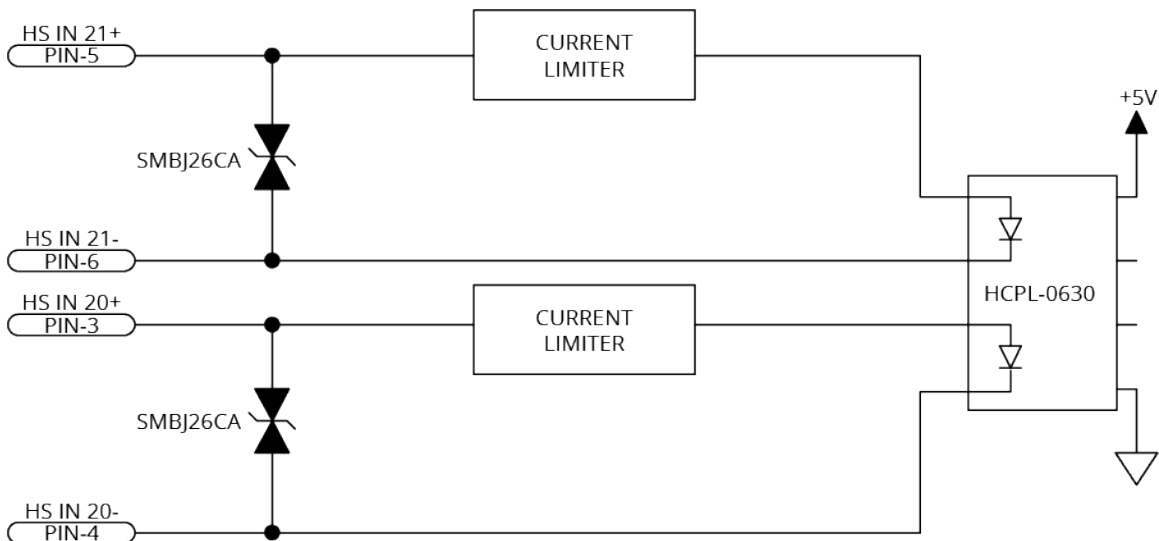


Figure 2-43: High-Speed Inputs

2.5.6. Analog Output 0

The analog output can be set from within a program or it can be configured to echo the state of select servo loop nodes.

The analog output is set to zero when you power on the system or reset the drive.

Table 2-45: Analog Output Specifications

Specification	Value
Output Voltage	-10 V to +10 V
Output Current	5 mA
Resolution (bits)	16 bits

Table 2-46: Analog Output Pins on the Auxiliary I/O Connector

Pin#	Description	In/Out/Bi
22	Analog Output 0	Output
23	Analog Common	N/A

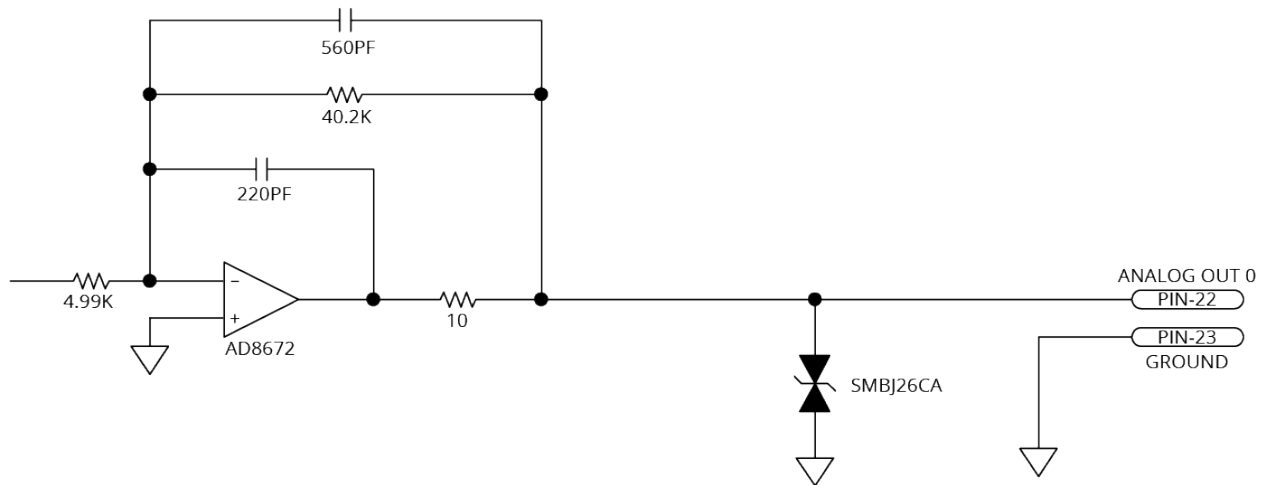


Figure 2-44: Analog Output 0 Schematic

2.5.7. Analog Input 0 (Differential)

To interface to a single-ended, non-differential voltage source, connect the signal common of the source to the negative input and connect the analog source signal to the positive input. A floating signal source must be referenced to the analog common. Refer to [Figure 2-45](#).

Table 2-47: Analog Input Specifications

Specification	Value
(AI+) - (AI-)	+10 V to -10 V ⁽¹⁾
Resolution (bits)	16 bits
Input Impedance	1 M Ω
1. Signals outside of this range may damage the input	

Table 2-48: Analog Input Pins on the Auxiliary I/O Connector

Pin#	Description	In/Out/Bi
13	Analog Input 0+ (Differential)	Input
14	Analog Input 0- (Differential)	Input
23	Analog Common	N/A

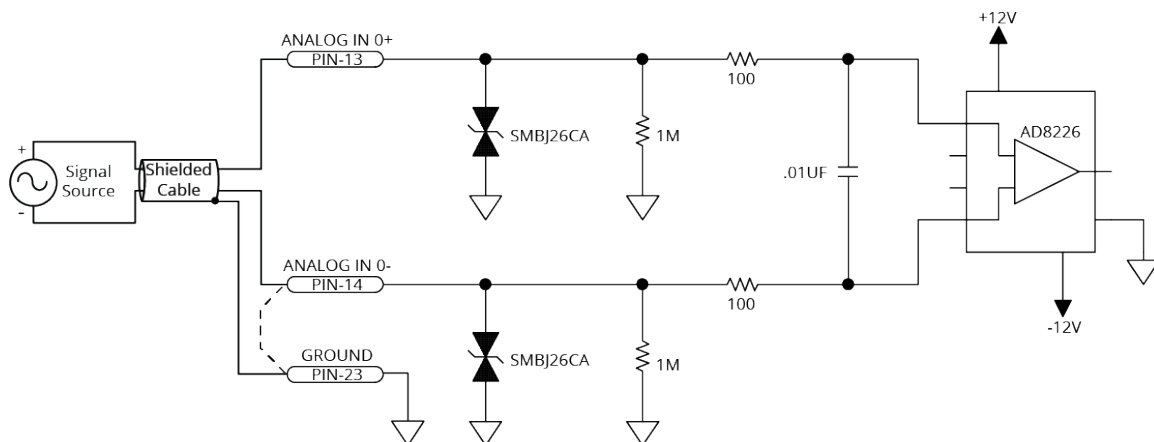


Figure 2-45: Analog Input 0 Schematic

2.6. Brake Power Supply Connector

This port is the power supply connection to the on-board brake control circuit. Refer to [Section 2.3.6](#) for more information about the brake output interface.

Table 2-49: Brake Power Supply Connector Pinout


Pin#	Description	In/Out/Bi	Connector
1	Brake Power Supply (+)	Input	
2	Brake Power Supply (-)	Input	

Table 2-50: Mating Connector Part Numbers for the Brake Power Supply Connector

Description	Aerotech P/N	Phoenix P/N	Tightening Torque (Nm)	Wire Size: AWG [mm ²]
2-Pin Terminal Block	ECK02390	1827616	0.22 - 0.25	0.14 - 1.5 [26-16]

2.7. HyperWire Interface

The HyperWire bus is the high-speed communications connection from the controller. It operates at 2 gigabits per second. The controller sends all command and configuration information through the HyperWire bus.

HyperWire cables can be safely connected to or disconnected from a HyperWire port while the PC and/or drive is powered on. However, any changes to the HyperWire network topology will disrupt communication and you must reset the controller to re-establish communication.



WARNING: Do not connect or disconnect HyperWire cables while you are loading firmware or damage to the drives may occur.

Table 2-51: HyperWire Card Part Number

Part Number	Description
HYPERWIRE-PCIE	HyperWire adapter, PCIe x4 interface

Table 2-52: HyperWire Cable Part Numbers

Part Number	Description
HYPERWIRE-AO10-5	HyperWire cable, active optical, 0.5 m
HYPERWIRE-AO10-10	HyperWire cable, active optical, 1.0 m
HYPERWIRE-AO10-30	HyperWire cable, active optical, 3.0 m
HYPERWIRE-AO10-50	HyperWire cable, active optical, 5.0 m
HYPERWIRE-AO10-200	HyperWire cable, active optical, 20.0 m

2.8. External Shunt Option [-SX1]



DANGER: The shunt resistor dissipates a high quantity of power. To prevent the danger of electric shock or fire, you must obey the precautions that follow:

- Correctly size, mount, and protect the external shunt resistor.
- Do not touch the shunt resistor terminals. There are lethal voltages on the terminals.
- Do not touch the surface of the drive or the external shunt resistor. The temperature can exceed 70°C.
- Restrict access to the shunt resistor while it is connected to a power source.

The -SX1 option provides a connection for a user-provided shunt resistor to dissipate excess energy and keep the internal drive voltage within safe levels. The drive switches this resistor "ON" when the internal bus voltage reaches approximately 380 VDC. This option is generally required for systems that have a large amount of stored mechanical energy that must be dissipated during deceleration.

Table 2-53: -SX1 Component Information

Component	Description	Aerotech P/N
Recommended Shunt Resistor	50 Ω (min), 300 W Vishay/Dale: RBEF030050R00KFBVT	ECR01039
1-Pin Mating Connector [QTY. 2]	Screw Torque Value: 0.6 - 0.8 N·m Wire Size: 0.2 - 6 mm ² [24-10 AWG] Phoenix: 0708250	ECK02452
F101 Fuse on the Control Board	8 A S.B.	EIF01022
Recommended Wire Size	16 AWG (1.3 mm ²) High Temperature	--

Equation 1:

Calculate the kinetic energy of the system. Any energy that is not lost to the system could be regenerated to the DC bus.

$$E_M = \left[\frac{1}{2} \right] [J_M + J_L] \omega_M^2 \quad \text{or} \quad E_M = \left[\frac{1}{2} \right] [M_M + M_L] v_M^2$$

(for rotary motors) (for linear motors)

J_M	rotor inertia (kg·m ²)
J_L	load inertia (kg·m ²)
ω_m	motor speed before deceleration (rad/s)
M_M	forcer mass (kg)
M_L	load mass (kg)
v_m	velocity (m/s)

Equation 2:

You will need a shunt resistor if the regenerated energy is greater than the Maximum Additional Storage Energy that the internal bus capacitor can store (Table 2-54).

$$E_{Ca} = \frac{1}{2} C (V_M^2 - V_{NOM}^2)$$

C	bus capacitor (F) [1,200 μF]
V_M	turn on voltage for shunt circuit (V) [380 V]
V_{NOM}	nominal bus voltage (V) [160 V or 320 V, Typical] [160 V or 320 V, Typical]

Table 2-54: Maximum Additional Storage Energy for a Standard XC4

Bus Voltage	Maximum Additional Energy
160 V	71.3 J
320 V	25.2 J

If a shunt resistor is required, calculate the value of resistance necessary to dissipate the energy.

Equations 3, 4, and 5:

Calculate the parameters of the shunt resistor.

Equation 3:

$$P_{PEAK} = \frac{E_M - E_{Ca}}{t_D}$$

P_{PEAK} peak power that the regeneration circuit must accommodate (W)

t_D deceleration time (s)

Equation 4:

$$P_{AV} = \frac{E_M - E_{Ca}}{t_{CYCLE}}$$

P_{AV} average power dissipated on shunt resistor (W)

t_{CYCLE} time between deceleration events (s)

Equation 5:

$$R = \frac{(2V_M - V_{HYS})^2}{4P_{PEAK}}$$

V_{HYS} hysteresis voltage of regeneration circuit (V) [10 V, Typical]

Additional useful equations:

1 lb·ft = 1.356 N·m

1 rad/s = 9.55 rpm

2.9. Sync Port

The Sync port is a bi-directional high speed proprietary interface that lets you transmit encoder signals between drives. This is typically used for multi-axis PSO applications where one or two drives send their encoder signals to a main drive that has the PSO logic and PSO output signal. The XC4 contains two Sync ports, labeled A and B.

To avoid signal contention, all Sync ports default to the input state during reset and immediately after power is applied to the drive.

Table 2-55: Sync-Related Functions

Function	Description
DriveEncoderOutputConfigureDivider(), DriveEncoderOutputConfigureInput(), DriveEncoderOutputOn(), DriveEncoderOutputOff() [A3200: ENCODER OUT command]	Configure each Sync port as an input or an output
PsoDistanceConfigureInputs() [A3200: PSOTRACK INPUT command]	Let the PSO to track the SYNC A or SYNC B port.
PsoWindowConfigureInput() [A3200: PSOWINDOW INPUT command]	

The Sync port uses low-voltage differential signaling (LVDS) and standard USB 3.0 type A (cross over) cables.

Table 2-56: Sync Port Cables

Part Number	Description
CBL-SYNC-3	Length 3 dm; Connectors: USB Type A to USB Type A
CBL-SYNC-5	Length 5 dm; Connectors: USB Type A to USB Type A
CBL-SYNC-7	Length 7 dm; Connectors: USB Type A to USB Type A
CBL-SYNC-10	Length 10 dm; Connectors: USB Type A to USB Type A

2.10. System Interconnection

Click on the image below to open a separate pdf window with a larger view of the drawing.

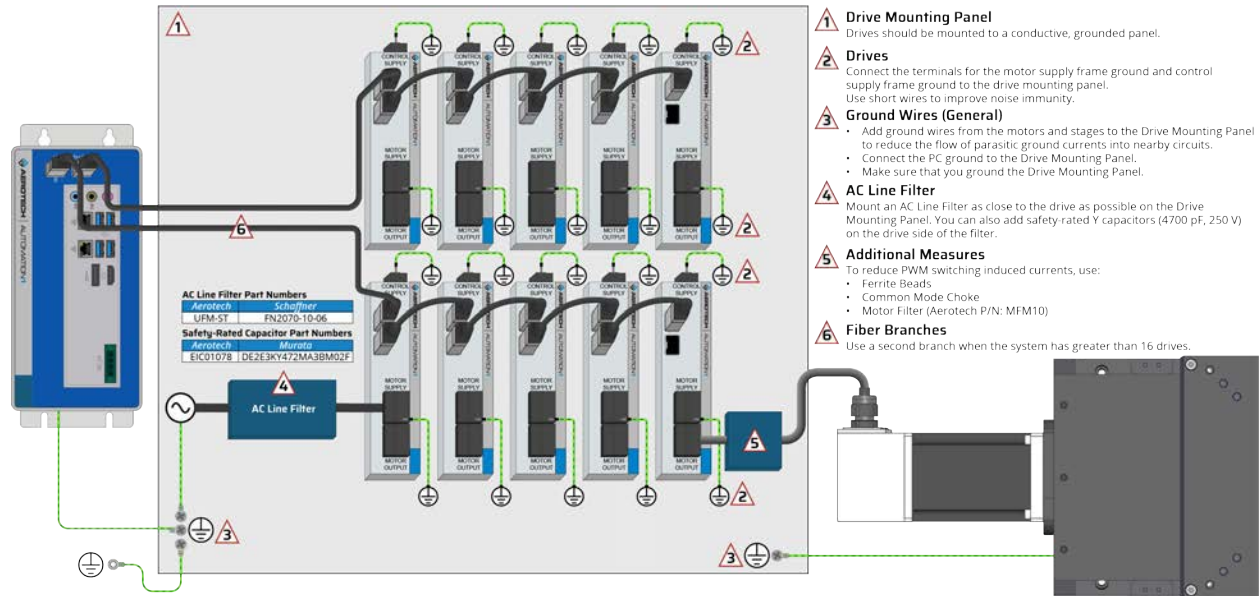
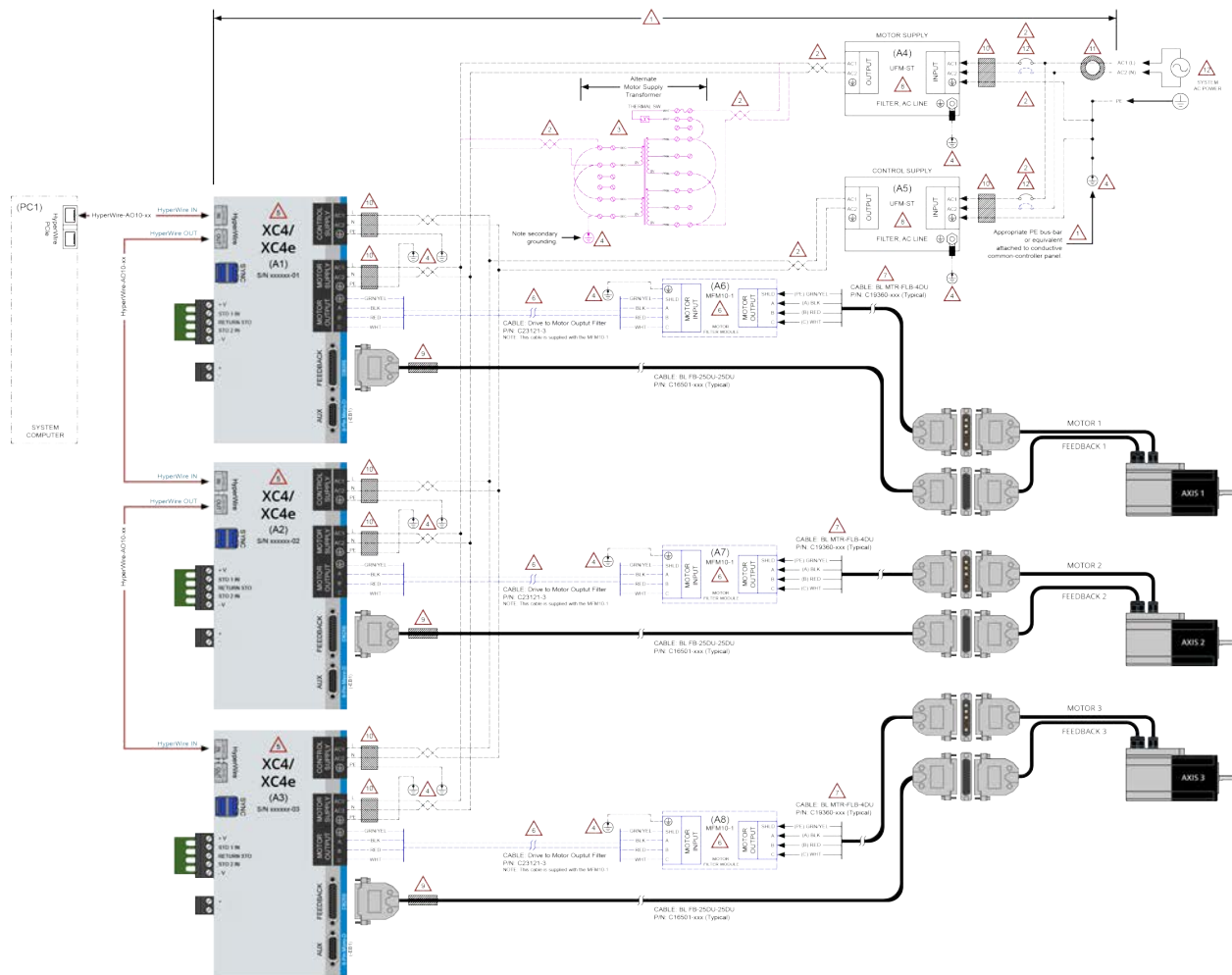


Figure 2-46: System Wiring Drawing (Best Practice)



<p>! ATTENTION !</p> <p>The system integrator or end user is responsible for all safety compliance and technical requirements for the system wiring.</p> <p>IMPORTANT: Read all parts of this manual before you install or operate the XL5e or before you do maintenance to your system.</p> <ul style="list-style-type: none"> To prevent injury to you and damage to the equipment, obey the precautions in this manual. If you do not understand the information in this manual, contact Aerotech Global Technical Support. <p>For EMC performance, mount all system components on to a common conductive metal panel.</p> <ul style="list-style-type: none"> Do not use a panel that has a painted or non-conductive coat applied. You can use a panel with a conductive surface coat. <p>Customer-supplied wiring</p> <ul style="list-style-type: none"> The system integrator is responsible for all safety compliance and technical requirements. Aerotech recommends that you use AC1 & AC2 twisted pair conductors with circuit runs as short as possible. When routing conductors, keep high-voltage supply wiring separated from low-voltage I/O or control/feedback signal wiring. 	<p>Alternate Motor Supply transformer (for reference only)</p> <p>System Protective Earth (PE) grounds</p> <ul style="list-style-type: none"> Keep PE wires as short as possible Each PE wire should have a dedicated attachment/termination point Aerotech recommends that you should terminate each PE directly to the grounded component panel. Refer to Note 1 above. <p>XC4 and XC4e Controllers</p> <ul style="list-style-type: none"> Refer to assemblies (A1), (A2), and (A3) If the controllers were purchased as an integrated system, refer to the System Interconnections drawing included with the system documentation. Note that a controller's serial number is specific to an assigned axis. <p>OPTIONAL EQUIPMENT: MFM10-1 Motor Filter Module with 10ARMS Cable</p> <ul style="list-style-type: none"> Refer to assemblies (A6), (A7), and (A8) For mechanical and electrical descriptions of the MFM10-1, refer to the Motor Filter Module Hardware Manual (MFM10.pdf) at http://www.aerotechmotorcontrol.com/manuals/index.aspx. Find the manual under the Controller Accessories dropdown. <p>If the MFM10-1 is not used, connect the system motor cable directly to the controller MOTOR OUTPUT terminals.</p>	<p>UFM-ST Filter, AC Line Enclosure</p> <ul style="list-style-type: none"> Refer to assemblies (A4) and (A5) For mechanical and electrical descriptions of the UFM-ST, refer to the UFM-ST Hardware Manual (UFMST.pdf) at http://www.aerotechmotorcontrol.com/manuals/index.aspx. Find the manual under the Controller Accessories dropdown. <p>Axis FEEDBACK Cable Ferrite EMC Filters</p> <ul style="list-style-type: none"> Part No. 4044616201 (Aerotech # EC202346) Clamp-On Construction Apply as close as possible to the FEEDBACK connector as illustrated <p>XC4e Controller Control Power and Motor Power -and- UFM-ST Ferrite EMC Filters</p> <ul style="list-style-type: none"> Part No. 4044616201 (Aerotech # EC202347) Clamp-On Construction Apply as close as possible to the power connector as illustrated <p>System AC Supply Ferrite EMC Filter</p> <ul style="list-style-type: none"> Part No. Laird RLF360230-300 (Aerotech # EC202396) Toroid-Ring Construction Loop System AC1 and AC2 conductor pair two times through the toroid <p>System AC Power</p> <ul style="list-style-type: none"> If AC2 is not referenced to NEUTRAL, the AC2 line must have a fuse or circuit breaker protection <p>The information on this page is for reference only and represents best practice applications.</p>
---	---	--

Figure 2-47: PC-Based Controller System Interconnection (Best Practice)

2.11. PC Configuration and Operation Information

For more information about hardware requirements, PC configuration, programming, system operation, and utilities, refer to the Help file.

This page intentionally left blank.

Chapter 3: -EB1 I/O Option Board

The -EB1 I/O option board has 16 digital inputs, 16 digital outputs, 3 analog inputs, 3 analog outputs, and PSO outputs.

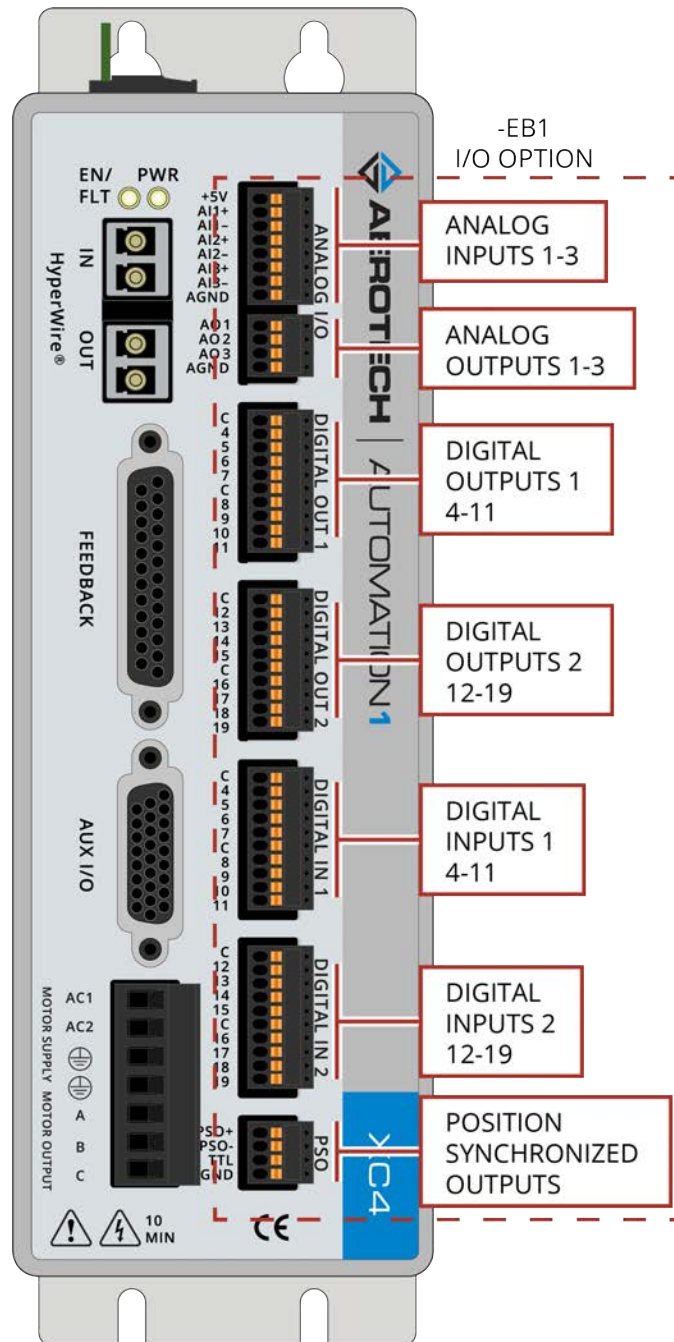


Figure 3-1: XC4 with -EB1 I/O Option Board Connectors

3.1. Digital Outputs [-EB1]

Optically-isolated solid-state relays drive the digital outputs. You can connect the digital outputs in current sourcing or current sinking mode but you must connect all four outputs in a port in the same configuration. Refer to [Figure 3-3](#) and [Figure 3-4](#).

The digital outputs are not designed for high-voltage isolation applications and they should only be used with ground-referenced circuits.

You must install suppression diodes on digital outputs that drive relays or other inductive devices. To see an example of a current sourcing output that has diode suppression, refer to [Figure 3-3](#). To see an example of a current sinking output that has diode suppression, refer to [Figure 3-4](#).

The digital outputs have overload protection. They will resume normal operation when the overload is removed.

Table 3-1: Digital Output Specifications [-EB1]

Digital Output Specifications	Value
Maximum Voltage	24 V (26 V Maximum)
Maximum Sink/Source Current	250 mA/output
Output Saturation Voltage	0.9 V at maximum current
Output Resistance	3.7 Ω
Rise / Fall Time	250 μ s (2K pull up to 24V)
Reset State	Output Off (High Impedance State)

Table 3-2: Digital Output 1 Connector Pinout [-EB1]

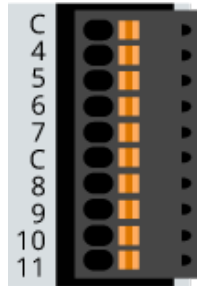
Pin#	Description	In/Out/Bi	Connector
1	Output Common for Outputs 4-7	N/A	
2	Output 4 (Optically-Isolated)	Output	
3	Output 5 (Optically-Isolated)	Output	
4	Output 6 (Optically-Isolated)	Output	
5	Output 7 (Optically-Isolated)	Output	
6	Output Common for Outputs 8-11	N/A	
7	Output 8 (Optically-Isolated)	Output	
8	Output 9 (Optically-Isolated)	Output	
9	Output 10 (Optically-Isolated)	Output	
10	Output 11 (Optically-Isolated)	Output	

Table 3-3: Mating Connector Part Numbers for the Digital Output 1 Connector [-EB1]

Mating Connector	Aerotech P/N	Third Party P/N	Wire Size: mm ² [AWG]
10-Pin Terminal Block	ECK02395	Phoenix 1700841	0.5 - 0.14 [20-26]

Table 3-4: Digital Output 2 Connector Pinout [-EB1]

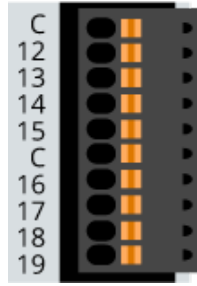
Pin#	Description	In/Out/Bi	Connector
1	Output Common for Outputs 12-15	N/A	
2	Output 12 (Optically-Isolated)	Output	
3	Output 13 (Optically-Isolated)	Output	
4	Output 14 (Optically-Isolated)	Output	
5	Output 15 (Optically-Isolated)	Output	
6	Output Common for Outputs 16-19	N/A	
7	Output 16 (Optically-Isolated)	Output	
8	Output 17 (Optically-Isolated)	Output	
9	Output 18 (Optically-Isolated)	Output	
10	Output 19 (Optically-Isolated)	Output	

Table 3-5: Mating Connector Part Numbers for the Digital Output 2 Connector [-EB1]

Mating Connector	Aerotech P/N	Third Party P/N	Wire Size: mm ² [AWG]
10-Pin Terminal Block	ECK02395	Phoenix 1700841	0.5 - 0.14 [20-26]

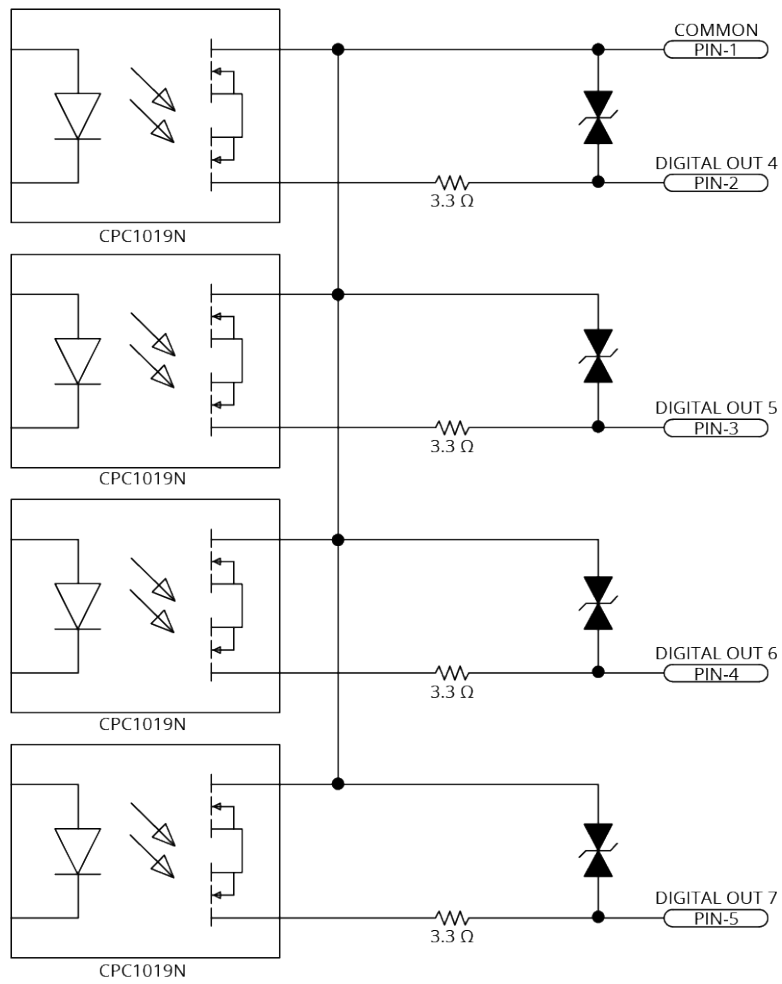
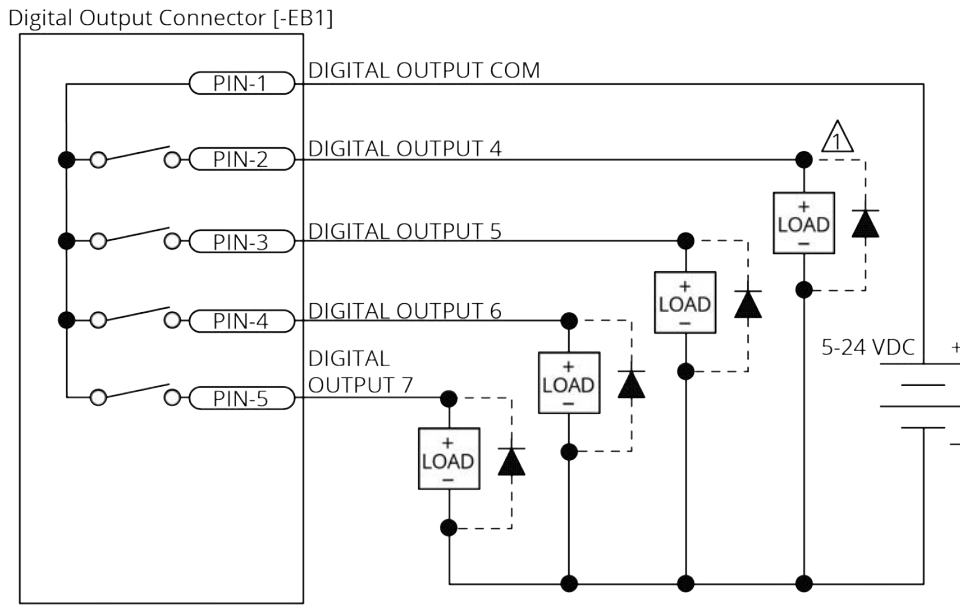
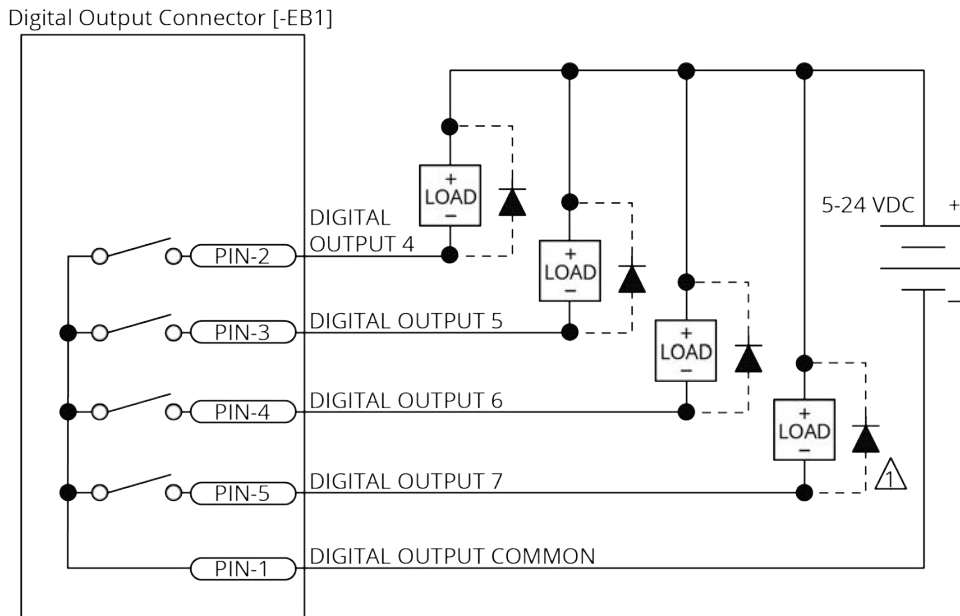


Figure 3-2: Digital Outputs Schematic [-EB1]



DIODE REQUIRED ON EACH OUTPUT THAT DRIVES AN INDUCTIVE DEVICE (COIL), SUCH AS A RELAY.

Figure 3-3: Digital Outputs Connected in Current Sourcing Mode [-EB1]



DIODE REQUIRED ON EACH OUTPUT THAT DRIVES AN INDUCTIVE DEVICE (COIL), SUCH AS A RELAY.

Figure 3-4: Digital Outputs Connected in Current Sinking Mode [-EB1]

3.2. Digital Inputs [-EB1]

Input bits are arranged in groups of 4 and each group shares a common pin. This lets a group be connected to current sourcing or current sinking devices, based on the connection of the common pin in that group.

To be able to connect an input group to current sourcing devices, connect the input group's common pin to the power supply return (-). Refer to [Figure 3-6](#).

To be able to connect an input group to current sinking devices, connect the input group's common pin to the power supply source (+). Refer to [Figure 3-7](#).

The digital inputs are not designed for high-voltage isolation applications. They should only be used with ground-referenced circuits.

Table 3-6: Digital Input Specifications [-EB1]

Input Voltage	Approximate Input Current	Turn On Time	Turn Off Time
+5 V to +24 V	6 mA	10 μ s	43 μ s

Table 3-7: Digital Input 1 Connector Pinout [-EB1]

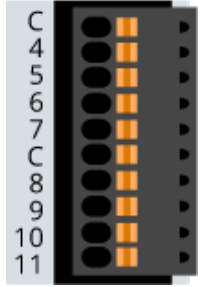
Pin#	Description	In/Out/Bi	Connector
1	Input Common for Inputs 4-7	N/A	
2	Input 4 (Optically-Isolated)	Input	
3	Input 5 (Optically-Isolated)	Input	
4	Input 6 (Optically-Isolated)	Input	
5	Input 7 (Optically-Isolated)	Input	
6	Input Common for Inputs 8-11	N/A	
7	Input 8 (Optically-Isolated)	Input	
8	Input 9 (Optically-Isolated)	Input	
9	Input 10 (Optically-Isolated)	Input	
10	Input 11 (Optically-Isolated)	Input	

Table 3-8: Mating Connector Part Numbers for the Digital Input 1 Connector [-EB1]

Mating Connector	Aerotech P/N	Third Party P/N	Wire Size: mm ² [AWG]
10-Pin Terminal Block	ECK02395	Phoenix 1700841	0.5 - 0.14 [20-26]

Table 3-9: Digital Input 2 Connector Pinout [-EB1]

Pin#	Description	In/Out/Bi	Connector
1	Input Common for Inputs 12-15	N/A	
2	Input 12 (Optically-Isolated)	Input	
3	Input 13 (Optically-Isolated)	Input	
4	Input 14 (Optically-Isolated)	Input	
5	Input 15 (Optically-Isolated)	Input	
6	Input Common for Inputs 16-19	N/A	
7	Input 16 (Optically-Isolated)	Input	
8	Input 17 (Optically-Isolated)	Input	
9	Input 18 (Optically-Isolated)	Input	
10	Input 19 (Optically-Isolated)	Input	

Table 3-10: Mating Connector Part Numbers for the Digital Input 2 Connector [-EB1]

Mating Connector	Aerotech P/N	Third Party P/N	Wire Size: mm ² [AWG]
10-Pin Terminal Block	ECK02395	Phoenix 1700841	0.5 - 0.14 [20-26]

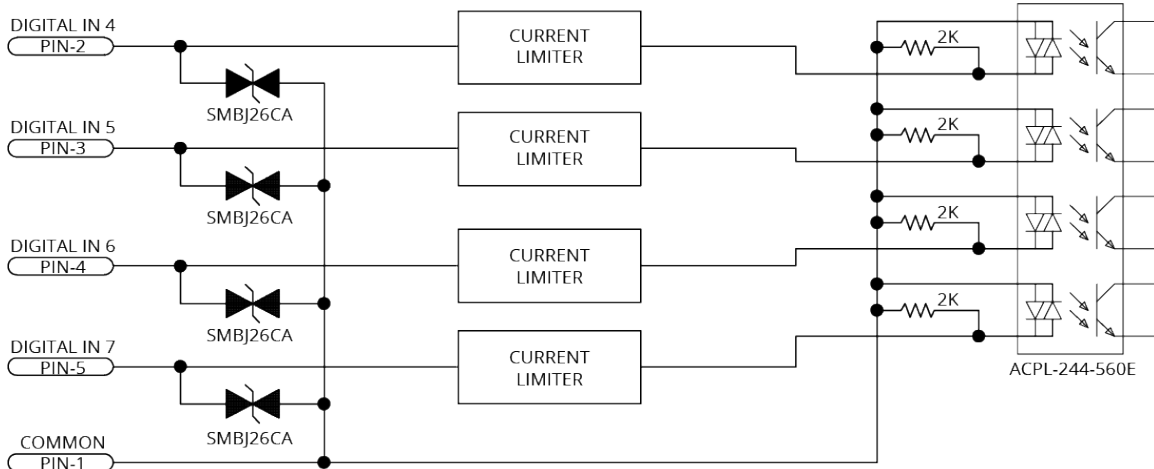


Figure 3-5: Digital Inputs Schematic [-EB1]



IMPORTANT: Each bank of four inputs must be connected in an all sourcing or all sinking configuration.

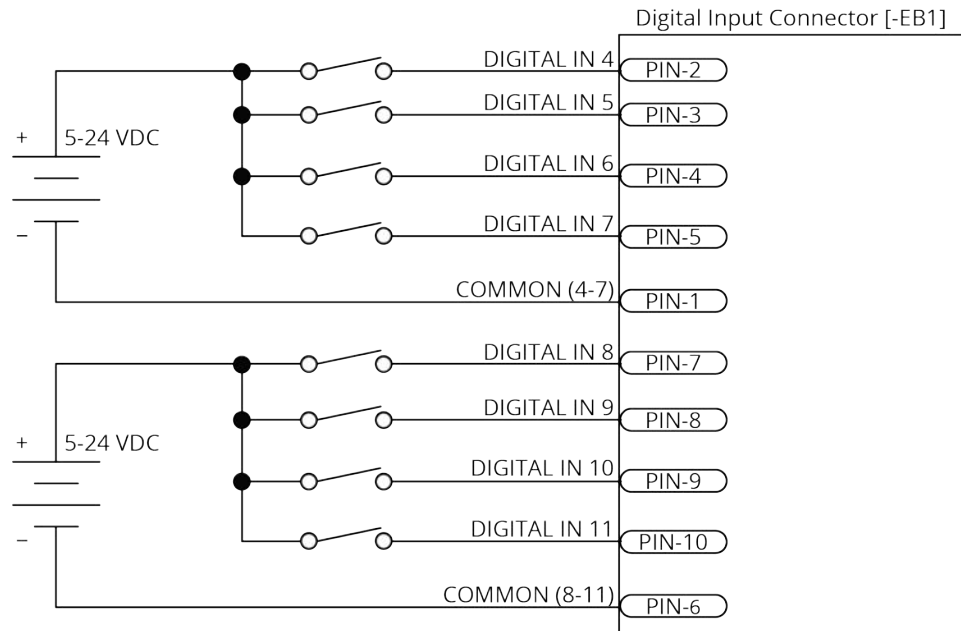


Figure 3-6: Digital Inputs Connected to Current Sourcing (PNP) Devices [-EB1]

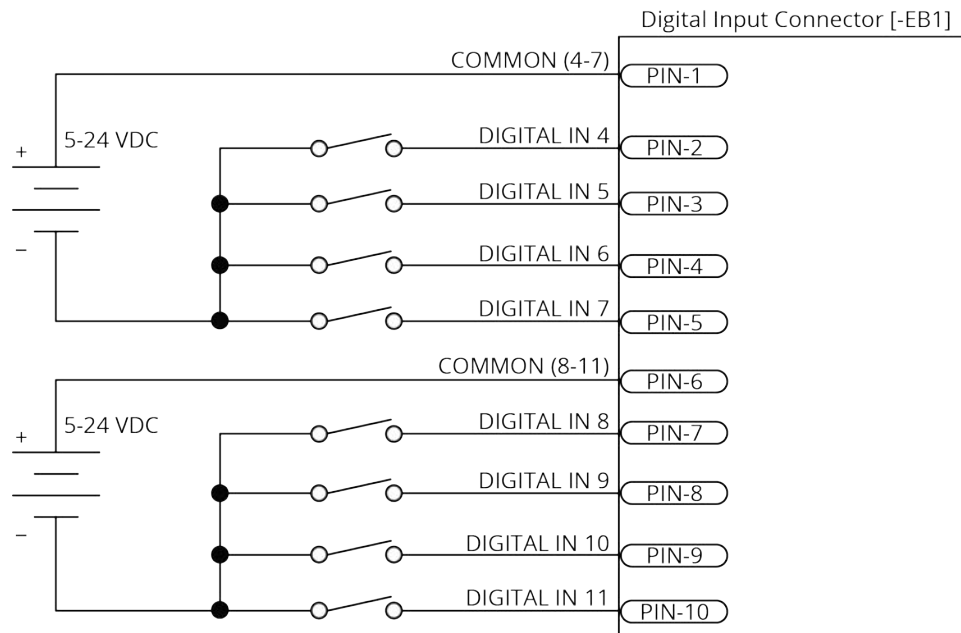


Figure 3-7: Digital Inputs Connected to Current Sinking (NPN) Devices [-EB1]

3.3. Analog Outputs [-EB1]

The analog output can be set from within a program or it can be configured to echo the state of select servo loop nodes.

The analog output is set to zero when you power on the system or reset the drive.

Table 3-11: Analog Output Specifications [-EB1]

Specification	Value
Output Voltage	-10 V to +10 V
Output Current	5 mA
Resolution (bits)	16 bits

Table 3-12: Analog Output Connector Pinout [-EB1]


Pin #	Description	In/Out/Bi	Connector
1	Analog Output 1	Output	
2	Analog Output 2	Output	
3	Analog Output 3	Output	
4	Ground	N/A	

Table 3-13: Mating Connector Part Numbers for the Analog Output Connector [-EB1]

Type	Aerotech P/N	Third Party P/N	Wire Size: mm ² [AWG]
4-Pin Terminal Block	ECK02399	Phoenix 1768004	0.5- 0.14 [20-26]

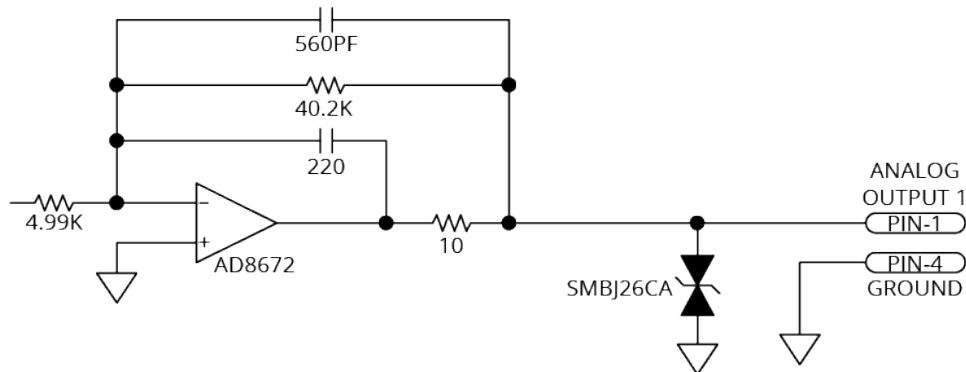


Figure 3-8: Analog Output Typical Connection [-EB1]

3.4. Analog Inputs [-EB1]

To interface to a single-ended, non-differential voltage source, connect the signal common of the source to the negative input and connect the analog source signal to the positive input. A floating signal source must be referenced to the analog common. Refer to [Figure 3-9](#).

Table 3-14: Differential Analog Input Specifications [-EB1]

Specification	Value
(AI+) - (AI-)	+10 V to -10 V ⁽¹⁾
Resolution (bits)	16 bits
Input Impedance	1 MΩ
1. Signals outside of this range may damage the input	

Table 3-15: Analog Input Connector Pinout [-EB1]

Pin#	Description	In/Out/Bi	Connector
1	+5V (250 mA max)	N/A	
2	Analog Input 1+	Input	
3	Analog Input 1-	Input	
4	Analog Input 2+	Input	
5	Analog Input 2-	Input	
6	Analog Input 3+	Input	
7	Analog Input 3-	Input	
8	Ground	N/A	

Table 3-16: Mating Connector Part Numbers for the Analog Input Connector [-EB1]

Mating Connector	Aerotech P/N	Third Party P/N	Wire Size: mm ² [AWG]
8-Pin Terminal Block	ECK02397	Phoenix 1908101	0.5 - 0.14 [20-26]

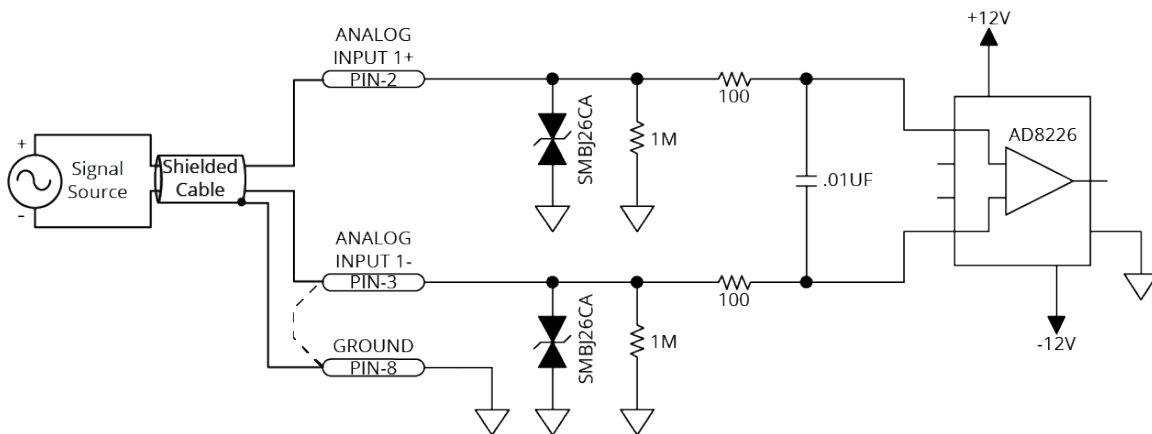


Figure 3-9: Analog Input Typical Connection [-EB1]

3.5. Position Synchronized Output Interface [-EB1]

The PSO output signal is available on the -EB1 option board in two signal formats: TTL and Isolated.

The PSO signal is also available on the AUX I/O connector. Refer to [Section 2.5.2](#).

You cannot use a sine wave encoder with the -MX1 multiplier option as an input to the PSO. The -MX1 option does not generate emulated quadrature signals.

Table 3-17: PSO Specifications [-EB1]

Specification		Value
Output	TTL	5 V, 50 mA (max)
	Isolated	5-24 V, 250 mA
Maximum PSO Output (Fire) Frequency	TTL	12.5 MHz
	Isolated	5 MHz
Output Latency [Fire event to output change]	TTL	5 ns
	Isolated	150 ns

Table 3-18: PSO Interface Connector Pinout [-EB1]

Pin #	Description	In/Out/Bi	Connector
1	PSO Output+	Output	
2	PSO Output-	Output	
3	PSO Output (TTL)	Output	
4	Ground	N/A	

Table 3-19: Mating Connector Part Numbers for the PSO Interface Connector [-EB1]

Type	Aerotech P/N	Third Party P/N	Wire Size: mm ² [AWG]
4-Pin Terminal Block	ECK02399	Phoenix 1768004	0.5- 0.14 [20-26]

Isolated Signals

This output signal is a fully-isolated 5-24V compatible output capable of sourcing or sinking current. This output is normally open and only conducts current when a PSO fire event occurs.

The PSO Isolated Outputs are overload protected and will turn off if the maximum output current is exceeded.

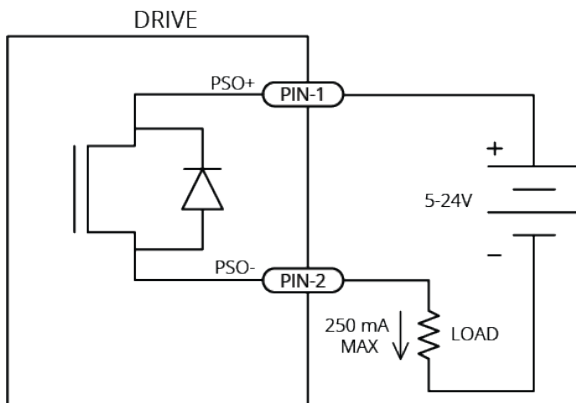


Figure 3-10: PSO Output Sources Current

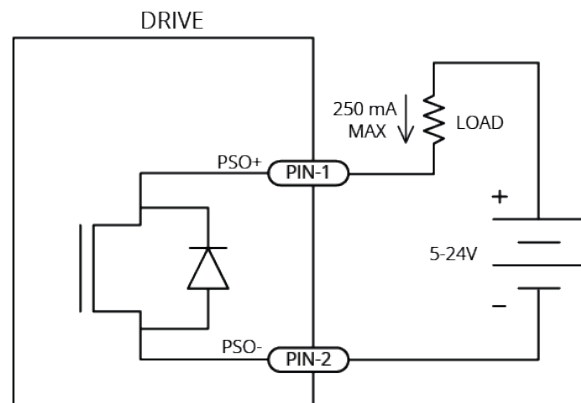


Figure 3-11: PSO Output Sinks Current

TTL Signals

This output signal is a 5V TTL signal which is used to drive an opto coupler or general purpose TTL input. This signal is active high and is driven to 5V when a PSO fire event occurs.

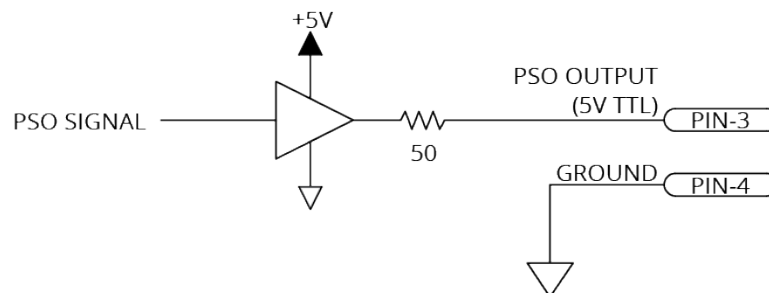


Figure 3-12: PSO TTL Outputs Schematic

Chapter 4: Cables and Accessories



IMPORTANT: Find Aerotech cable drawings on the website at <http://www.aerotechmotioncontrol.com/manuals/index.aspx>.

Table 4-1: Standard Interconnection Cables

Cable Part #	Description
Joystick	See Section 4.1 .
ECZ01231	BBA32 Interconnect Cable

4.1. Joystick Interface

Aerotech Multi-Axis Joystick (NEMA12 (IP54) rated) is powered from 5 V and has a nominal 2.5 V output in the center detent position. Three buttons are used to select axis pairs and speed ranges. An optional interlock signal is used to indicate to the controller that the joystick is present. Joystick control will not activate unless the joystick is in the center location. Third party devices can be used provided they produce a symmetric output voltage within the range of -10 V to +10 V.

Connecting joystick with an Aerotech cable, all Aerotech cables are labeled to identify the connector and connections. The joystick parameters must be set to match the analog and digital I/O connections.

The following drawings illustrate how to connect a single- or two-axis joystick. Refer to the Help file for programming information about how to change joystick parameters.

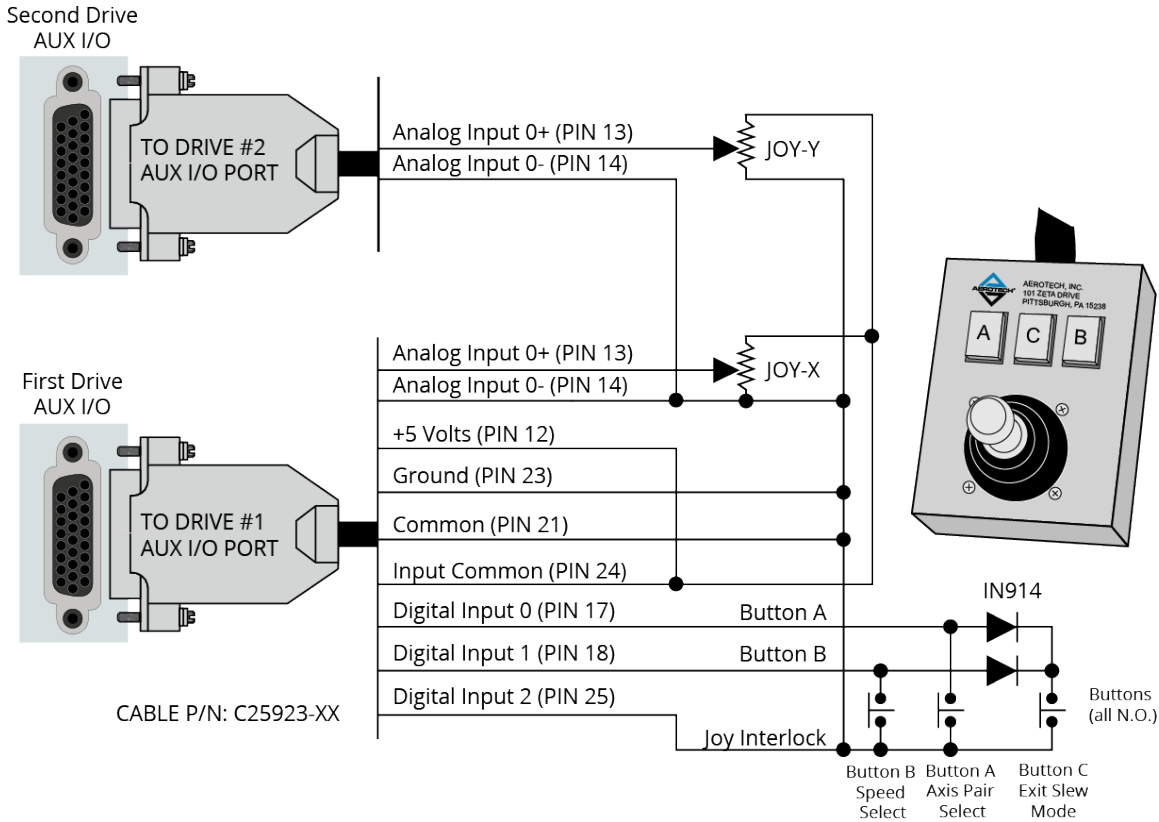


Figure 4-1: Two Axis Joystick Interface (to the Aux I/O of two drives)

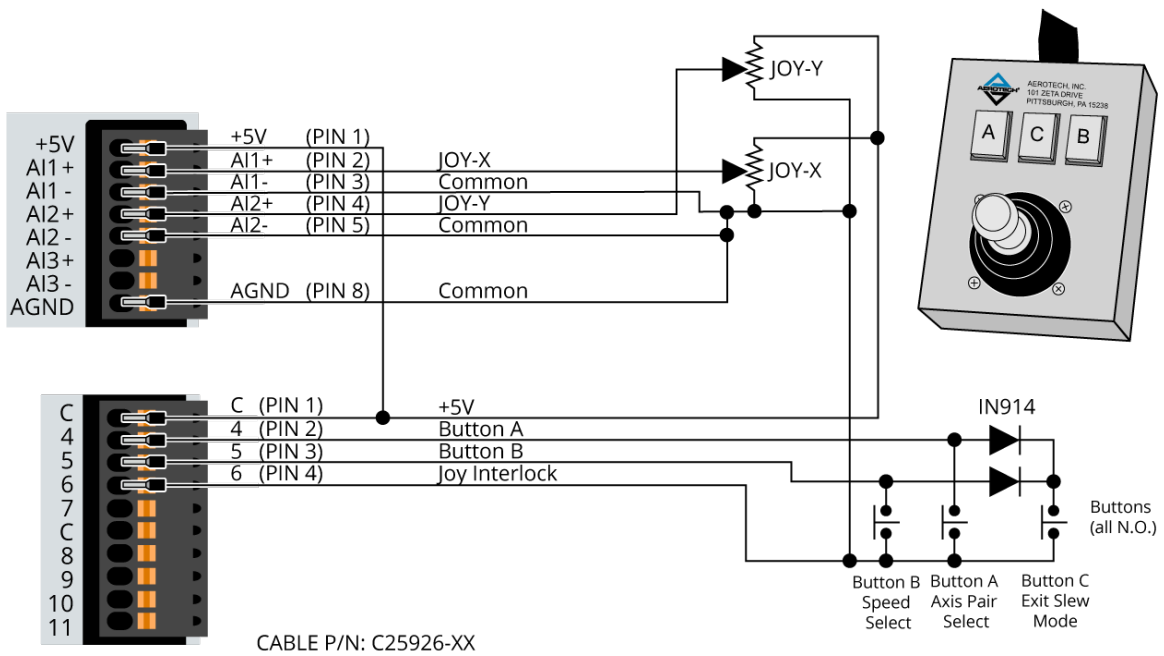


Figure 4-2: Two Axis Joystick Interface (to the I/O board)

4.2. Handwheel Interface

A handwheel can be used to manually control axis position. The handwheel must provide 5V differential quadrature signals to the XC4



IMPORTANT: You can find instructions on how to enable the handwheel in the Help file.

Connect a handwheel to the Aux I/O as shown in Figure 4-3 or Figure 4-4.

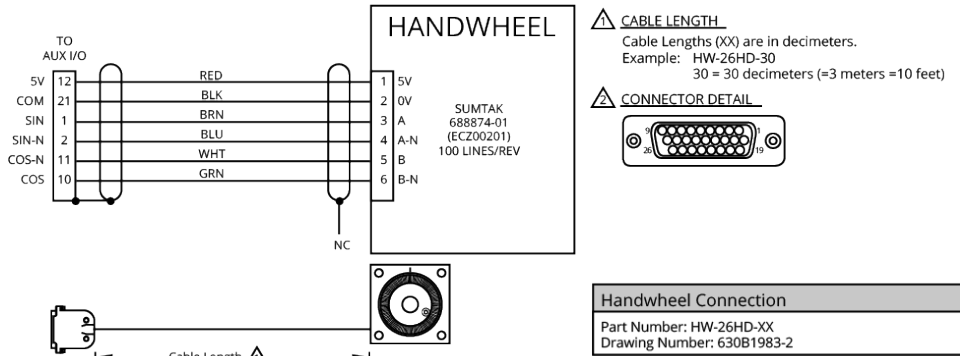


Figure 4-3: Handwheel Interconnection to Aux I/O Connector

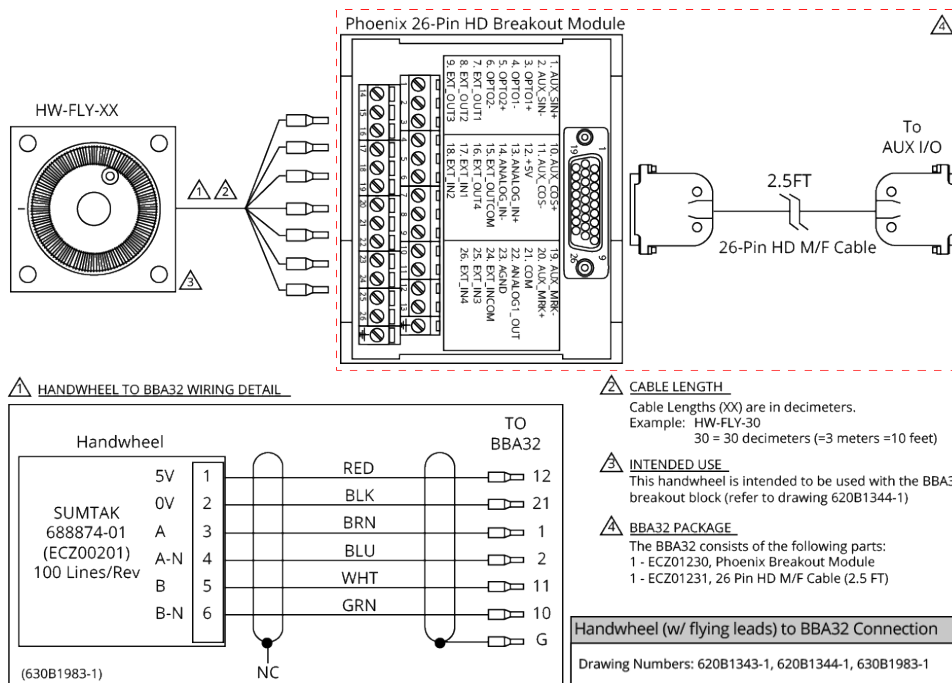


Figure 4-4: Handwheel Interconnection to the Aux I/O through a BBA32 Module

Chapter 5: Maintenance



IMPORTANT: For your own safety and for the safety of the equipment:

- Do not remove the cover of the XC4
- Do not attempt to access the internal components.

A fuse that needs to be replaced indicates that there is a more serious problem with the system or setup. Contact Global Technical Support for assistance.



DANGER: If you must remove the covers and access any internal components be aware of the risk of electric shock.

1. Disconnect the Mains power connection.
2. Wait at least ten (10) minutes after removing the power supply before doing maintenance or an inspection. Otherwise, there is the danger of electric shock.
3. All tests must be done by an approved service technician. Voltages inside the controller and at the input and output power connections can kill you.

Table 5-1: LED Description

LED	Color	Description
PWR	GREEN	The light will illuminate and remain illuminated while power is applied.
EN/FLT	GREEN	The axis is Enabled.
	RED	The axis is in a Fault Condition.
	GREEN/RED (alternates)	The axis is Enabled in a Fault Condition. or The light is configured to blink for setup.

Table 5-2: Troubleshooting

Symptom	Possible Cause and Solution
No Communication	Make sure the power LED is illuminated (this indicates that power is present).
	Make sure that all communication cables (HyperWire, for example) are fully inserted in their ports.

5.1. Preventative Maintenance

Do an inspection of the XC4 and the external wiring one time each month. It might be necessary to do more frequent inspections based on:

- The operating conditions of the system.
- How you use the system.

Table 5-3: Preventative Maintenance

Check	Action to be Taken
Examine the chassis for hardware and parts that are damaged or loose. It is not necessary to do an internal inspection unless you think internal damage occurred.	Repair all damaged parts.
Do an inspection of the cooling vents.	Remove all material that collected in the vents.
Examine the work area to make sure there are no fluids and no electrically conductive materials.	Do not let fluids and electrically conductive material go into the XC4.
Examine all cables and connections to make sure they are correct.	Make sure that all connections are correctly attached and not loose. Replace cables that are worn. Replace all broken connectors.

Cleaning



DANGER: Before you clean the XC4, disconnect the electrical power from the drive.

Use a clean, dry, soft cloth to clean the chassis of the XC4. If necessary, you can use a cloth that is moist with water or isopropyl alcohol. If you use a moist cloth, make sure that moisture does not go into the XC4. Also make sure that it does not go onto the outer connectors and components.

Do not use fluids and sprays to clean the XC4 because they can easily go into the chassis or onto the outer connectors and components. If a cleaning solution goes into the XC4, internal contamination can cause corrosion and electrical short circuits.

Do not clean the labels with a cleaning solution because it might remove the label information.

5.2. Fuse Specifications



WARNING: Replace fuses only with the same type and value.

Table 5-4: Control Board Fuse Specifications

Fuse	Description	Size	Aerotech P/N	Third Party P/N
F100	Control Power at Line Input (L)	2 A S.B.	EIF01044	Littelfuse 0877002.MXEP
F101	-SX1 (External Shunt) Option	8 A S.B.	EIF01022	Littelfuse 0215008.HXP
F102	Motor Bus Supply at AC1 XC4-10)	5 A S.B.	EIF01023	Littelfuse 215005.HXP
	Motor Bus Supply at AC1 XC4-20/-30)	10 A S.B.	EIF01020	Littelfuse 0215010.HXP

This page intentionally left blank.

Appendix A: Warranty and Field Service

Aerotech, Inc. warrants its products to be free from harmful defects caused by faulty materials or poor workmanship for a minimum period of one year from date of shipment from Aerotech. Aerotech's liability is limited to replacing, repairing or issuing credit, at its option, for any products that are returned by the original purchaser during the warranty period. Aerotech makes no warranty that its products are fit for the use or purpose to which they may be put by the buyer, whether or not such use or purpose has been disclosed to Aerotech in specifications or drawings previously or subsequently provided, or whether or not Aerotech's products are specifically designed and/or manufactured for buyer's use or purpose. Aerotech's liability on any claim for loss or damage arising out of the sale, resale, or use of any of its products shall in no event exceed the selling price of the unit.

THE EXPRESS WARRANTY SET FORTH HEREIN IS IN LIEU OF AND EXCLUDES ALL OTHER WARRANTIES, EXPRESSED OR IMPLIED, BY OPERATION OF LAW OR OTHERWISE. IN NO EVENT SHALL AEROTECH BE LIABLE FOR CONSEQUENTIAL OR SPECIAL DAMAGES.

Return Products Procedure

Claims for shipment damage (evident or concealed) must be filed with the carrier by the buyer. Aerotech must be notified within thirty (30) days of shipment of incorrect material. No product may be returned, whether in warranty or out of warranty, without first obtaining approval from Aerotech. No credit will be given nor repairs made for products returned without such approval. A "Return Materials Authorization (RMA)" number must accompany any returned product(s). The RMA number may be obtained by calling an Aerotech service center or by submitting the appropriate request available on our website (www.aerotech.com). Products must be returned, prepaid, to an Aerotech service center (no C.O.D. or Collect Freight accepted). The status of any product returned later than thirty (30) days after the issuance of a return authorization number will be subject to review.

Visit [Global Technical Support Portal](#) for the location of your nearest Aerotech Service center.

Returned Product Warranty Determination

After Aerotech's examination, warranty or out-of-warranty status will be determined. If upon Aerotech's examination a warranted defect exists, then the product(s) will be repaired at no charge and shipped, prepaid, back to the buyer. If the buyer desires an expedited method of return, the product(s) will be shipped collect. Warranty repairs do not extend the original warranty period.

Fixed Fee Repairs - Products having fixed-fee pricing will require a valid purchase order or credit card particulars before any service work can begin.

All Other Repairs - After Aerotech's evaluation, the buyer shall be notified of the repair cost. At such time the buyer must issue a valid purchase order to cover the cost of the repair and freight, or authorize the product(s) to be shipped back as is, at the buyer's expense. Failure to obtain a purchase order number or approval within thirty (30) days of notification will result in the product(s) being returned as is, at the buyer's expense.

Repair work is warranted for ninety (90) days from date of shipment. Replacement components are warranted for one year from date of shipment.

Rush Service

At times, the buyer may desire to expedite a repair. Regardless of warranty or out-of-warranty status, the buyer must issue a valid purchase order to cover the added rush service cost. Rush service is subject to Aerotech's approval.

On-site Warranty Repair

If an Aerotech product cannot be made functional by telephone assistance or by sending and having the customer install replacement parts, and cannot be returned to the Aerotech service center for repair, and if Aerotech determines the problem could be warranty-related, then the following policy applies:

Aerotech will provide an on-site Field Service Representative in a reasonable amount of time, provided that the customer issues a valid purchase order to Aerotech covering all transportation and subsistence costs. For warranty field repairs, the customer will not be charged for the cost of labor and material. If service is rendered at times other than normal work periods, then special rates apply.

If during the on-site repair it is determined the problem is not warranty related, then the terms and conditions stated in the following "On-Site Non-Warranty Repair" section apply.

On-site Non-Warranty Repair

If any Aerotech product cannot be made functional by telephone assistance or purchased replacement parts, and cannot be returned to the Aerotech service center for repair, then the following field service policy applies:

Aerotech will provide an on-site Field Service Representative in a reasonable amount of time, provided that the customer issues a valid purchase order to Aerotech covering all transportation and subsistence costs and the prevailing labor cost, including travel time, necessary to complete the repair.

Service Locations

<http://www.aerotech.com/contact-sales.aspx?mapState=showMap>

USA, CANADA, MEXICO

Aerotech, Inc.
Global Headquarters

CHINA

Aerotech China
Full-Service Subsidiary

GERMANY

Aerotech Germany
Full-Service Subsidiary

TAIWAN

Aerotech Taiwan
Full-Service Subsidiary

UNITED KINGDOM

Aerotech United Kingdom
Full-Service Subsidiary

Appendix B: Revision History

Revision	Description
2.01	<ul style="list-style-type: none">• Absolute Encoder support on the Auxiliary I/O connector has been added.• System Wiring (best practices) drawing has been added
2.00	General Update
1.02	The following sections have been updated: <ul style="list-style-type: none">• Agency Approvals• Section 2.3.1. Primary Encoder Inputs
1.01	The following sections have been updated: <ul style="list-style-type: none">• Section 2.1.2.• Section 2.10.
1.00	New Manual

This page intentionally left blank.

Index

-EB1

Analog Inputs	98
Analog Outputs	97
Digital Inputs	94
Digital Outputs	90
I/O Option Board	89
Position Synchronized Output (PSO) Interface	99

-MX1

50

-SX1

External Shunt Option	82
-----------------------	----

2

2006/42/EC	9
2014/30/EU	9
2014/35/EU	9

A

Absolute Encoder (Auxiliary I/O Connector)	69
Absolute Encoder (Feedback Connector)	49
Absolute Encoder Schematic (Auxiliary I/O Connector)	69
Absolute Encoder Schematic (Feedback Connector)	49
AC line filter	29
Agency Approvals	11
Altitude	25
Ambient Temperature	25
Analog Encoder (Feedback Connector)	50
Analog Encoder Phasing Reference Diagram	50
Analog Encoder Schematic (Feedback Connector)	51
Analog Encoder Specifications (Feedback Connector)	50
Analog Input 0 on the Aux I/O Connector	79
Analog Input 0 Schematic (Aux I/O Connector)	79
Analog Input 0 Specifications (Aux I/O Connector)	79
Analog Input Connector [-EB1] Mating Connector Part Numbers	98
Analog Input Connector Pinout [-EB1]	98
Analog Input Pins (Aux I/O Connector)	79
Analog Input Typical Connection [-EB1]	98
Analog Inputs [-EB1]	98
Analog Output 0 on the Aux I/O Connector	78
Analog Output 0 Schematic (Aux I/O Connector)	78

Analog Output 0 Specifications (Aux I/O Connector)	78
Analog Output Connector [-EB1] Mating Connector Part Numbers	97
Analog Output Connector Pinout [-EB1]	97
Analog Output Pins (Aux I/O Connector)	78
Analog Output Specifications [-EB1]	97
Analog Output Typical Connection [-EB1]	97
Analog Outputs [-EB1]	97
Aux I/O Connector	
Analog Input 0	79
Analog Output 0	78
Auxiliary Encoder Inputs	67
Digital Inputs	75
Digital Outputs	72
High-Speed User Inputs	77
Position Synchronized Output	70
PSO	70
Aux I/O Connector Mating Connector Part Numbers	66
Auxiliary Encoder Inputs (Aux I/O Connector)	67
Auxiliary I/O Connector	66
Auxiliary I/O Connector Pinout	66
Auxiliary I/O Pins (Aux I/O Connector)	67

B

BiSS absolute encoder	49,69
Brake Connected to the Feedback Connector	59
Brake Control Relay Specifications	59
Brake Output Connector Pinout	80
Brake Output Pins on the Feedback Connector	59
Brake Outputs (Feedback Connector)	59
Brake Power Supply Connector	80
Brake Power Supply Connector Mating Connector Part Numbers	80
Brushless Motor Configuration (Motor Power Output Connector)	39
Brushless Motor Connections (Motor Power Output Connector)	39
Brushless Motor Phasing Goal	41
Brushless Motor Phasing Oscilloscope Example	41
Brushless Motor Powered Motor Phasing	40
Brushless Motor Unpowered Motor and Feedback Phasing	41

C			
Cable Wires		Digital Input Specifications (Aux I/O Connector)	75
Brushless Motors	39	Digital Input Specifications [-EB1]	94
DC Brush Motors	42	Digital Inputs (Aux I/O Connector)	75
Stepper Motors	44	Digital Inputs [-EB1]	94
Cables		Digital Inputs Connected to a Current Sinking Device [-EB1]	96
HyperWire	81	Digital Inputs Connected to a Current Sourcing Device [-EB1]	96
Sync Port	84	Digital Inputs Connected to Current Sinking Devices (Aux I/O Connector)	76
Cables and Accessories	101	Digital Inputs Connected to Current Sourcing Devices (Aux I/O Connector)	76
cables, examining	106	Digital Inputs Schematic (Aux I/O Connector)	75
CAN/CSA-C22.2 No. 61010-1	11	Digital Inputs Schematic [-EB1]	95
Check for fluids or electrically conductive material exposure	106	Digital Output 1 Connector [-EB1] Mating Connector Part Numbers	91
Cleaning	106	Digital Output 1 Connector Pinout [-EB1]	91
Commands		Digital Output 2 Connector [-EB1] Mating Connector Part Numbers	91
Sync	84	Digital Output 2 Connector Pinout [-EB1]	91
connections, examining	106	Digital Output Pins (Aux I/O Connector)	72
Continuous Output Current specifications	20	Digital Output Schematic (Aux I/O Connector)	73
Control and Motor Power Wiring using a TM3 or TM5 Transformer	36	Digital Output Specifications (Aux I/O Connector)	72
Control Board Fuse Specifications	107	Digital Output Specifications [-EB1]	90
Control Supply Connections	28	Digital Outputs (Aux I/O Connector)	72
Control Supply Connector	28	Digital Outputs [-EB1]	90
Mating Connector Part Numbers	28	Digital Outputs Connected in Current Sinking Mode (Aux I/O Connector)	74
Wiring Specifications	28	Digital Outputs Connected in Current Sinking Mode [-EB1]	93
Control Supply specifications	20	Digital Outputs Connected in Current Sourcing Mode (Aux I/O Connector)	74
cooling vents, inspecting	106	Digital Outputs Connected in Current Sourcing Mode [-EB1]	93
Customer order number	27	Digital Outputs Schematic [-EB1]	92
		Dimensions	23
		Dimensions (without -EB1)	23
		Dimensions with -EB1	24
		Drawing number	27
		Drive and Software Compatibility	26
		E	
		Efficiency of Power Amplifier specifications	20
		Electrical Specifications	20
		Electromagnetic Compatibility (EMC)	9
		EMC/CE Compliance	37
		Enclosure	22

encoder		Figure	
absolute	49,69	-EB1 I/O Option Board Connectors	89
Encoder and Hall Signal Diagnostics	40	Absolute Encoder Schematic (Auxiliary I/O Connector)	69
Encoder Fault Input (Feedback Connector)	55	Absolute Encoder Schematic (Feedback Connector)	49
Encoder Fault Input Pin on the Feedback Connector	55	Analog Encoder Schematic (Feedback Connector)	51
Encoder Input (Feedback Connector)	47	Analog Input 0 Schematic (Aux I/O Connector)	79
Encoder Input Pins on the Feedback Connector	47	Analog Input Typical Connection [-EB1]	98
Encoder Phasing	52	Analog Output 0 Schematic (Aux I/O Connector)	78
Encoder Phasing Reference Diagram	52	Analog Output Typical Connection [-EB1]	97
End of Travel Limit Input (Feedback Connector)	56	Brake Connected to the Feedback Connector	59
End of Travel Limit Input Connections	57	Brushless Motor Configuration (Motor Power Output Connector)	39
End of Travel Limit Input Diagnostic Display	58	Control Supply Connections	28
End of Travel Limit Input Pins on the Feedback Connector	56	DC Brush Motor Configuration (Motor Power Output Connector)	42
End of Travel Limit Input Schematic	57	Digital Inputs Connected to a Current Sinking Device [-EB1]	96
End of Travel Limit Phasing	58	Digital Inputs Connected to a Current Sourcing Device [-EB1]	96
EnDat absolute encoder	49,69	Digital Inputs Connected to Current Sinking Devices (Aux I/O Connector)	76
Environmental Specifications	25	Digital Inputs Connected to Current Sourcing Devices (Aux I/O Connector)	76
EU 2015/863	9	Digital Inputs Schematic (Aux I/O Connector)	75
examining parts		Digital Inputs Schematic [-EB1]	95
cables	106	Digital Output Schematic (Aux I/O Connector)	73
connections	106	Digital Outputs Connected in Current Sinking Mode (Aux I/O Connector)	74
examining, dangerous fluids	106	Digital Outputs Connected in Current Sourcing Mode (Aux I/O Connector)	74
examining, dangerous material	106	Digital Outputs Schematic [-EB1]	92
External Shunt Option [-SX1]	82	Dimensions (without -EB1)	23
		Dimensions with -EB1	24
F		End of Travel Limit Input Connections	57
Feedback Connector	46	End of Travel Limit Input Diagnostic Display	58
Absolute Encoder	49,69	End of Travel Limit Input Schematic	57
Analog Encoder	50	Hall-Effect Inputs Schematic	53
Brake Outputs	59	High-Speed Inputs	77
Encoder Fault Input	55	Home Limit Input Connections	57
Encoder Input	47	Home Limit Input Diagnostic Display	58
End of Travel Limit Input	56	Home Limit Input Schematic	57
Hall-Effect Inputs	53	Isolated Output Current Sinks Schematic (PSO)	100
Home Limit Input	56	Isolated Output Current Sources Schematic (PSO)	100
Pinout	46	Motor Supply Connections	29
Primary Encoder Input	47	Outputs Connected in Current Sinking Mode [-IO]	93
RS-422 Line Driver Encoder	48,68	Outputs Connected in Current Sourcing Mode [-EB1]	93
Sine Wave Encoder	50		
Square Wave Encoder	48,68		
Thermistor Input	54		
Travel Limit Input	56		
Feedback Monitoring	40		

PSO Specifications [-EB1]	99	Square Wave Encoder Specifications (Feedback Connector)	48,68
PWM Switching Frequency specifications	20	Standard Features	18
R			
Resolute absolute encoder	49,69	Stepper Motor Configuration	44
Revision History	111	Stepper Motor Connections (Motor Power Output Connector)	44
RS-422 Encoder Specifications (Feedback Connector)	48,68	Stepper Motor Phasing	45
RS-422 Line Driver Encoder	48,68	STO	60
S			
Safe Torque Off Input (STO)	60	Connector Pinout	60
Safety Procedures and Warnings	13	Diagnostics	65
serial data stream	49,69	Electrical Specifications	61
serial number	27	External Delay Timer	63
Sine Wave Encoder (Feedback Connector)	50	Functional Description	63
Sine Wave Encoder Phasing Reference Diagram	50	Mating Connector Part Numbers	60
Sine Wave Encoder Schematic (Feedback Connector)	51	Motor Function Relative to the STO Input State	64
Sine Wave Encoder Specifications (Feedback Connector)	50	Signal Delay	64
Specifications		Standards	62
Analog Encoder (Feedback Connector)	50	Standards Data	62
Analog Input 0 (Aux I/O Connector)	79	Startup Validation Testing	64
Analog Output 0 (Aux I/O Connector)	78	Timing	65
Analog Outputs [-EB1]	97	Typical Configuration	61
Brake Control Relay	59	Sync-Related Commands	84
Control Board Fuses	107	Sync Port Cables	84
Control Supply Connector Wiring	28	Sync Ports	84
Differential Analog Inputs [-EB1]	98	System part number	27
Digital Inputs (Aux I/O Connector)	75	System Power Requirements	21
Digital Inputs [-EB1]	94	T	
Digital Outputs (Aux I/O Connector)	72	Table of Contents	3
Digital Outputs [-EB1]	90	Thermistor Input (Feedback Connector)	54
High-Speed Inputs	77	Thermistor Input Pin on the Feedback Connector	54
Motor Supply Connector Wiring	29	Thermistor Input Schematic	54
PSO (Aux I/O Connector)	70	TM3	30
PSO [-EB1]	99	TM5	30
RS-422 Encoder (Feedback Connector)	48,68	Transformer Examples	30
Sine Wave Encoder (Feedback Connector)	50	Transformer Options	30
Square Wave Encoder (Feedback Connector)	48,68	Travel Limit Input (Feedback Connector)	56
STO Electrical Specifications	61	TTL Outputs Schematic (PSO)	100
Unit Weight	22	TV0.3-28	30
Square Wave Encoder	48,68	TV0.3-28-56-ST Transformer	30
Square Wave Encoder Inputs Schematic (Aux I/O Connector)	68	TV0.3-28-56-ST Transformer (160 VDC Bus)	33
Square Wave Encoder Schematic (Feedback Connector)	48	TV0.3-28-56-ST Transformer (40 VDC Bus)	31
		TV0.3-28-56-ST Transformer (80 VDC Bus)	32
		TV0.3-28 Transformer (40 VDC Bus)	34
		TV0.3-56	30

TV0.3-56 Transformer (80 VDC Bus)	35
Two Axis Joystick Interface	102
Two Axis Joystick Interface (to the I/O board of two drives)	103
Typical STO Configuration	61

U

Unit Weight	22
Unpacking the Chassis	27
Use	25
User Power Supply specifications	20

W

Warranty and Field Service	109
Wire Colors for Aerotech-Supplied Brushless Motor Cables	39
Wire Colors for Aerotech-Supplied DC Brush Motor Cables	42
Wire Colors for Aerotech-Supplied Stepper Motor Cables	44

This page intentionally left blank.