

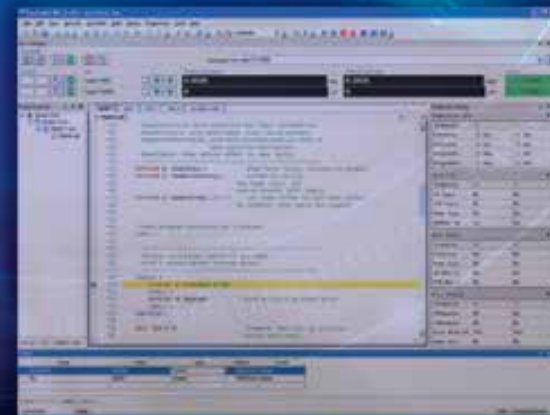

Integrated Motion and Machine Control Solutions



Aerotech's Advanced Automation Technologies: 46 years in the making... and going strong...



- Controls
- Software
- Amplifiers
- Motors
- PLC
- Fieldbus
- I/O
- Vision
- Peripherals
- Robotics
- Data Acquisition

WORLD HEADQUARTERS

Aerotech, Inc.
101 Zeta Drive, Pittsburgh, PA 15238
Ph: 412-963-7470
Email: sales@aerotech.com

Aerotech United Kingdom
The Old Brick Kiln, Ramsdell, Tadley
Hampshire RG26 5PR, UK
Ph: +44 (0)1256 855055
Email: sales@aerotech.co.uk

Aerotech Germany
Gustav-Weißkopf-Str. 18, 90768 Fürth, Germany
Ph: +49 (0)911 967 9370
Email: sales@aerotechgmbh.de

Aerotech Japan
WBG Marive East 22F, 2-6-1 Nakase
Mihama Ward, Chiba, Japan 261-7122
Ph: +81 (0)50 5830 6821
Email: sales@aerotechkk.co.jp

Aerotech China
Room 101, No. 28 Building, Tianlin Road 140
Xuhui District, Shanghai, China 200234
Ph: +86 (21) 6126 1058
Email: sales@aerotech.com

Aerotech Taiwan
5F, No 32, Aly 18, Lane 478, Ruiguang Rd
Neihu District, Taipei City, 114, Taiwan R.O.C.
Ph: +886 (0)2 8751 6690
Email: sales@aerotech.tw

Aerotech France
28300 Coltainville, France
Ph: +33 2 37 21 87 65
Email: cmonnier@aerotech.com

Aerotech Italy
20089 Rozzano (MI), Italy
Ph: +39 02 94759294

Copyright © 2017, Aerotech, Inc.
Information in this brochure is subject to change without notice.

Introduction

- 4 Aerotech Integrated Motion and Machine Control

Motion Composer Software

- 7 Setup and Configuration
- 9 Advanced Diagnostic and Tuning Capabilities
- 15 Integrated Development Environment and .NET
- 18 Integrated Automation: MotionPAC – PLC and Motion
- 32 Operator Interface
- 33 Software Architecture

Controller Architecture

- 34 Automation 3200 Digital Automation Platform
- 36 Ensemble Stand-Alone Multi-Axis Controller
- 38 Soloist Stand-Alone Single-Axis Controller
- 40 Controller and Drive Technology

Controller Features

- 48 Standard Control Capabilities
- 52 Advanced Control Capabilities
- 65 Fieldbus and Networking
- 66 Hexapod and Piezo Controls

Quick Reference

- 68 Controller Comparison Chart
- 72 Hardware Comparison Chart
- 74 Servomotors

Corporate Overview

- 81 Markets and Industries
- 88 Worldwide Training and Support
- 89 ISO Certification
- 90 Aerotech at a Glance

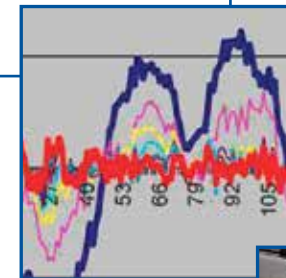
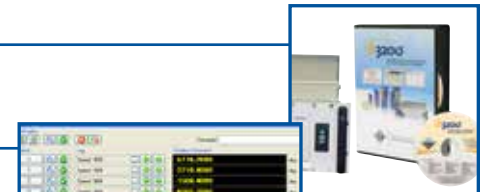

Configure Your Automation Solution with Aerotech

Common Software Platform: Tools, Powerful Programming Environment, Calculators, Diagnostics

Aerotech Integrated Motion and Machine Control

- High performance
- Easy to use
- Flexible
- Scalable
- Networked
- Lowest cost of ownership
- Advanced control technology
- Controls servo, piezo, voice coil, and stepper motor

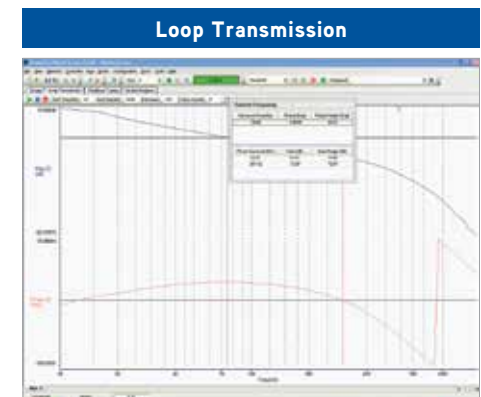
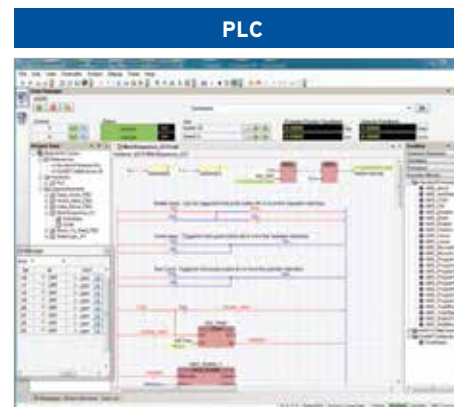
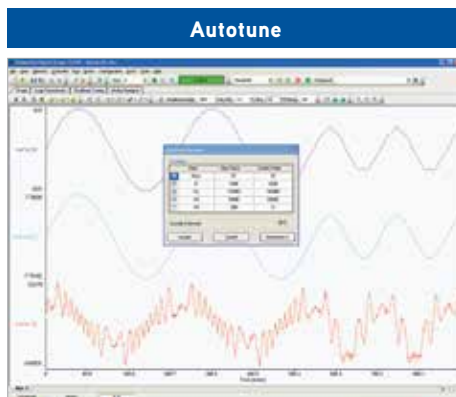
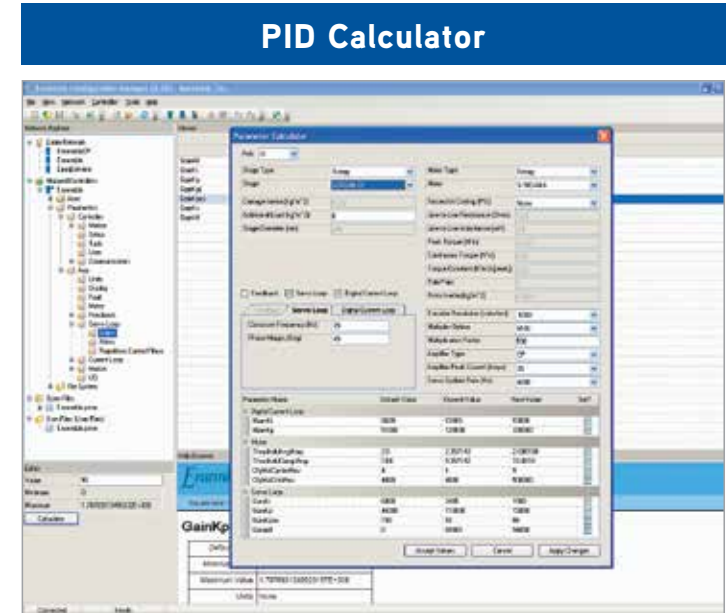
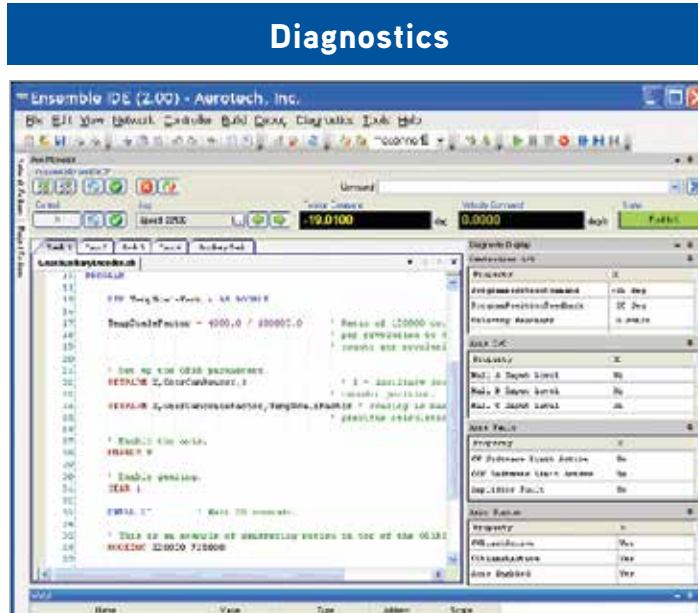

Develop your own applications with .NET, C#, VB.NET, C, LabVIEW®, Tango, AeroBasic™ or PLC languages

Award-Winning Controllers



Automation 3200

- PC-based
- 1 to 32 axes of coordinated motion
- Up to 32 tasks
- RS-274 (G-code)
- Advanced features for demanding applications
- PWM or linear drives (up to 150 A)
- Scanner control for marking
- Tightly integrated laser functionality
- Retro-fit package for old controls
- Integrated PLC and Motion - MotionPAC



Ensemble™

- Stand-alone
- 1 to 10 axis controller
- Up to 4 tasks
- Versatile, cost-effective, coordinated motion
- PWM or linear drives (10-150 A peak)
- Drives brushless, linear, rotary, DC brush or stepper motors
- Desktop, rack mount or panel mount



Soloist™

- Stand-alone
- Network up to 1024 single axes
- Up to 4 tasks
- Elegant, economical, versatile controller
- PWM or linear drives (10-150 A peak)
- Drives brushless, linear, rotary, DC brush or stepper motors



Piezo Controls

- Network up to 32
- Coordinated motion with servo and stepper motor stages
- Available in desktop or rackmount configuration
- Powered by Automation 3200 motion controller

Configure Your Automation Solution with Aerotech

Linear and Rotary Servomotors/Accessories



Fieldbus and Network Connectivity

- EtherNet/IP™
- PROFINET
- Modbus®/TCP
- RS-232
- EtherCAT™
- Ethernet TCP/IP
- USB
- GPIB

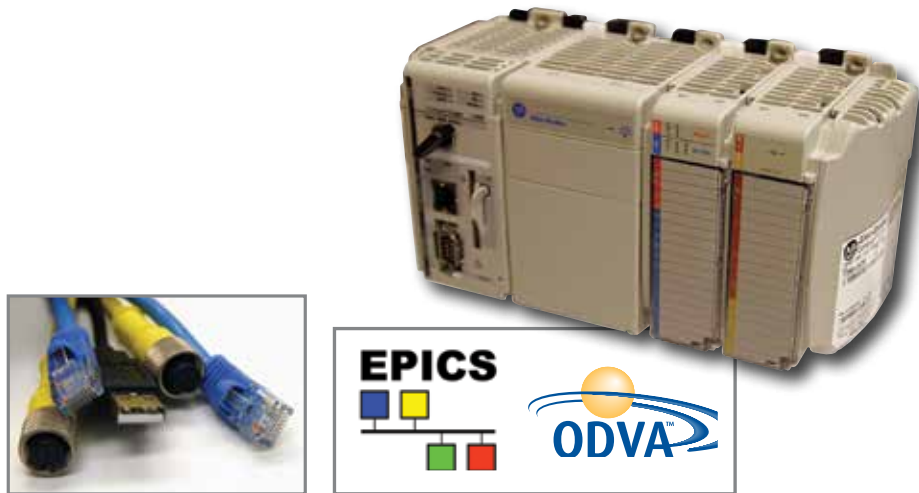

Custom Controls, Drives and Motors

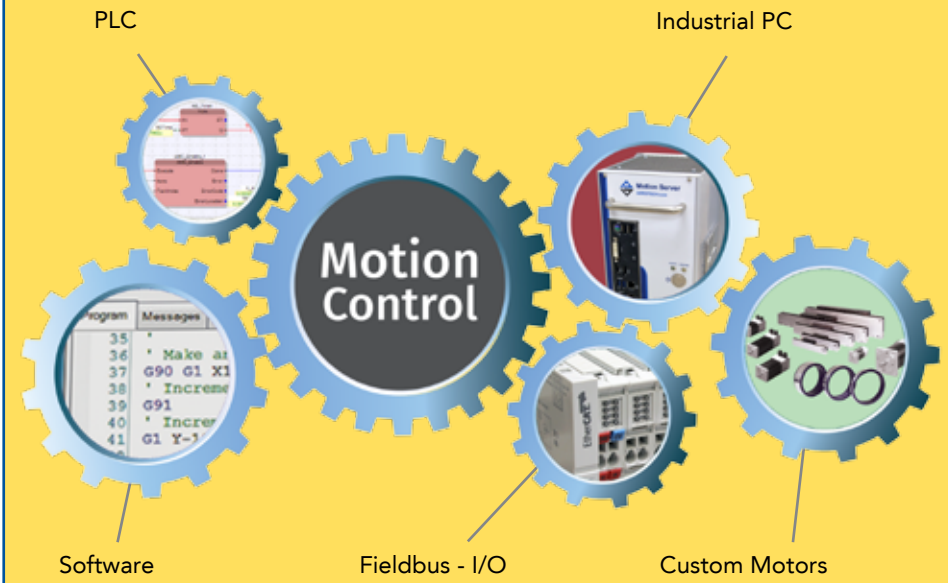

Scalable Automation Control Software for Simple Applications and the Power User

Integrated Configuration Manager for Easy Setup

Compare parameter files

Standard Windows® menus

See all the controllers on the network

Work with this controller

Network Explorer for project management

File space on the controller

Extensive calculators for system setup

Tool tips

Standard motion toolbars

Configurable workspace with your preferences

Hyperlink to associated subjects

Context sensitive integrated help

Name	X	Y	Z	U
DgMotType	3	3	3	0
DgMotCyclePer	4	4	4	4
DgMotCovRes	4000	4000	4000	1000
DgMotDistMag	0	0	0	0
DgMotSelSteps	1	1	1	1
DgMotSelInetSec	3000	10	10	10
DgMotStpperRes	4000	4000	4000	4000
DgMotStpperHighCur	2	2	2	2
DgMotStpperLowCur	1	1	1	1
DgMotStpperOGan	0	0	0	0
DgMotStpperVelVel	0	0	0	0

Mode	Motor Type
0	AC brushless with Hall effect switches
1	AC brushless without Hall effect switches ⁽¹⁾
2	DC brush

Motion Composer: Use the same Aerotech software with the A3200, Ensemble, or Soloist

- Configuration Manager to organize your applications
- Calculators for quick and easy setup
- Extensive diagnostics for commissioning
- Integrated Development Environment for fast development
- Data Acquisition and Analysis Tools for increasing performance
- Fully compliant .NET 2.0 shortens the development cycle

Scalable Automation Control Software for Simple Applications and the Power User

Calculators for Quick and Easy Setup

The screenshot shows the 'Parameter Calculator' window in a software application. The window is divided into several sections: a top section for selecting the axis and motor type, a middle section for selecting feedback and amplifier types, and a bottom section for a table of parameters. Annotations with red arrows point to various parts of the interface:

- Easily switch axis to be configured:** Points to the 'Axis' dropdown menu at the top left.
- Current loop calculator:** Points to the 'Feedback' section, specifically the 'Digital Current Loop' checkbox.
- PID gain calculator:** Points to the 'Feedback' section, specifically the 'Feedback' checkbox.
- Configure feedback for user units:** Points to the 'Units' dropdown menu in the 'Feedback' section.
- Select your motor or add a custom motor:** Points to the 'Motor Type' dropdown menu.
- System knows all parameters of Aerotech components:** Points to the 'Motor' dropdown menu.
- Select amplifier type:** Points to the 'Amplifier Type' dropdown menu.
- Directly enter any parameter values here:** Points to the 'New Value' column in the parameter table.
- Summary of default, current and new values for all parameters:** Points to the entire parameter table.

The parameter table contains the following data:

Parameter Name	Old Value	Current Value	New Value	Set?
Digital Current Loop				
IGainK	8600	8600	27000	<input type="checkbox"/>
IGainKp	51000	51000	62000	<input type="checkbox"/>
Motor				
ThresholdVrgAmp	2.6	2.6	2.367143	<input type="checkbox"/>
ThresholdClampAmp	10.6	10.6	9.367142	<input type="checkbox"/>
Servo Loop				
GainK	6000	600	3000	<input type="checkbox"/>
GainKp	44000	67000	140000	<input type="checkbox"/>

Extensive Diagnostics for all System Signals and Variables Shorten Debug and Startup Time

Control all axes at once

Multiple tabs for organized programming

System toolbar for system control

Axis toolbar for control of each axis

Standard toolbar for program control

Issue immediate commands without operator interface open

Dockable windows for custom work environment

Configurable to see only the information you want

Real-time readout of system state variables

Real-time access to system signals

Real-time reporting of all faults

Real-time system information

View task status as needed

Watch any variables as the program runs

Pop-up error reporting

Compiler output screen

The screenshot shows the Ensemble software interface. At the top, there are three toolbars: a system control toolbar, an axis control toolbar, and a standard program control toolbar. Below these is a control panel for axes X, Y, Z, and U, each with speed and position command fields. A central window displays the 'Ensemble' logo. To the right, several diagnostic windows are docked, showing real-time data for 'Axis I/O', 'Axis I/O', 'Axis Fault', and 'Axis Status'. At the bottom, there is a task list window and a compiler output window. Red arrows point from text labels to these various interface elements.

Scalable Automation Control Software for Simple Applications and the Power User

Advanced Diagnostic and Tuning Capabilities Minimize Startup Time and Allow Easy Optimization of Motion

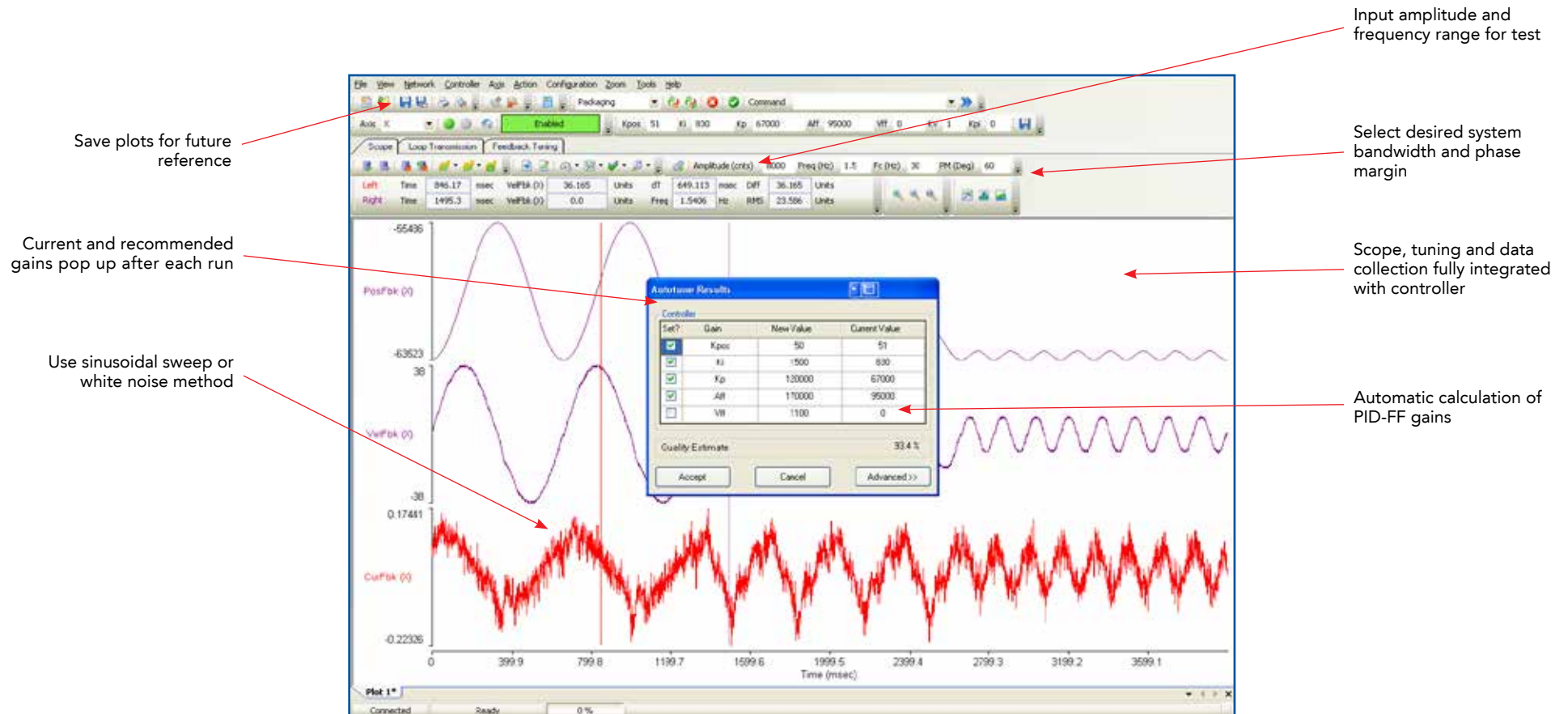

Use Encoder Tuning Tool to Increase System Accuracy

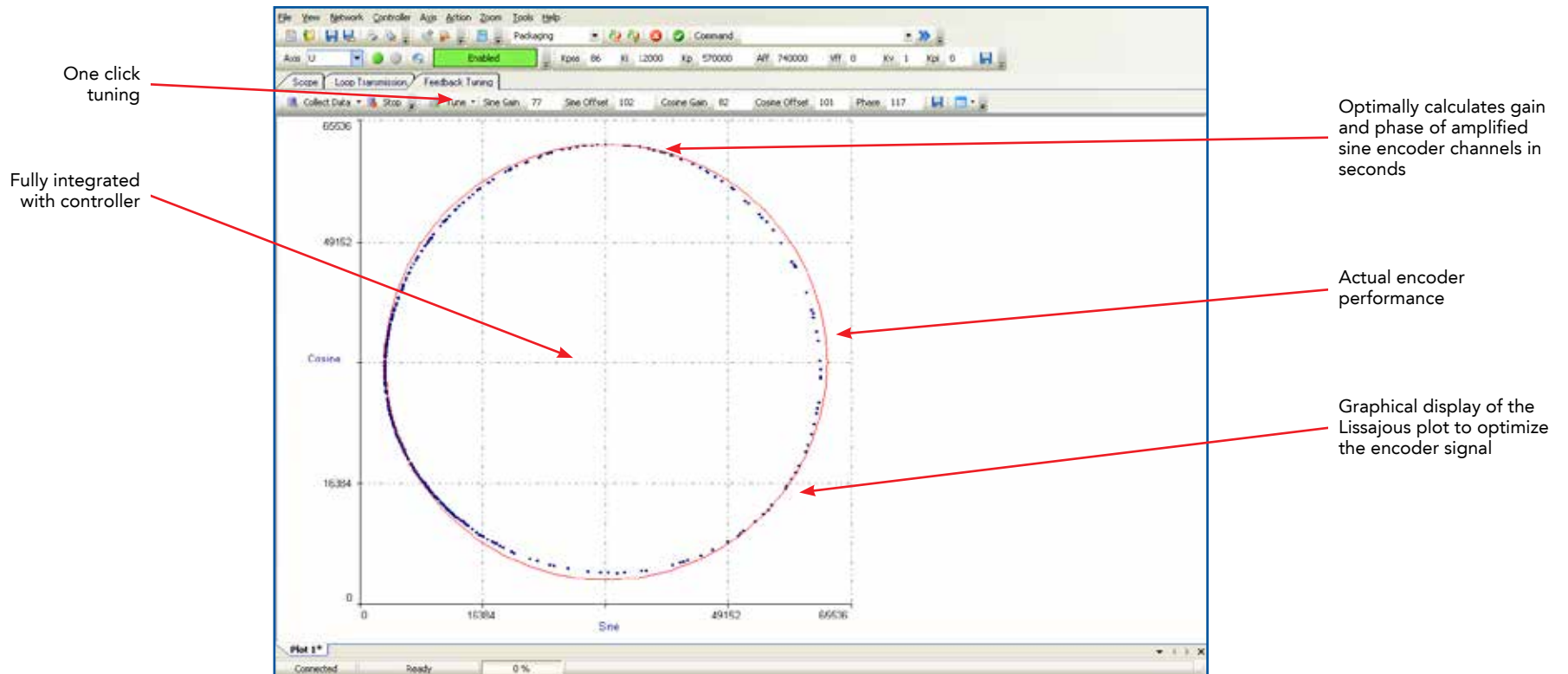

Scalable Automation Control Software for Simple Applications and the Power User

Loop Transmission is a Tuning and Diagnostic Utility that Greatly Enhances System Performance

Graphical loop shaping — add filters or change gain by dragging the gain curve, and the filter coefficients and PID gains are calculated automatically

Automatic calculation of gain margin

Identify resonances and use filters

Calculator and loop shaping to increase performance

Automatic calculation of phase margin

System frequency response or Bode plot

Open or closed loop response

Analyze position loop, velocity loop or current loop

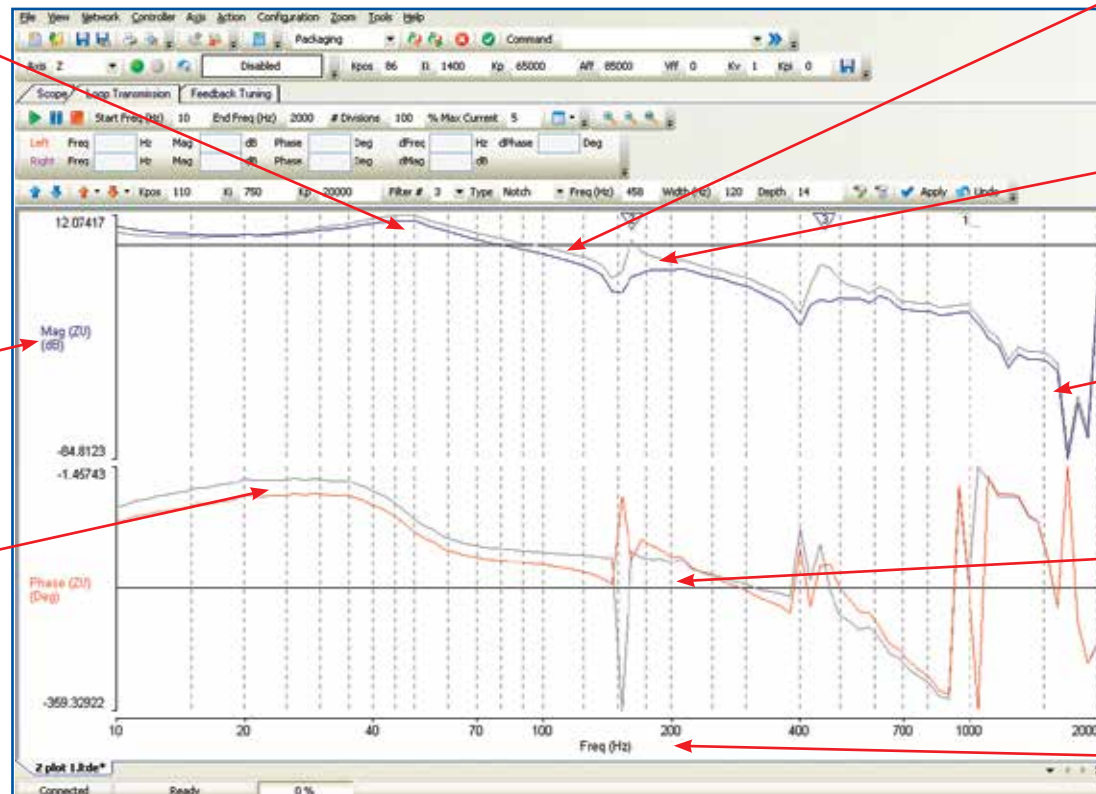

Fully Integrated Digital Filter Calculator Makes Performance Enhancements Easy

Select your filter type: low pass, high pass, notch, resonant, lead/lag

Axis selection

Add up to eight filters per axis

Configure filters for your application by specifying frequency, depth and width

Discrete time gains are automatically calculated and stored in the parameter file

Cursor control to read out gain and phase

Composite frequency response of all filters

Store all parameters in the parameter file

The screenshot shows the 'Digital Filter Calculator' window. At the top, there's a title bar and a close button. Below it, an 'Axis' dropdown menu is set to 'X'. The main area is divided into four columns for Filter 1, 2, 3, and 4. Each column has a 'Filter Type' dropdown, a 'Parameters' section with input fields, and a 'Coefficients' table. Filter 1 is 'LowPass' with a cutoff frequency of 1000 Hz. Filter 2 is 'Notch' with a center frequency of 1000 Hz, width of 50 Hz, and depth of 40 dB. Filter 3 is 'Resonant' with a center frequency of 100 Hz, width of 50 Hz, and gain of 20 dB. Filter 4 is 'None'. Below the filter settings, there are readouts for 'Left' and 'Right' channels showing frequency, magnitude, and phase. At the bottom, there's a graph showing 'Magnitude (dB)' and 'Phase (deg)' vs 'Frequency (Hz)'. The graph has two y-axes and a single x-axis. A cursor is positioned on the graph to read values. At the very bottom, there are 'Remove', 'Accept', 'Cancel', and 'Apply' buttons.

N0	0.226153999567032
N1	0.452306985855103
N2	0.226153999567032
D1	-0.280945986509323
D2	0.185561001300812

N0	0.980937453794024
N1	-2.17769114479404E-16
N2	0.98052351650469
D1	-2.17769114479404E-16
D2	0.961489805644493

N0	1.03435124810207
N1	-1.96783705291467
N2	0.958015141262473
D1	-1.96783705291467
D2	0.992366389309541

N0	1
N1	0
N2	0
D1	0
D2	0

Left Freq 146.17 Hz Mag 1.41 dB Phase -40.67 Deg dFreq -933.51 Hz dPhase -70.26 Deg
Right Freq 1079.7 Hz Mag -7.38 dB Phase -110.93 Deg dMag 8.79 dB

19.99941
Magnitude (dB)
-100
47.20826
Phase (deg)
-189.42051

0 199.99 399.98 599.97 799.96 999.95 1199.94 1399.93 1599.92 1799.91
Frequency (Hz)

Remove Accept Cancel Apply

Scalable Automation Control Software for Simple Applications and the Power User

Integrated I/O Panel for Debug, Commissioning or Operations

The screenshot displays the software's I/O panel, which is divided into several functional areas:

- Control Panel:** Features jog buttons for X, Y, Z, and U axes, each with a speed of 3600. It also shows position and velocity commands for each axis, with status indicators (Disabled, Enabled).
- Network Explorer:** A tree view on the left showing the project structure, including network, controller, and computer components.
- Digital I/O:** A central table for monitoring and setting digital I/O across three ports (Pot 0, Pot 1, Pot 2). Each port has 8 channels (IN/OUT) with status indicators (OFF/ON) and dropdown menus for setting values.
- Analog I/O:** A section at the bottom for monitoring and setting analog I/O across two channels (Channel 0 and Channel 1). It shows IN and OUT voltage levels and setpoint values.
- Diagnostic Display:** A panel on the right showing various system parameters and fault status, such as Position Command, Position Feedback, Program Position, and various fault indicators like Position Error Fault and Over Current Fault.

Annotations with red arrows point to specific features:

- "View I/O axis information and program at the same time" points to the top control panel.
- "Monitor digital I/O control" points to the Digital I/O table.
- "Monitor analog I/O" points to the Analog I/O section.
- "Set digital I/O during test and commissioning" points to the dropdown menus in the Digital I/O table.
- "Use the I/O panel during programming to test as you go" points to the overall I/O panel area.
- "Tool tip provides physical connector and pin on the drive to easily associate electrical wiring with software variables" points to a tooltip for '1B262 Pin 3'.
- "Set analog I/O during commissioning for easy testing" points to the Analog I/O setpoint fields.

Integrated Development Environment Shortens Development Time

Hide the axis manager while programming to see more code

Visual Studio®-like project management for advanced programming

Powerful IntelliSense® capability

Insert breakpoints to debug program

Low learning curve with strict implementation of .NET naming conventions

Detailed error explanation in error list

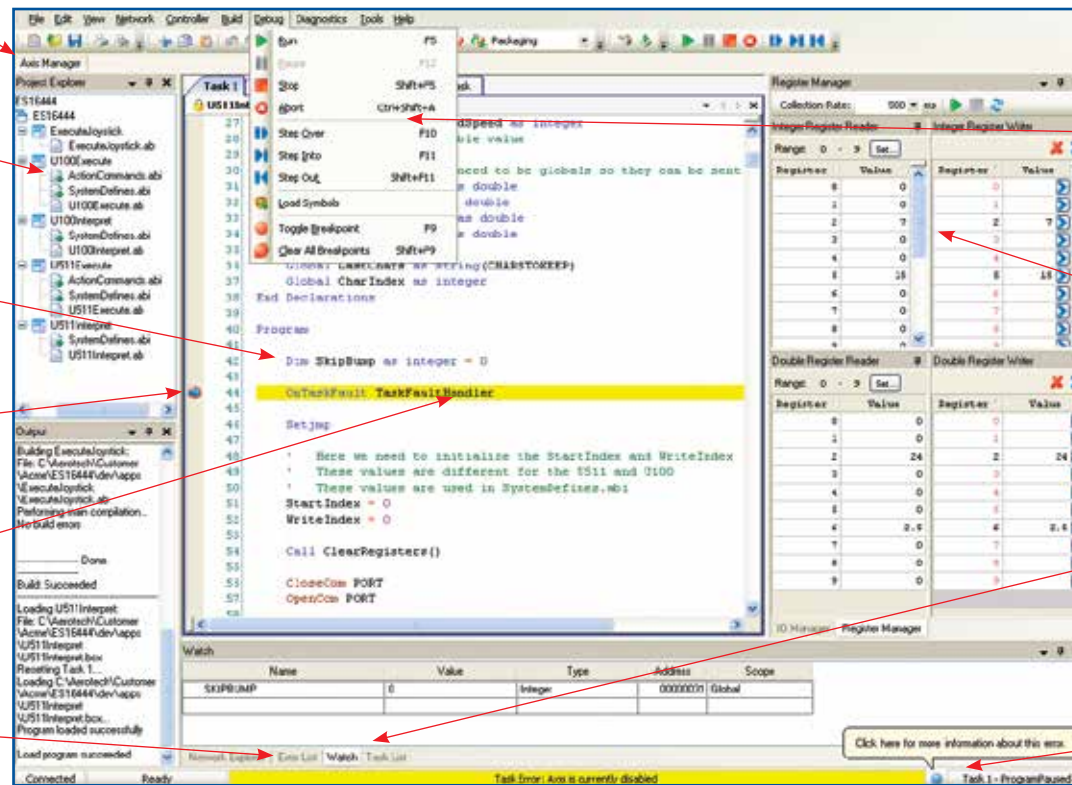

Minimize development time with debug features, break point, step in and step over

Full diagnostic instrumentation while debugging

Watch window shows variable values for easy debugging

Link to help file for description of error

Scalable Automation Control Software for Simple Applications and the Power User

Create Reusable Modules with AeroBasic™

Create reusable code with libraries and #include files

Write easy-to-read and maintainable code by using #define (rather than numeric constants)

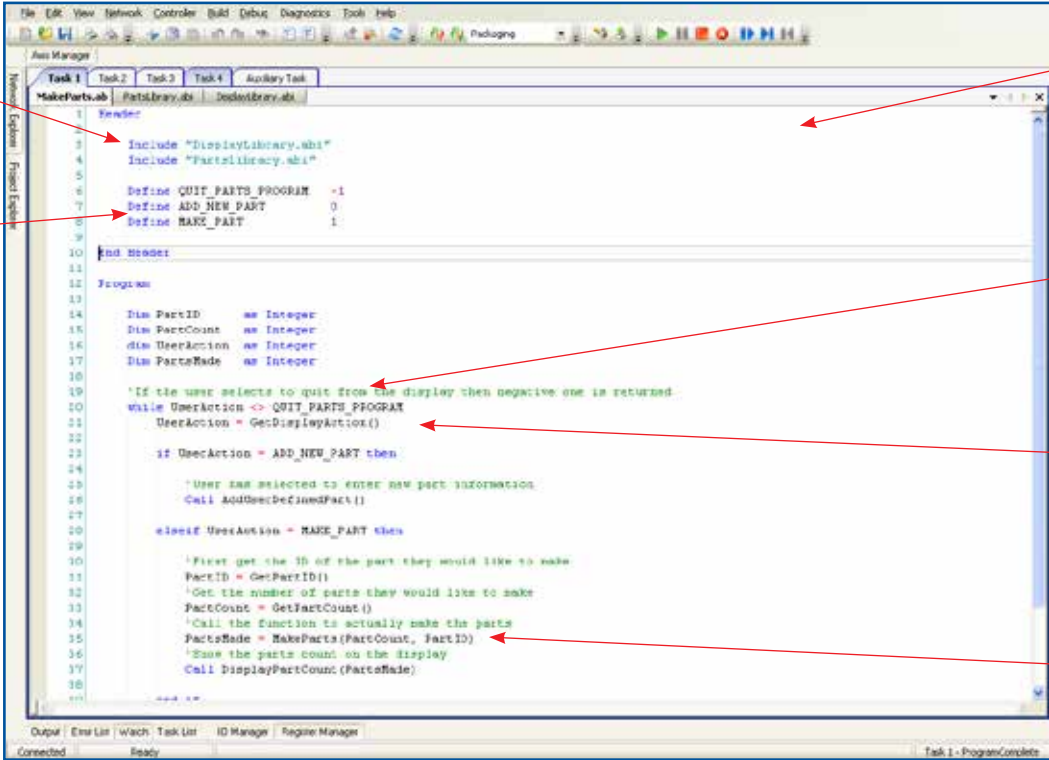

Real-time code environment

Advanced programming techniques result in code that is easy to read, simple to maintain and reusable for other projects

Protect intellectual property by using a library; permit or deny end users access to source code

Built-in software security key for OEMs

Create Easy to Maintain Code with AeroBasic™

User defined variable types allow an object-oriented approach to system design

Use structures to define your own data types

Advanced variable types such as arrays and strings allow for more advanced program design

```
1 Declarations
2 Structures to define a rectangular part with round corners
3 Type Part
4   ID as Integer
5   CornerRadius as Double
6   Width as Double
7   Length as Double
8 End Type
9 Global PartList(100) as Part
10 End Declarations
11
12 Function CutPart(Byref PartToCut as Part)
13   Home X Y
14   If PartToCut.CornerRadius = 0 then
15     Linear X PartToCut.Length F 100
16     Linear Y PartToCut.Width F 100
17     Linear X (-1)*PartToCut.Length F 100
18     Linear Y (-1)*PartToCut.Width F 100
19   else
20     Velocity On
21     Linear X PartToCut.Length F 100
22     CW X PartToCut.CornerRadius Y PartToCut.CornerRadius R PartToCut.CornerRadius
23     Linear Y PartToCut.Width F 100
24     CW X PartToCut.CornerRadius Y (-1)*PartToCut.CornerRadius R PartToCut.CornerRadius
25     Linear X (-1)*PartToCut.Length F 100
26     CW X (-1)*PartToCut.CornerRadius Y (-1)*PartToCut.CornerRadius R PartToCut.CornerRadius
27     Linear Y (-1)*PartToCut.Width F 100
28     Velocity Off
29     CW X (-1)*PartToCut.CornerRadius Y PartToCut.CornerRadius R PartToCut.CornerRadius
30   end if
31 End Function
32
33 Function MakeParts(Byval TotalParts as Integer, Byval PartID as Integer) as Integer
34   Dim PartIndexToMake as Integer = 0
35   Dim PartCount as Integer = 0
36
37   While PartID <> PartList(PartIndexToMake)
38     PartToCut = MakeParts(PartID, PartIndexToMake)
39     PartCount = PartCount + 1
40   End While
41   Return PartCount
42 End Function
```

Memory management is done by the operating system

Keeping all motion code in one function creates modularity, which brings products to market faster and reduces maintenance cost

Variable initialization reduces code size and increases readability for multiple developers

Standard program flow: while/wend for/next repeat if/then/else

Integrated Automation: MotionPAC

Program in IEC 61131-3: LD, FBD, ST

- 30% to 50% reduction in development time
- High-performance motion fully integrated with standard PLC environment
- Easy-to-use diagnostics and tools
- Standards & Flexibility: IEC 61131-3, .NET, PLCopen, PC-based

The screenshot displays the MotionPAC software interface with several key components and annotations:

- Axis Manager:** Located at the top, it shows control and status for axes Y and X, including jog speed settings and feedback values.
- Project View:** A tree view on the left showing the project structure, including hardware definitions and libraries.
- LD, FBD or ST programs:** The main workspace shows a ladder logic program (LD) with motion control blocks like 'Enable Axes', 'Home Axis', and 'Run Cycle'.
- UO Manager:** A diagnostic window at the bottom left showing I/O status for Axis Y.
- Tag database:** A 'Tag database' window on the right lists various motion control variables and functions.

Annotations with red arrows point to specific features:

- Online mode displays all Tag values:** Points to the status area of the Axis Manager.
- Axis manager:** Points to the Axis Manager window.
- Standard LD:** Points to the main ladder logic program.
- Define hardware:** Points to the hardware definition section in the Project View.
- Create libraries:** Points to the library section in the Project View.
- LD, FBD or ST programs:** Points to the main ladder logic program.
- Combine LD and FBD in the same program:** Points to the motion control blocks within the ladder logic.
- Completely integrated motion blocks:** Points to the motion control blocks within the ladder logic.
- Tag database:** Points to the Tag database window.

Integrated Automation: MotionPAC – PLC and Motion



HMI

- Program selection and run
- Jog panel
- Machine control
- Customizable buttons
- Axis manager



MotionPAC

- IEC 61131-3
- PLCopen
- Aerotech motion blocks
- Axis manager
- Extensive development & debug environment
- Simulate program

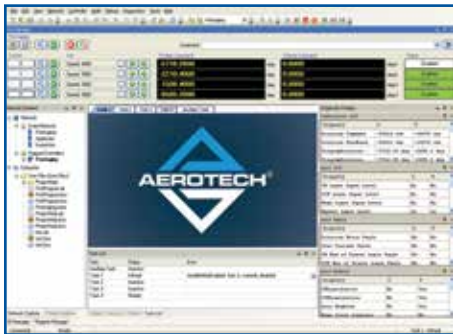

Motion Composer

- Axis manager
- Low-level motion diagnostics
- Motion programming
- Advanced control algorithms

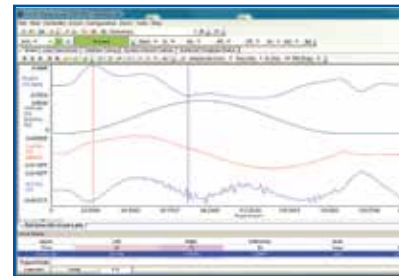

Scope

- Signal capture & analysis
- Autotuning
- Loop transmission
- Encoder tuning
- Advanced controls



Beckhoff Wago

- Data acquisition synchronized with motion & PLC
- High-speed registration
- Position Synchronized Output
- Machine interlocks
- Fieldbus I/O

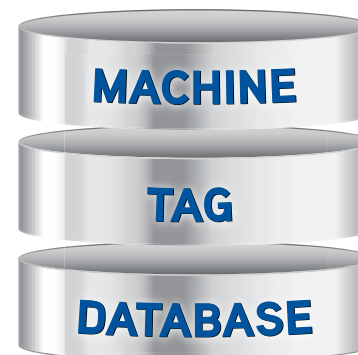

Central Machine Tag Database

- Tags available in all applications by name
- Define both local or global machine Tags
- Define Tags in I/O definition, ST, LD, FBD or motion program

Use Tags in Operator Interface by Name

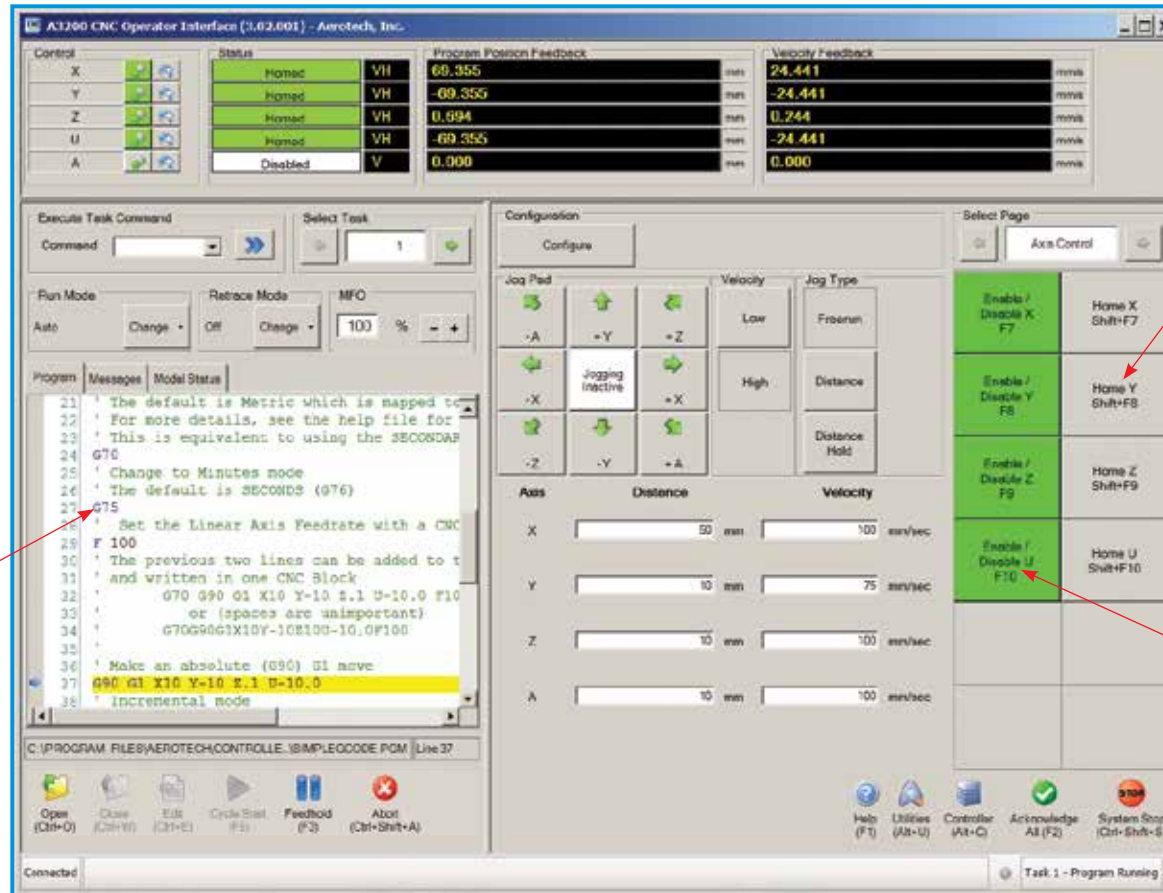

View CNC code running at same time as PLC code

Use shared Tags defined in MotionPAC by name in a button action

Use shared Tags by name in program called by a button click

Ladder Diagram

- VALUE
- TRUE
- FALSE
- COMMENT
- CONNECTOR
- JUMP
- LABEL
- RETURN
- CONTACT (NO, NC)
- COIL
- LEFT POWERRAIL
- RIGHT POWERRAIL

Function Blocks

- CTD
- CTU
- CTUD
- F_TRIG
- R_TRIG
- RS
- SR
- TOF
- TOF_R
- TON
- TON_R
- TP
- TP_R

Motion Blocks (Partial List)

- MoveAbsolute
- MoveRelative
- MoveSuperimposed
- MoveVelocity
- Home
- Stop
- PositionProfile
- MoveContinuous
- Halt
- CamIn/CamOut
- CamTableSelect
- GearInPos
- GearIn/GearOut
- Phasing

Administrative Motion Blocks (Partial List)

- ReadStatus
- ReadAxisError
- ReadParameter
- WriteParameter
- ReadActualPosition
- AbortTrigger
- ReadDigitalInput
- ReadDigitalOutput
- WriteDigitalOutput
- SetPosition

Functions (Partial List)

- ABS
- ACOS
- B_BCD_TO_DINT
- B_BCD_TO_INT
- DELETE
- DINT_TO_BOOL
- EXP
- EXPT
- FIND
- GE
- GE_STRING
- INT_TO_BOOL
- INT_TO_BYTE
- INT_TO_DINT
- INT_TO_DWORD
- LE
- LE_STRING
- LEFT
- LEN
- MULTIME
- NE
- OR
- REAL_TO_BOOL
- SEL_TO_BOOL
- SEL_TO_BYTE
- TRUNC_SINT
- UDINT_TO_BOOL

One I/O and Data Dictionary for the Machine

Integrated Development Environment Shortens Development Time

The screenshot displays the 'I/O Configuration' window. On the left, a tree view under 'PLC' shows 'IO Configure', 'Hardware', 'Configuration', 'eCLR', 'GlobalVariables', and 'LDSample1'. On the right, the 'Drive I/O' tab shows 'NDrive HPe' and 'NServo'. A table in the center maps PLC signals to Drive I/O signals. Below the table are two panels: 'Name' and 'I/O', each with columns for Name, Type, and I/O status. A status bar at the bottom indicates '16 bit(s) in 1 signal(s) selected'.

Annotations:

- Drive I/O connected to system
- Fieldbus I/O connected to the system
- I/O defined in one place
- I/O available in all applications: scope, configurator, MotionPAC (PLC) and Motion Composer
- Easily map I/O to program Tags
- Memory management automatically done by the MotionPAC

From	Signal	I/O	I/O	To	Signal	Type
PLC	eCLR.LDSample1.mfo	←	←	Drive I/O	HWIO\NServo\Signal5	WO...
PLC	eCLR.digOut	→	→	Drive I/O	HWIO\NServo\Signal3	BOOL

Name	Type	I/O
mfo	WORD	←

I/O	Name	Type
→	Signal3	BOOL
←	Signal4	INT
←	Signal5	WORD

Use Scope to Plot Any Motion, PLC, I/O, Variable or Tag

Motion variables

PLC Tags

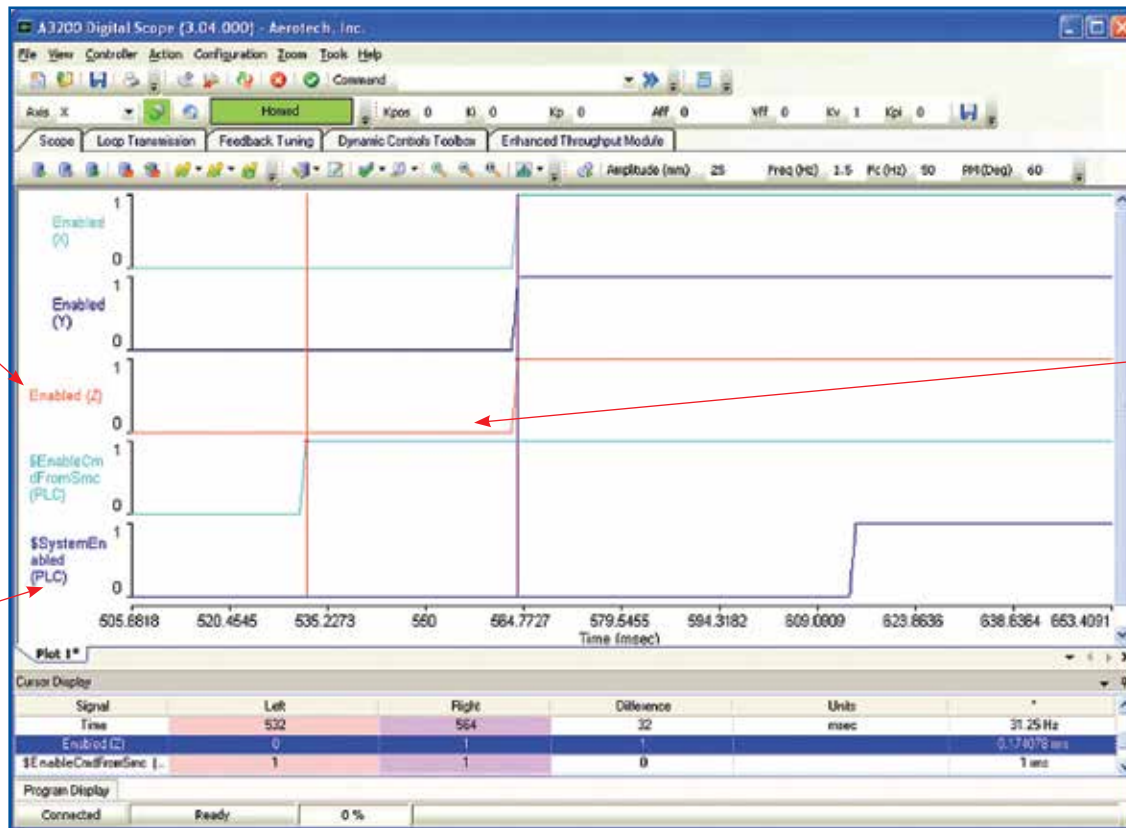

All information in Global Tag database available for real time plotting and analysis with all motion variables

SDK: Software Development Kit

Use the Aerotech standard GUI...
...or build a custom interface for your application

- Easy to use
- Faster development
- Lower maintenance cost

- C#
- VB.NET®
- Managed C++
- LabVIEW® (VIs provided)
- C Library
- EPICS

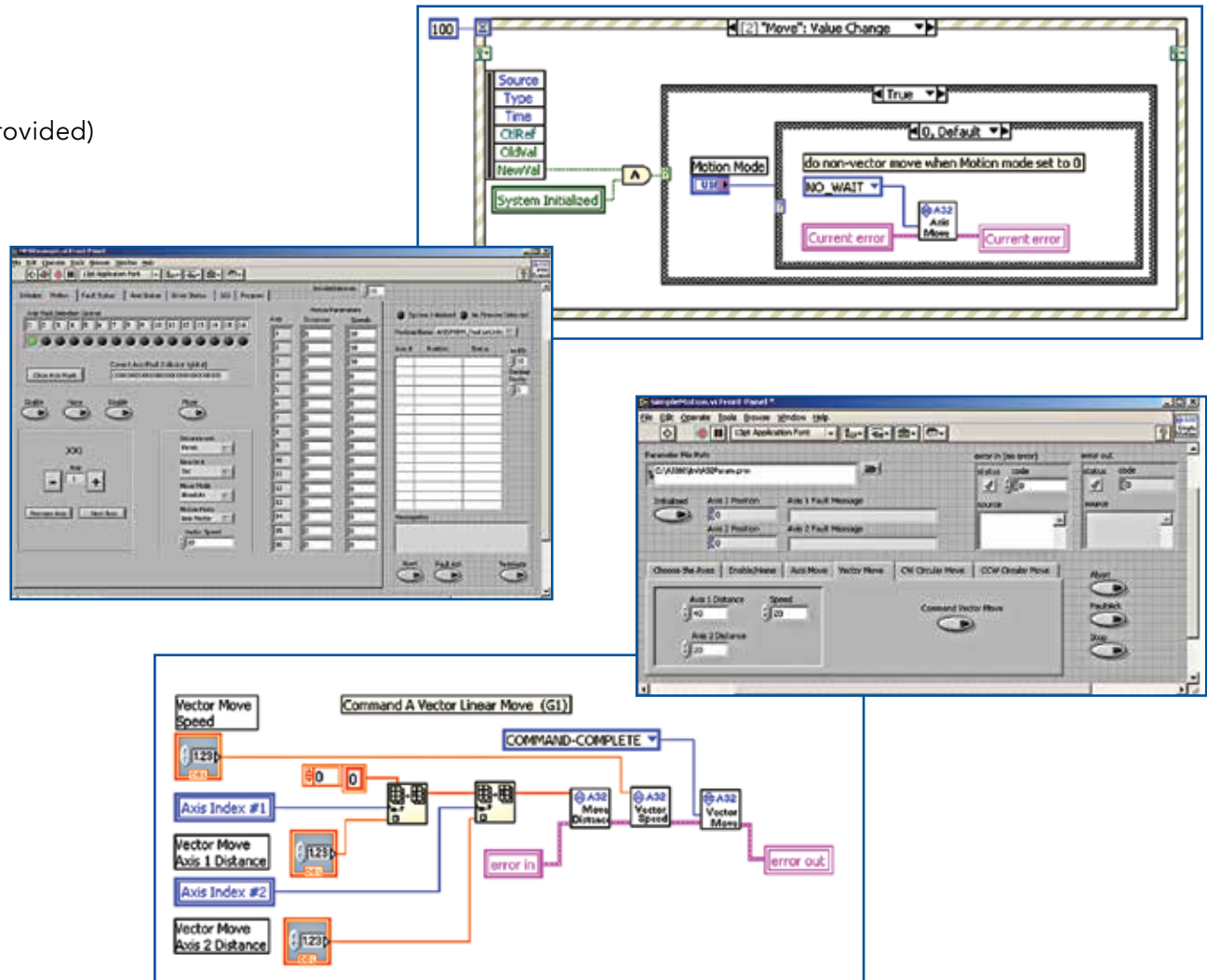

.NET Library

- High-end motion with a custom GUI
- Use the best language for the application
- Fully functional libraries for each language

All Aerotech applications are written using the .NET library. Aerotech provides customers with the same tools used at Aerotech.

TAKE ADVANTAGE OF:

.NET Framework 2.0

- Generics
- Enumerations
- Indexers
- Events
- Exceptions

Object Model

- Well-organized structure with two main classes: network and controllers
- Common features are higher in the hierarchy
- Minimal code required to accomplish the task at hand

Libraries Include:

- Initialization functions
- Global data functions
- Motion functions
- Error handling
- Status and position functions
- Analog and digital I/O functions
- Parameter functions
- Run CNC program functions
- Utility functions
- Get and set variable functions

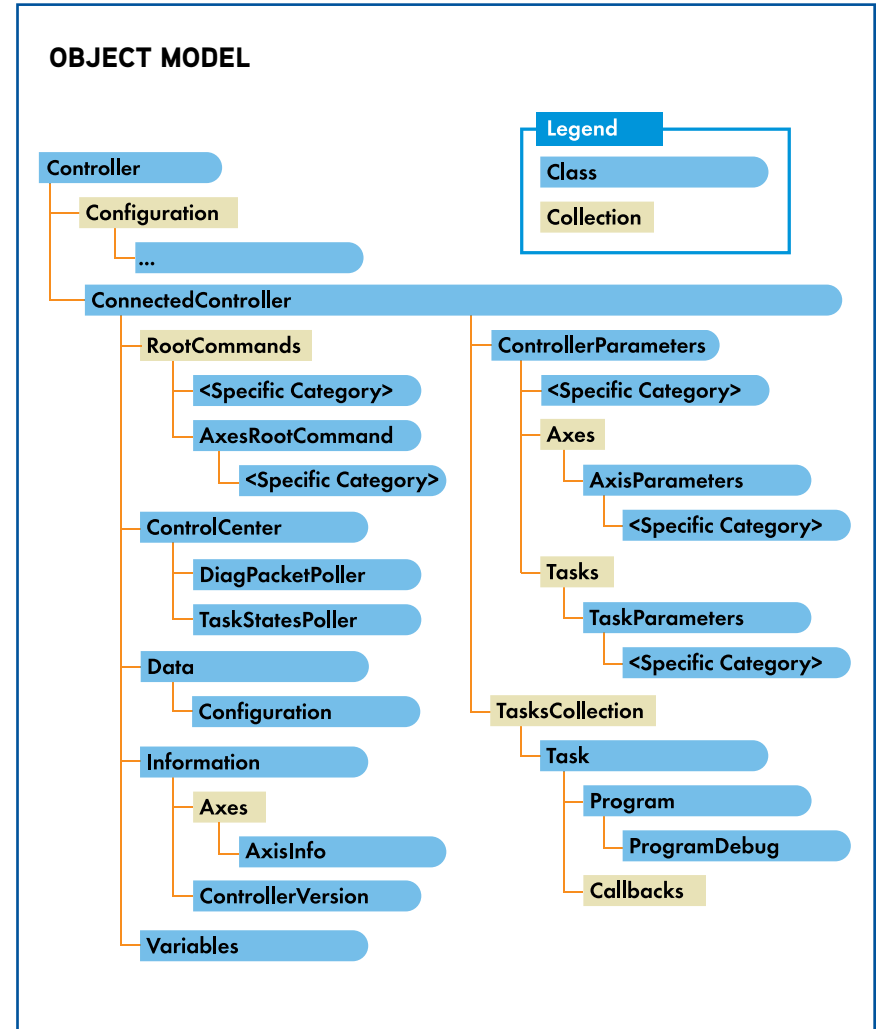

Motion Designer: Graphical Trajectory Generation and Data Analysis

- Minimize programming time
- Import actual data
- Import from Excel or MATLAB®

Applications

- Dynamic environment simulation
- Sensor or component testing
- Gyros or accelerometers; tracking or beam-steering gimbals
- Crash sensors and roll-over sensors

Create and modify multi-axis trajectories using predefined building blocks to provide rapid motion prototyping

Perform data analysis such as FFT, max, min, average, rms and standard deviation from an existing trajectory for diagnosing system performance

Add standard filter types: notch, resonant, low pass and high pass

Enter standard filter frequency parameters

Digital filter coefficients are automatically calculated

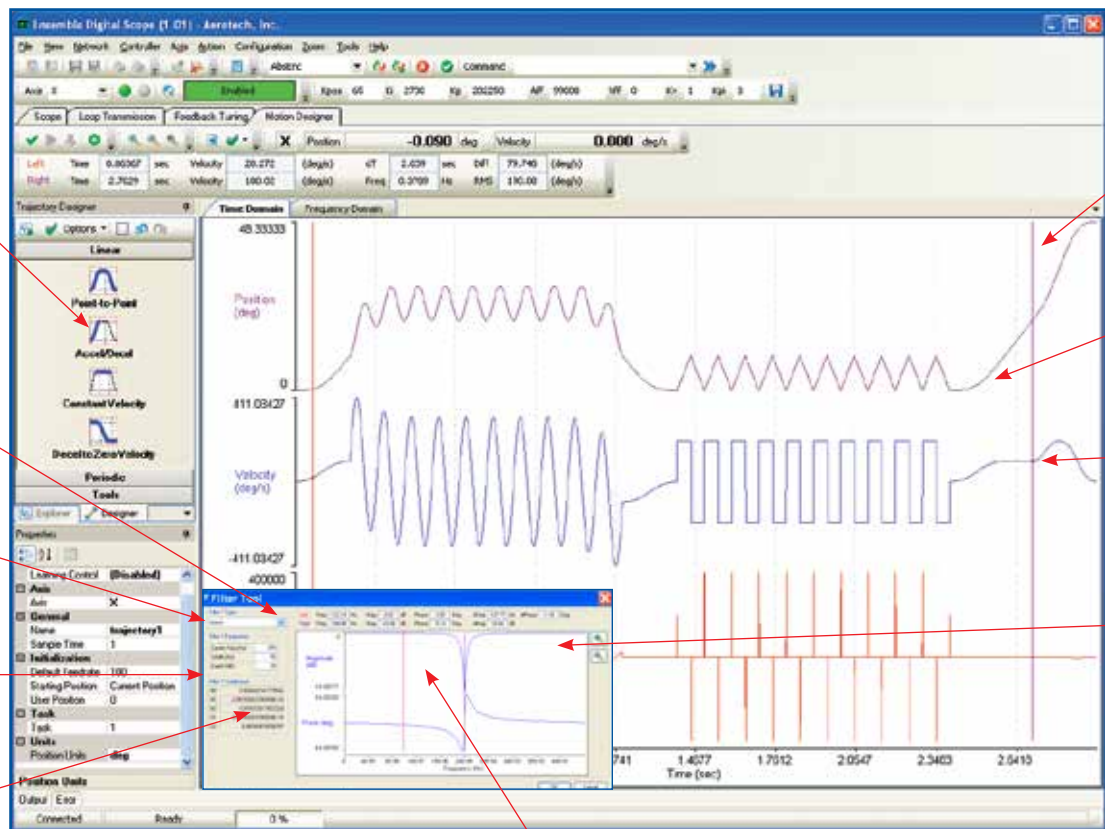

Cursor control

Apply filters to shape the trajectory frequency content

Import existing position, velocity or acceleration data

View the composite filter before applying to the trajectory

Cursor control

Automatic AeroBasic™ program generation for all controllers

Project tree for simple organization

Trajectory properties (e.g., user units)

Automatically calculates missing state information (e.g., acceleration, velocity or position)

Create periodic motion

Point-to-point moves

Overlay multiple trials for easy comparison

Easily modify an existing trajectory

Rapid motion programming

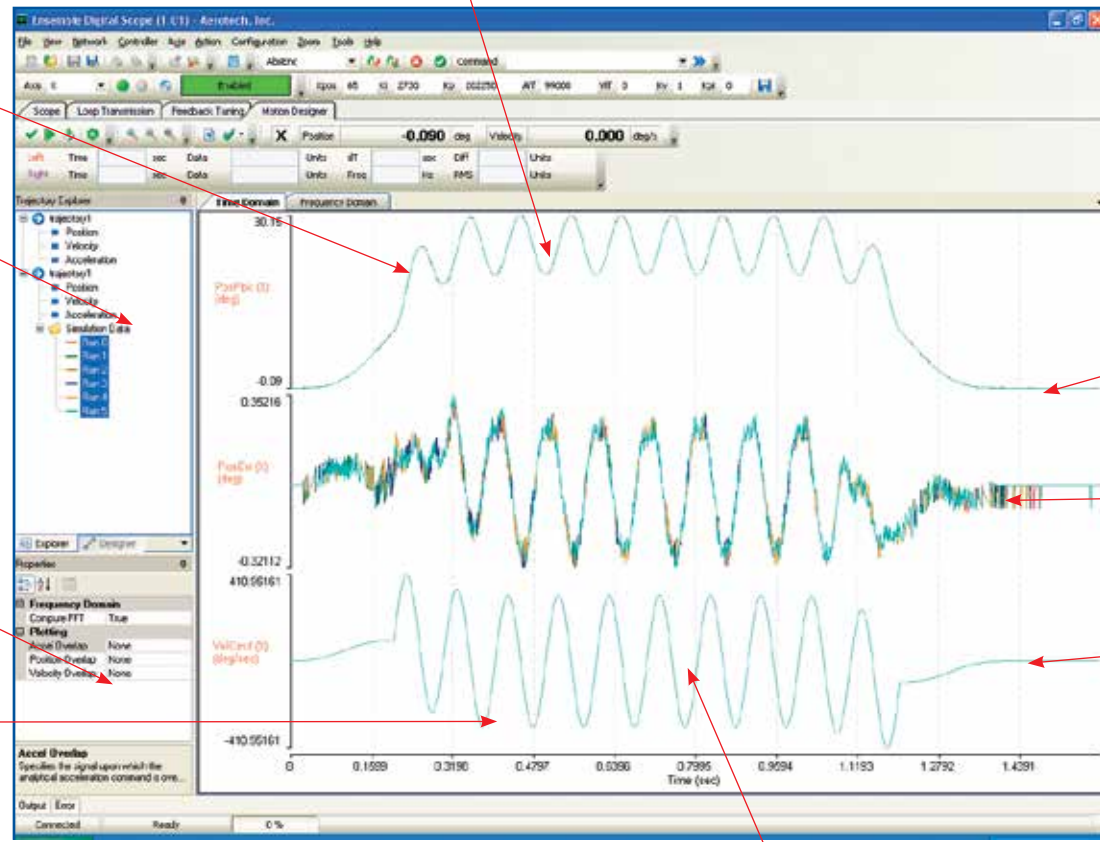

- **Operate 1,2,3 axis motion simulators**
- **Frequency response mode allows input sine sweep and UUT performance tests on customer device**
- **Harmonic Cancellation optimizes motion position errors generated by sinusoidal motion**

Aerotech Motion Simulator – The Integrated, Easy to Use, Graphical Trajectory Generation, Data Analysis and Enhanced Machine Performance Toolkit

Aerotech's Motion Simulator software is an easy-to-use Windows®-based program for creating simple and advanced motion stimuli for testing and calibrating inertial sensors and systems. The Aerotech Motion Simulator software includes all controls for manually or automatically running 1-3 axis motion simulations. The GUI provides a user interface and programming environment that requires no third-party development software.

Key Features:

- User-friendly Windows®-based graphical user interface
- Trajectory tracking from Ethernet, analog or Windows® program inputs
- Iterative Learning minimizes position error
- Overlap multiple runs of a trajectory to easily see how program changes modify the motion
- Perform data analysis such as FFT, max, min, average, rms and standard deviation from an existing trajectory for diagnosing system performance
- Data input file formats include Excel, CSV or MATLAB®; Motion Simulator can calculate the missing state variables



Main Screen

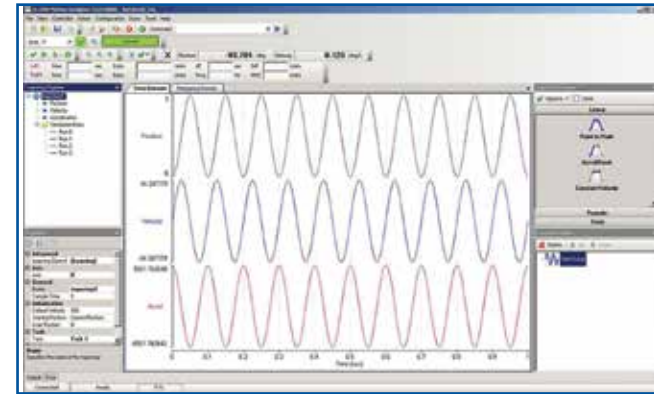

Motion Designer

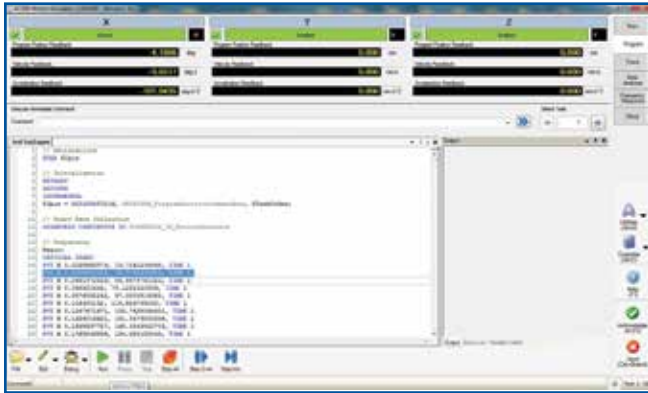

Program

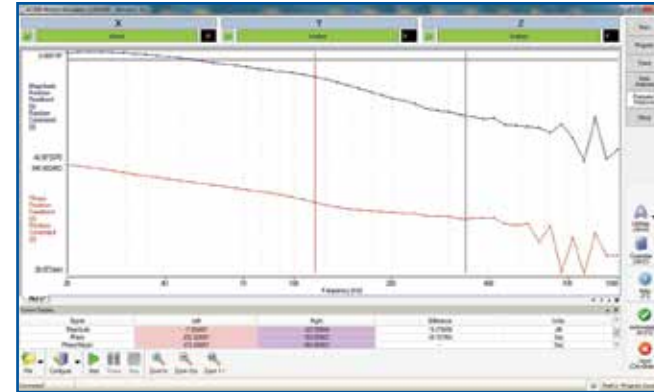

Frequency Response

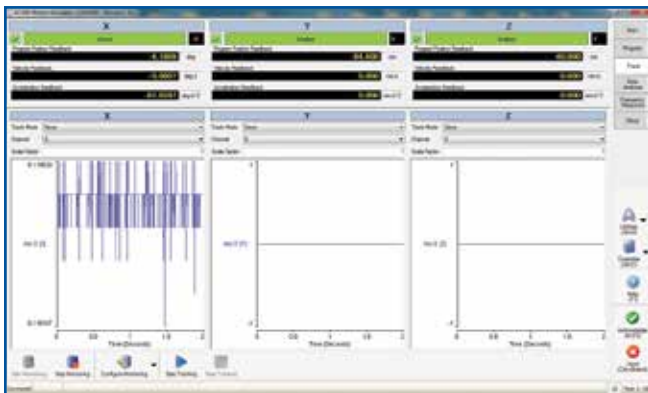

Track screen allows external signal selection for tracking

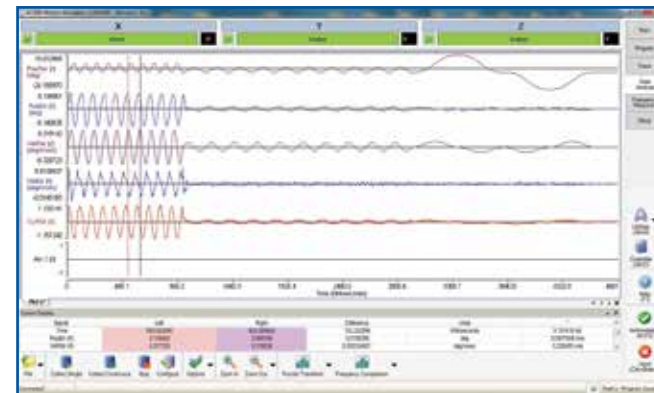

Data Analysis

Generate Motion Programs Directly From Your CAD Drawing

- Easily imports vector-based drawing files and produces G-code motion programs
- Interactive canvas allows easy editing and creation of new shapes and text
- Automatic and manual shape re-ordering options allow for optimal tool and processing paths
- Export to RS-274D G-code format
- Allows user-defined initialization, process shutdown, and shuttering commands (tool on/off)
- Offers seamless use of Aerotech's powerful controller features such as PSO (Position Synchronized Output)

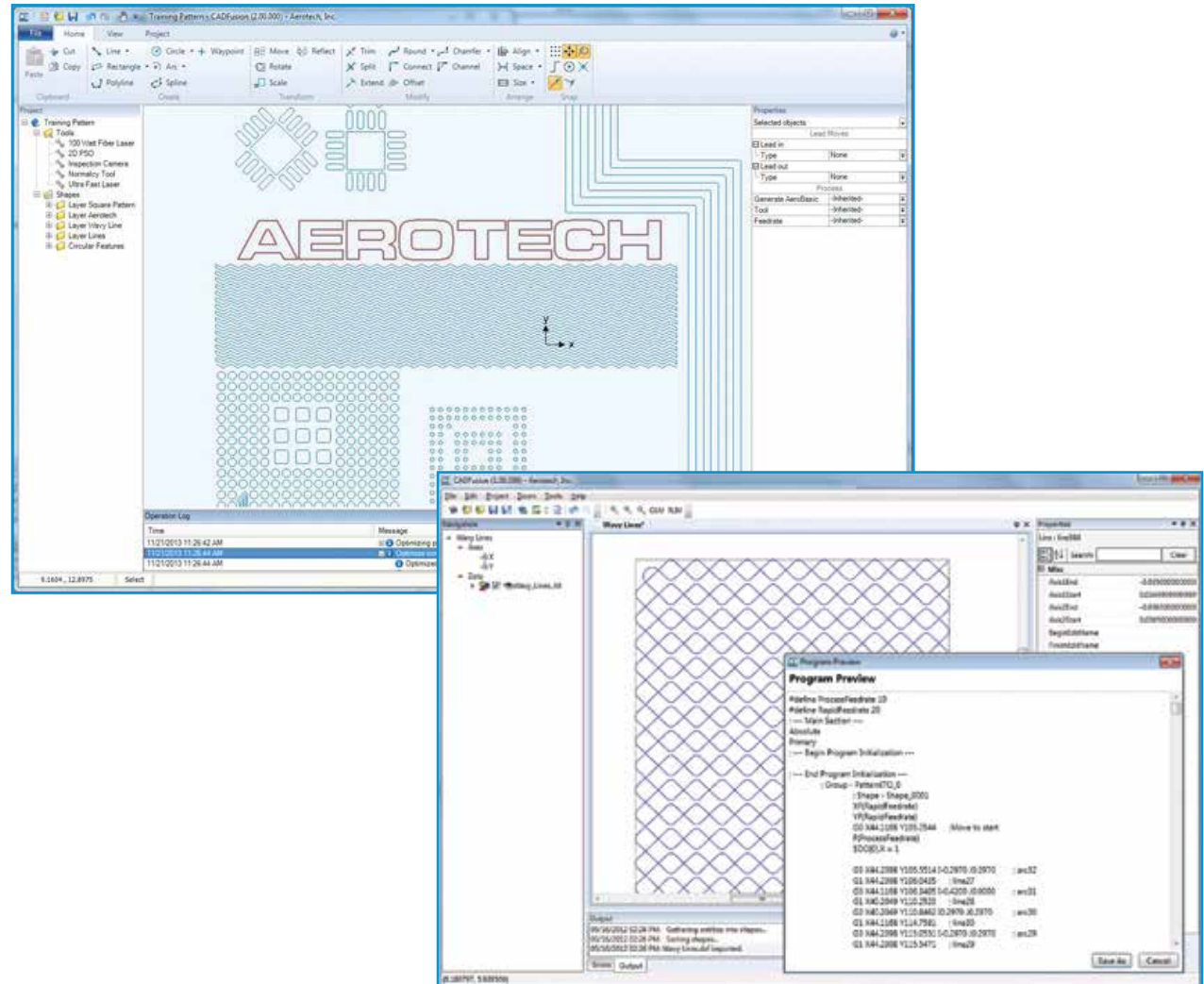

Open Simulation Environment

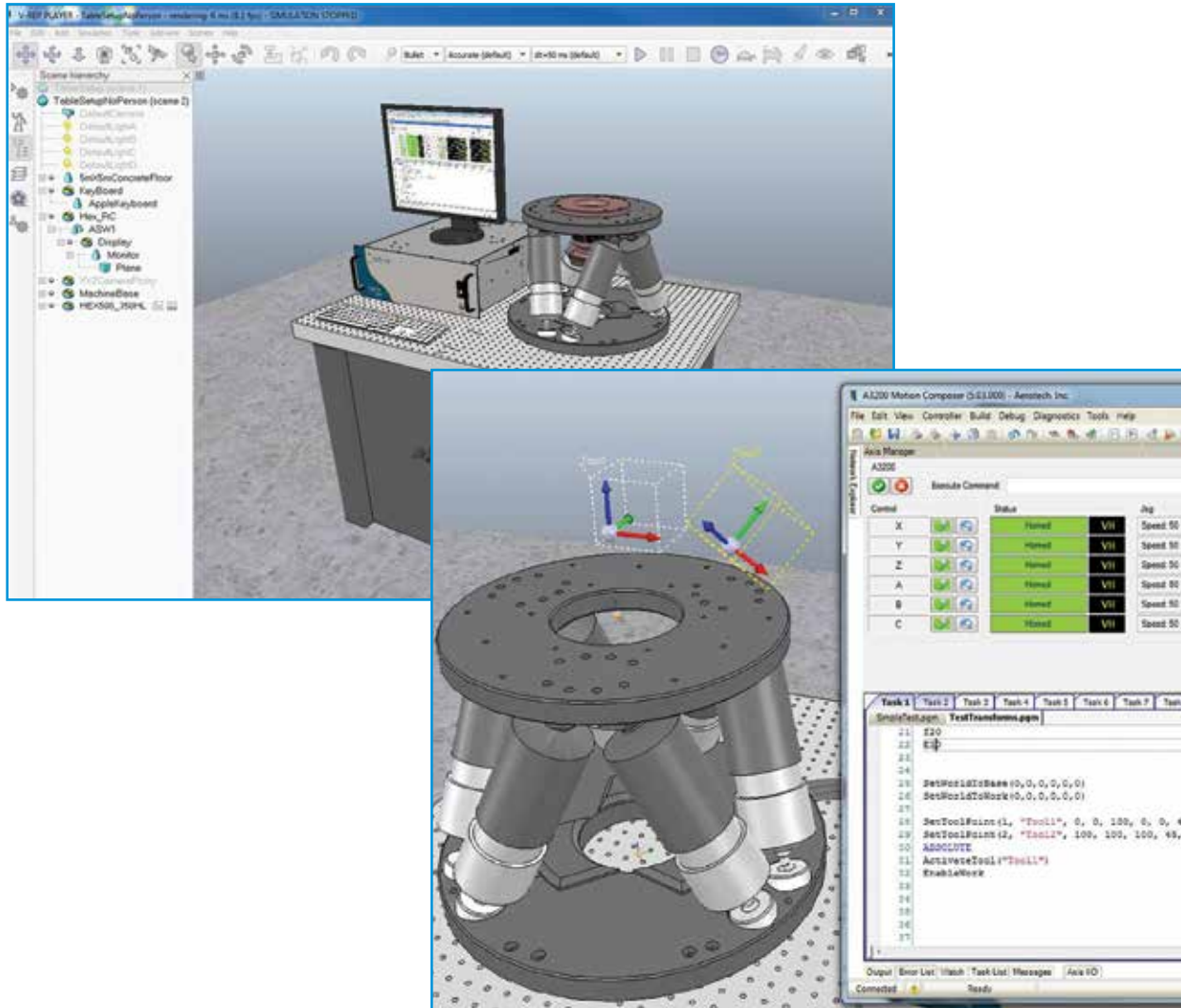

- Support for Coppelia Robotics virtual robot experimentation platform (V-REP)
- Full system modeling capability
- Visualization and selection of coordinate systems for multi-DOF systems like hexapods
- Pre-configured models connect directly to Aerotech's A3200 motion controller
- Import custom objects as 3D mesh files
- Supports collision detection between all elements in the environment
- Control grippers and vacuum pickup devices with Aerotech I/O

- Use the Aerotech Operator Interface (OI) for fast deployment
- Customize the OI to suit the application
- User customizable buttons that can execute standard G-code and AeroBasic™

Configurable Operator Interface

The screenshot shows the Aerotech A3200 CNC Operator Interface software. The interface is divided into several sections:

- Issue immediate commands:** A section on the left with buttons for X, Y, Z, H, and A axes.
- Configurable axis manager:** A central table showing axis status and feedback data.
- Configurable jog pad:** A section with directional buttons (+X, -X, +Y, -Y, +Z, -Z, +A, -A) and velocity settings (Low, High).
- User customizable buttons:** A grid of buttons labeled "Enable 1" through "Enable 4" for each axis (X, Y, Z, U).
- Active program:** A text area showing the current G-code program being executed.
- Standard machine controls:** A row of icons for "Open", "Close", "Edit", "Cycle Start", "Feed Hold", and "Abort".
- Designed for touch screen:** The interface is designed with large, clear buttons and text for touch interaction.
- Set up simple or complex action — user can attach a standard G-code program to a button:** The customizable buttons allow users to assign specific G-code programs to them.

Axis	Position	Velocity	Feed
X	60.355	24.641	mm/s
Y	68.355	24.441	mm/s
Z	0.694	0.244	mm/s
H	68.355	24.441	mm/s
A	0.000	0.000	mm/s

Layered for flexibility • Customizable at many layers • Most cost-effective solution

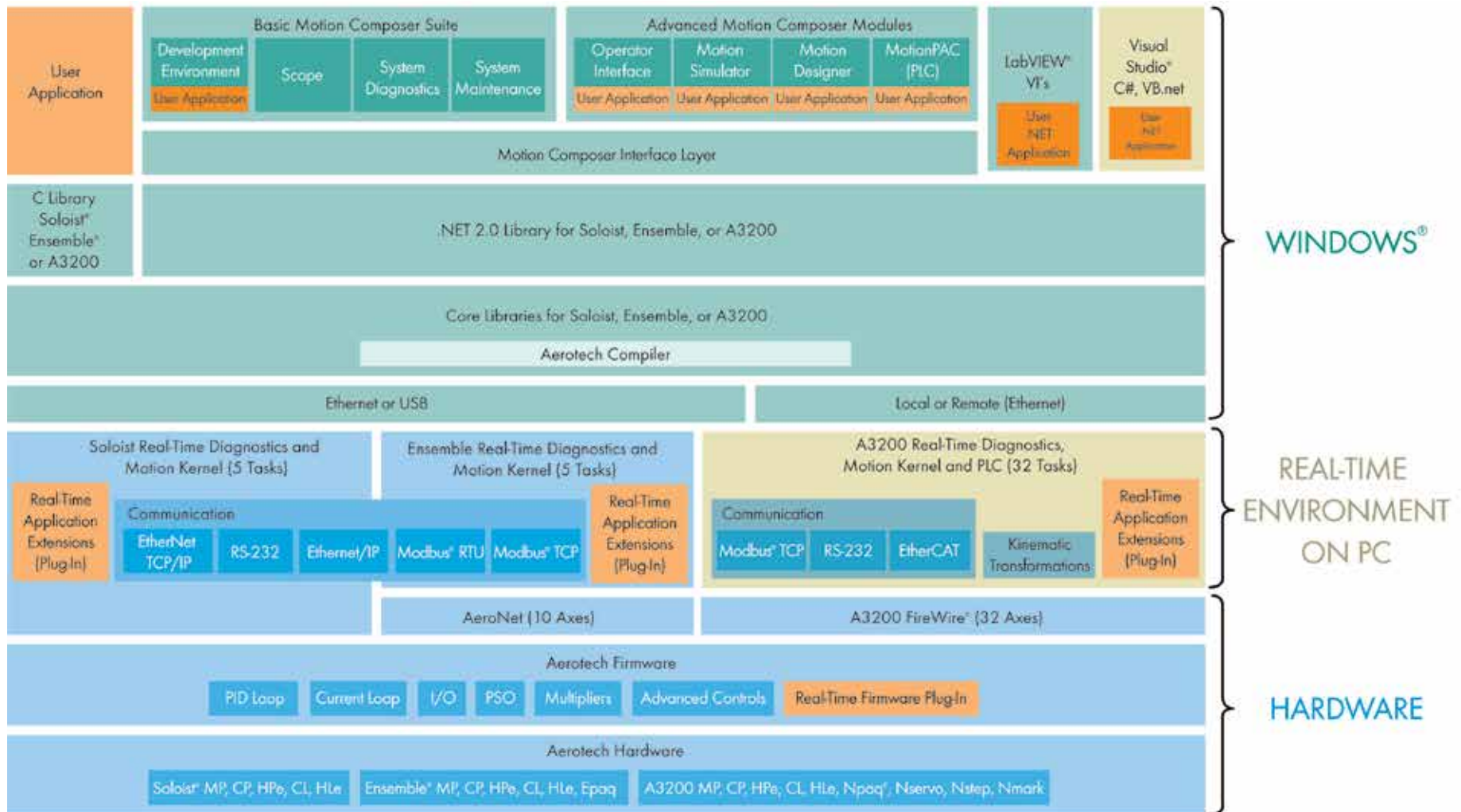



Digital Automation Platform

- Higher throughput due to high performance control, network and high-power drives
- Higher accuracy and repeatability due to all digital drives and advanced servo algorithms
- Faster startup and changeover results from fully integrated motion platform, easy-to-use setup tools and extensive diagnostics
- Lower startup and life-cycle cost due to less components and reduced engineering
- Higher reliability due to fewer components
- Simplified integration

Distributed Motion Control

- Motion trajectory generation and synchronization are centralized at the PC
- Motion execution is decentralized at the drives
- A3200 operates on any standard desktop or industrial PC
- Servo loops are closed on the drive

Use Nservo to Retrofit Existing Motors & Drives or Drive Large Motors

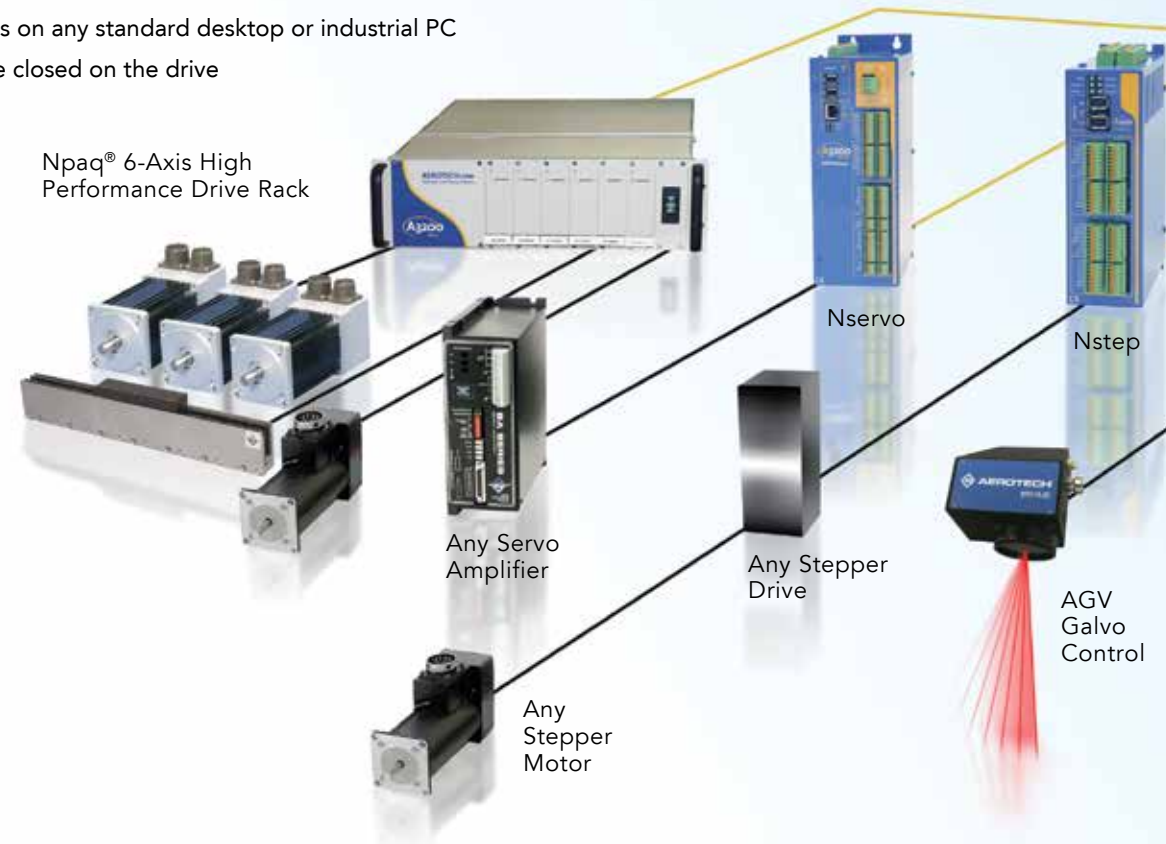

The Intelligent 32-Axis Motion, Vision, PLC, Robotics and I/O Platform

- Easily installed digital drives
- FireWire® (IEEE-1394) industry standard, high-performance motion bus

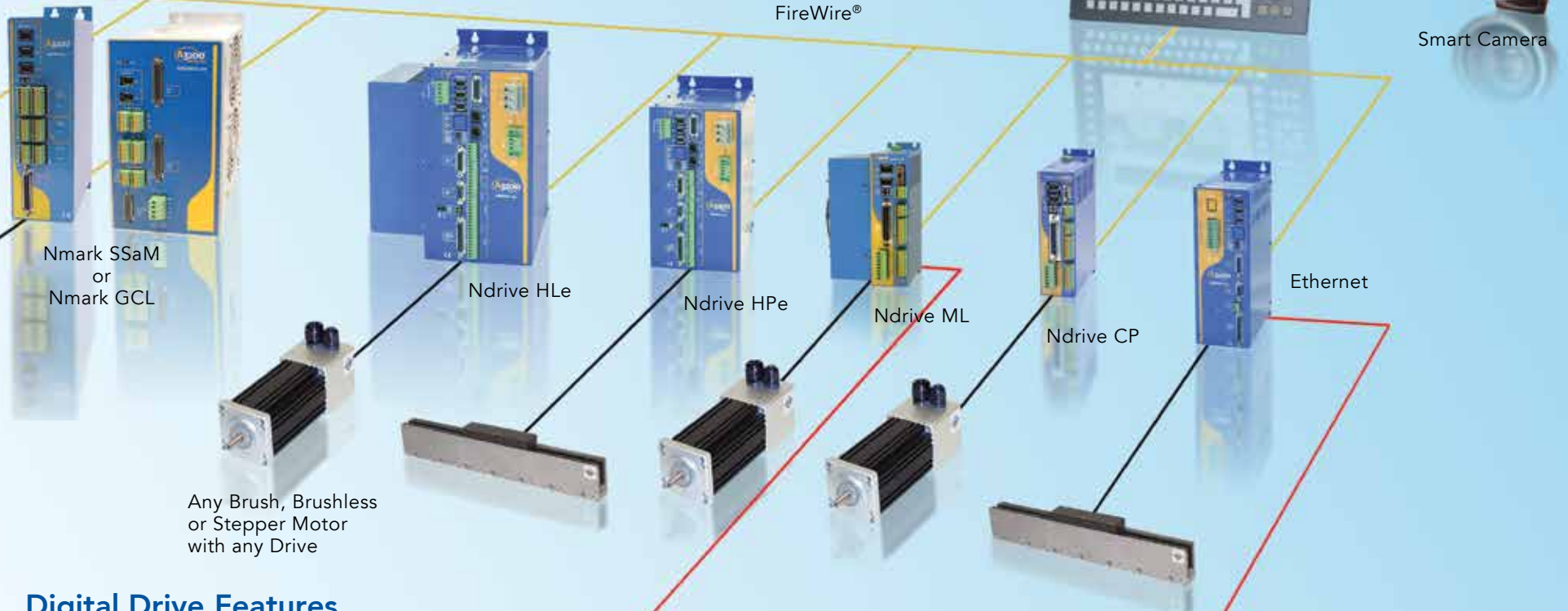

Digital Drive Features

- PWM or linear (10 A to 150 A peak)
- Integrated 10/100 Base-T Ethernet
- Encoder, resolver or inductosyn feedback
- Onboard x65536 encoder multiplication
- 20 kHz position, velocity and current-loop sample rate
- Integral power supply
- Sinusoidal commutation
- Local I/O ports



Easily integrates with Keyence LK-G Series Laser Displacement Sensors



Ethernet I/O Expansion
Analog and Discrete I/O

Stand-Alone Multi-Axis Automation Controller

Ensemble[®]

Stand-Alone Multi-Axis Automation Controller

- Easy to use
- Powerful architecture
- Distributed control
- Network ready

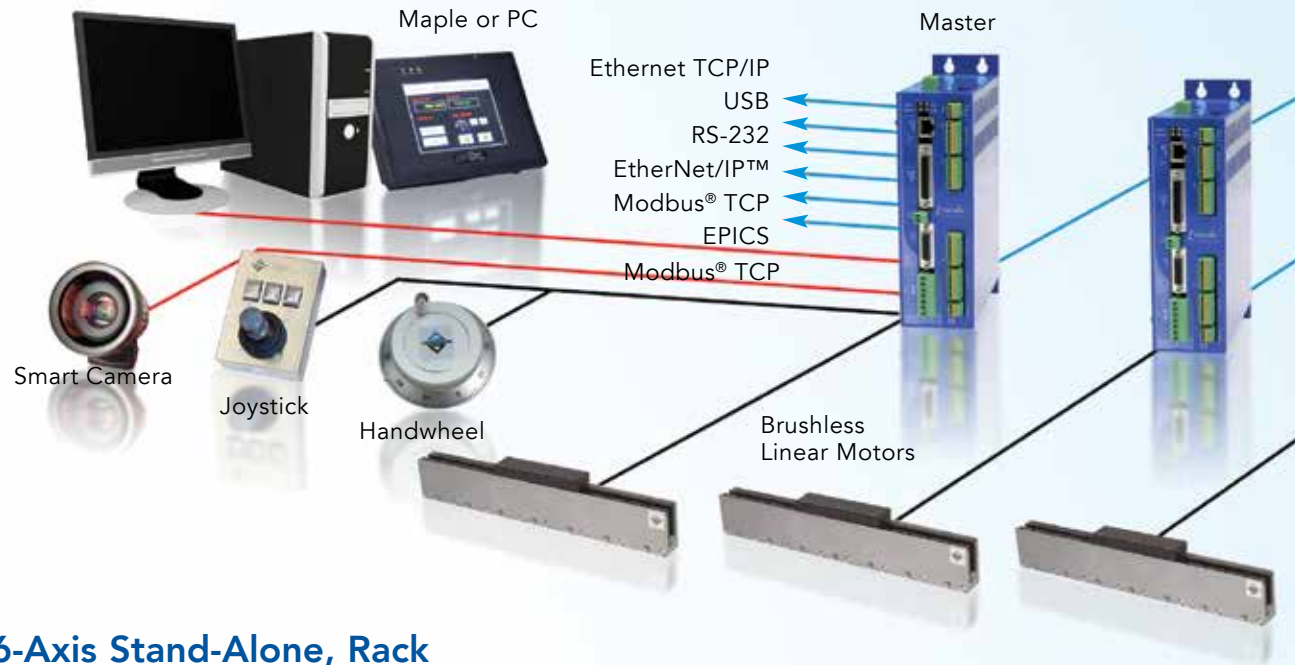

6-Axis Stand-Alone, Rack Mount or Desktop Plus Three Axes



Software, Controls, Drives and I/O... All in One Package

10-Axis, Stand-Alone, All Digital, Panel-Mount Controllers

from 10 to 150 A peak

AeroNet

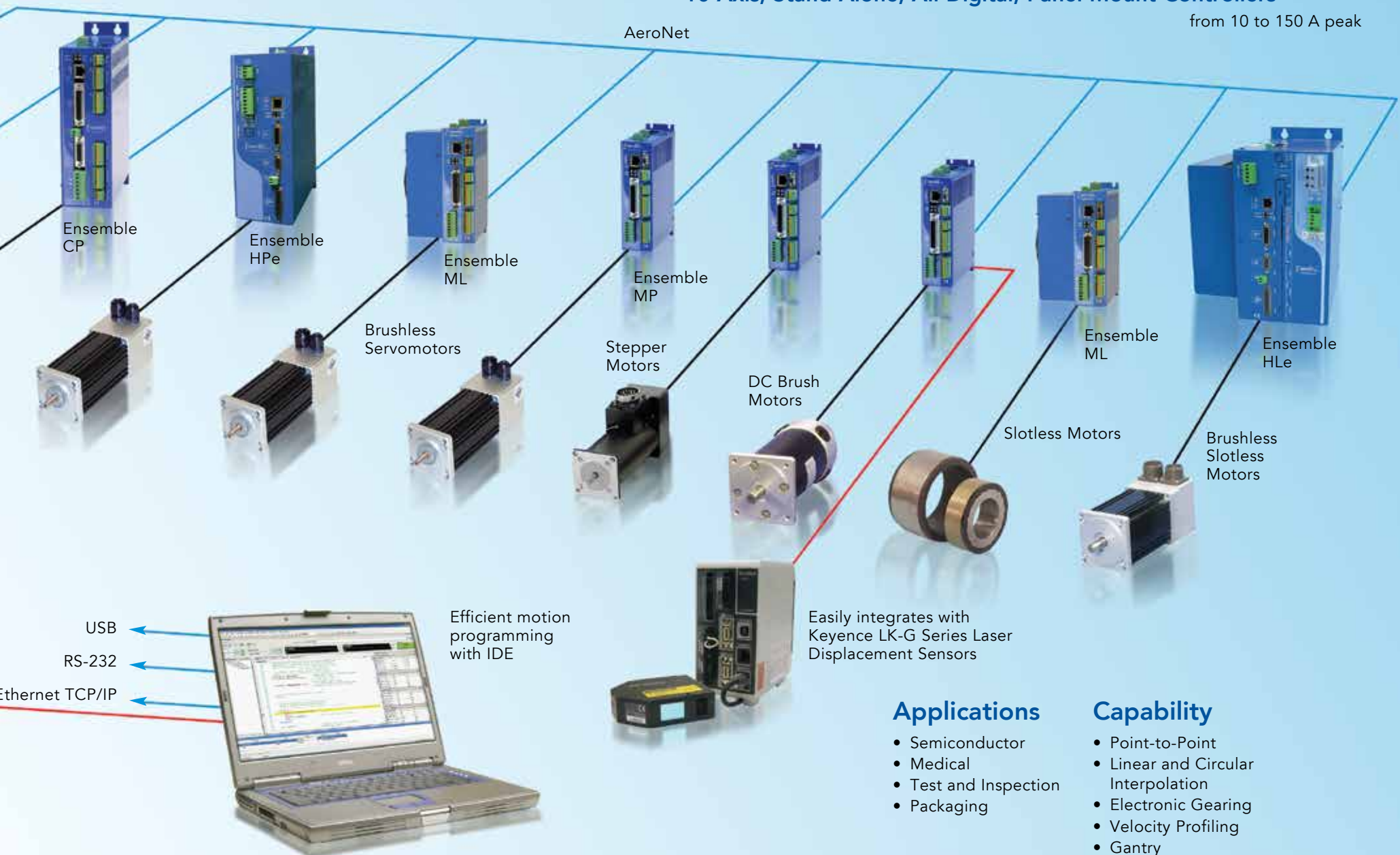

Efficient motion programming with IDE

Easily integrates with Keyence LK-G Series Laser Displacement Sensors

Applications

- Semiconductor
- Medical
- Test and Inspection
- Packaging

Capability

- Point-to-Point
- Linear and Circular Interpolation
- Electronic Gearing
- Velocity Profiling
- Gantry

Stand-Alone Single-Axis Automation Controller

Soloist[®]

Stand-Alone Single-Axis Automation Controller

- Easy to use
- Scalable
- Ethernet/USB connectivity

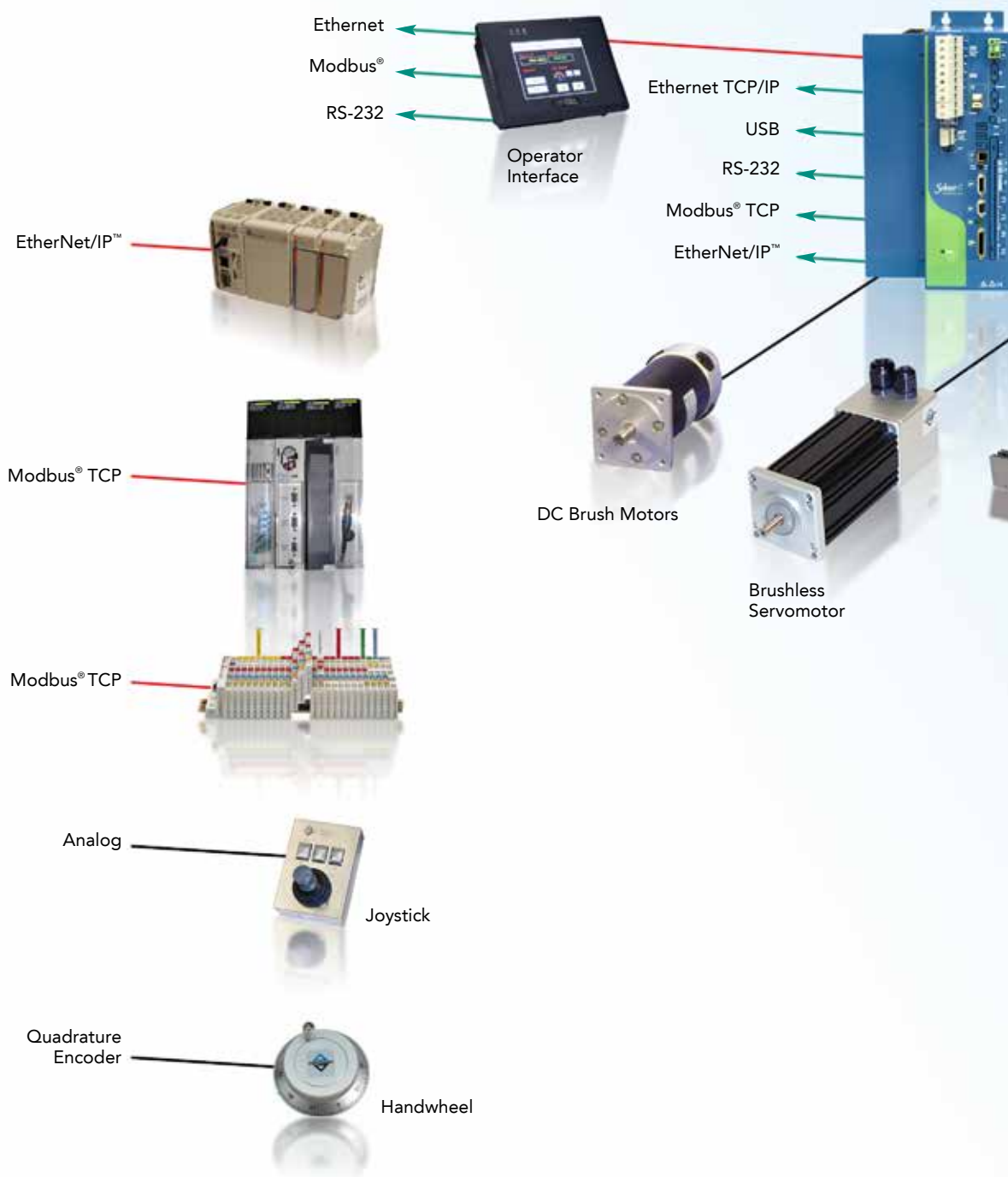

Software, Controls, Drives and I/O in One Compact Package

from 10 to 150 A peak

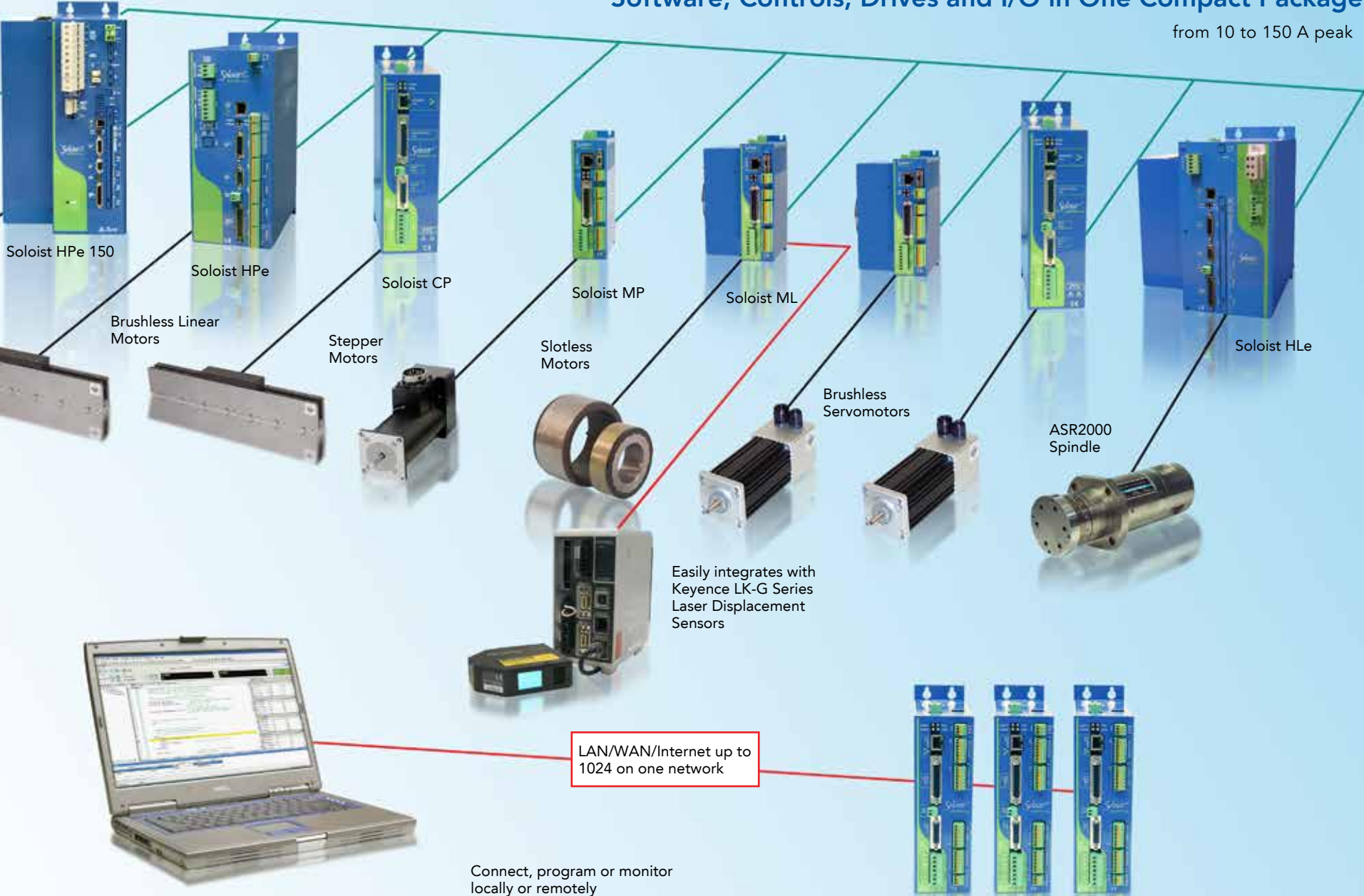

Controller and Drive Technology

MP for OEMs lowers costs • CP solutions for less integration work • HPe for the highest performance solution

Ndrive® MP Ensemble® MP Soloist® MP

Width: 41.1 mm
Height: 141.2 mm

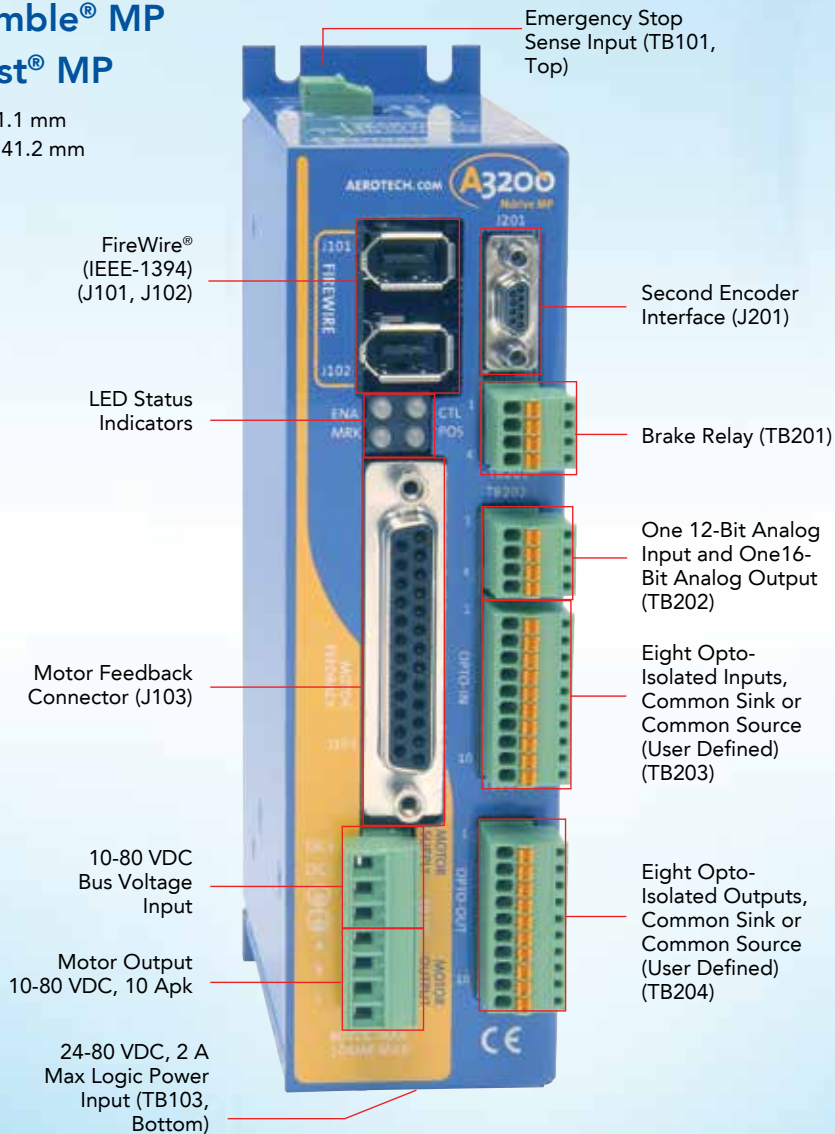

Ndrive® CP Ensemble® CP Soloist® CP

Width: 63.5 mm
Height: 198.2 mm

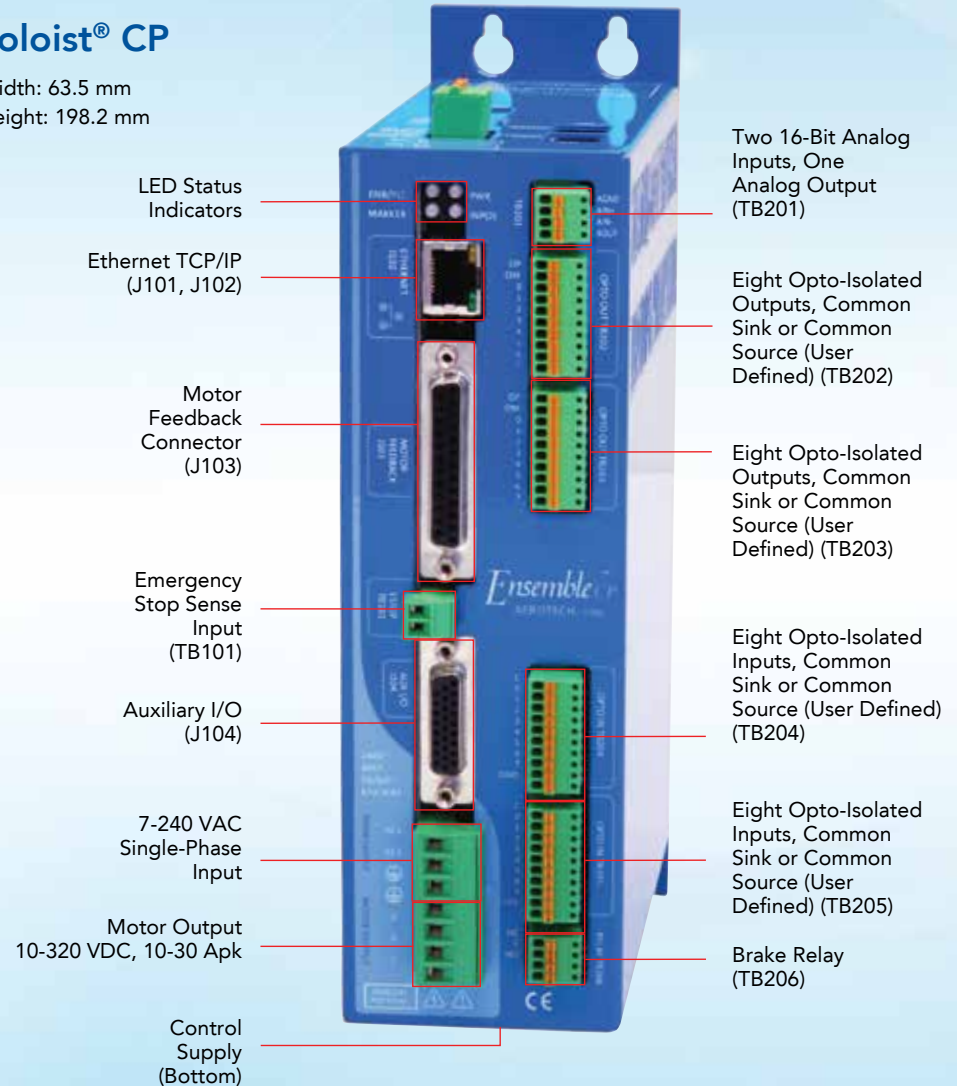

Ndrive® HPe
Ensemble® HPe
Soloist® HPe

Width: 99.1 mm
 Height: 232.5 mm

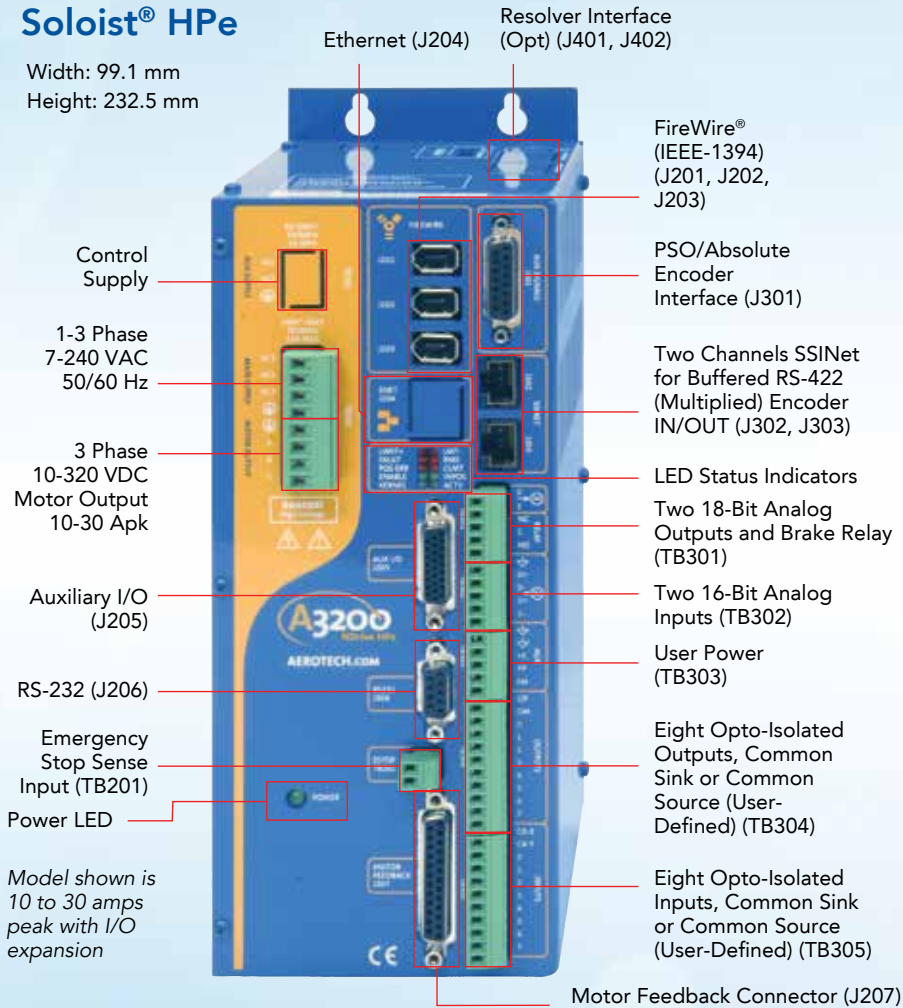

Ndrive® HPe
Ensemble® HPe
Soloist® HPe

Width: 212.6 mm
 Height: 234.8 mm

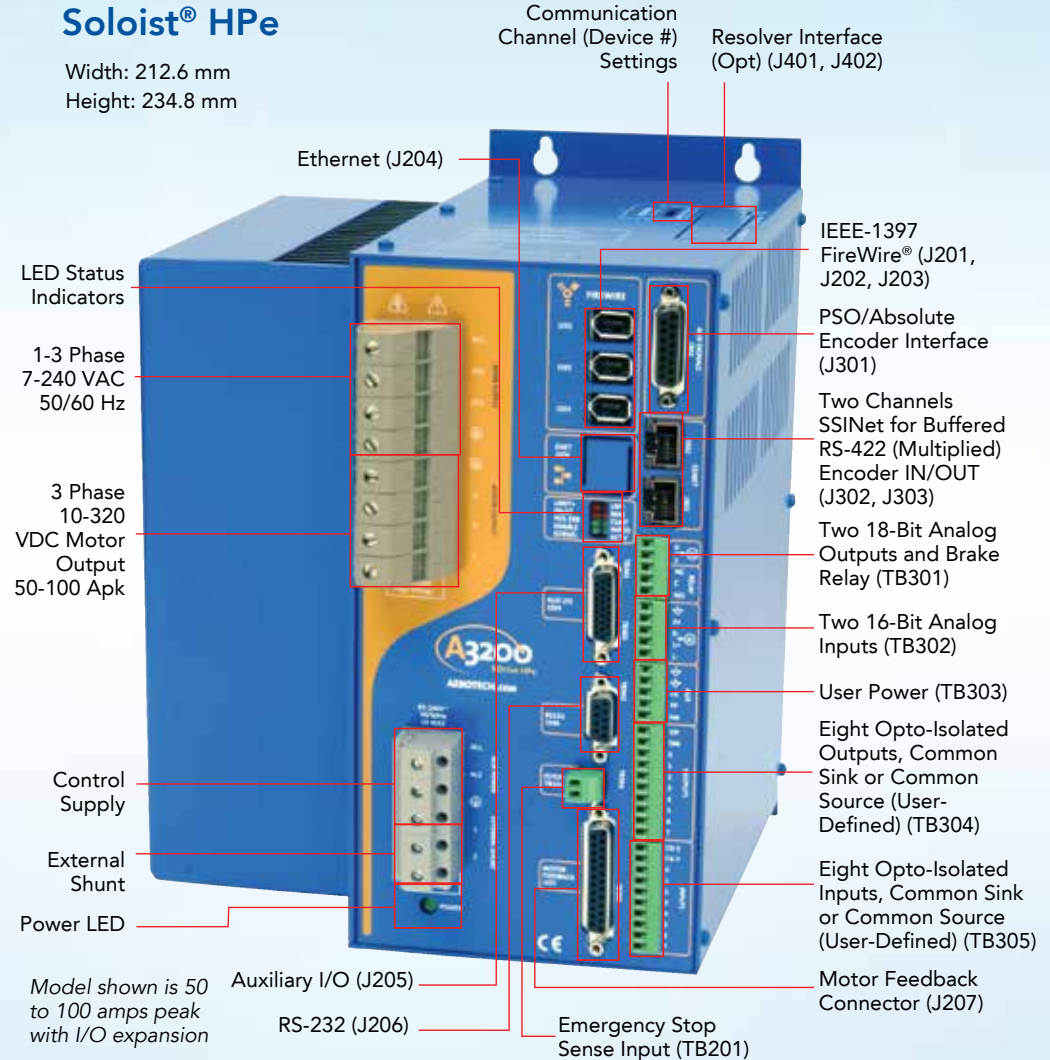

Controller and Drive Technology

Linear Drive Advantages

- Ultra-smooth motion during reversals
- Superior in-position stability
- Integrated with controls
- No switching noise
- No dead band
- Low EMI

Applications

- Nondestructive testing
- Stencil cutting
- Any small move, or sinusoidal movements
- Very slow velocity applications
- Stent manufacturing
- Target tracking
- Piezo stages

Ndrive® HPe150 Ensemble® HPe150 Soloist® HPe150

Width: 229.7 mm
Height: 406.1 mm

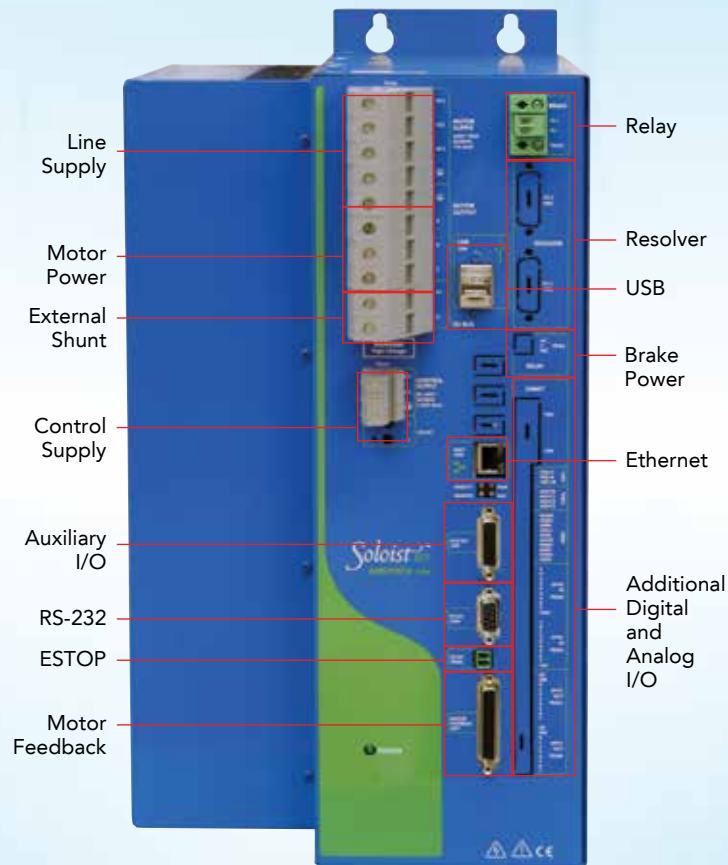

Ndrive® ML Ensemble® ML Soloist® ML

Width: 41.1 mm
Height: 141.2 mm

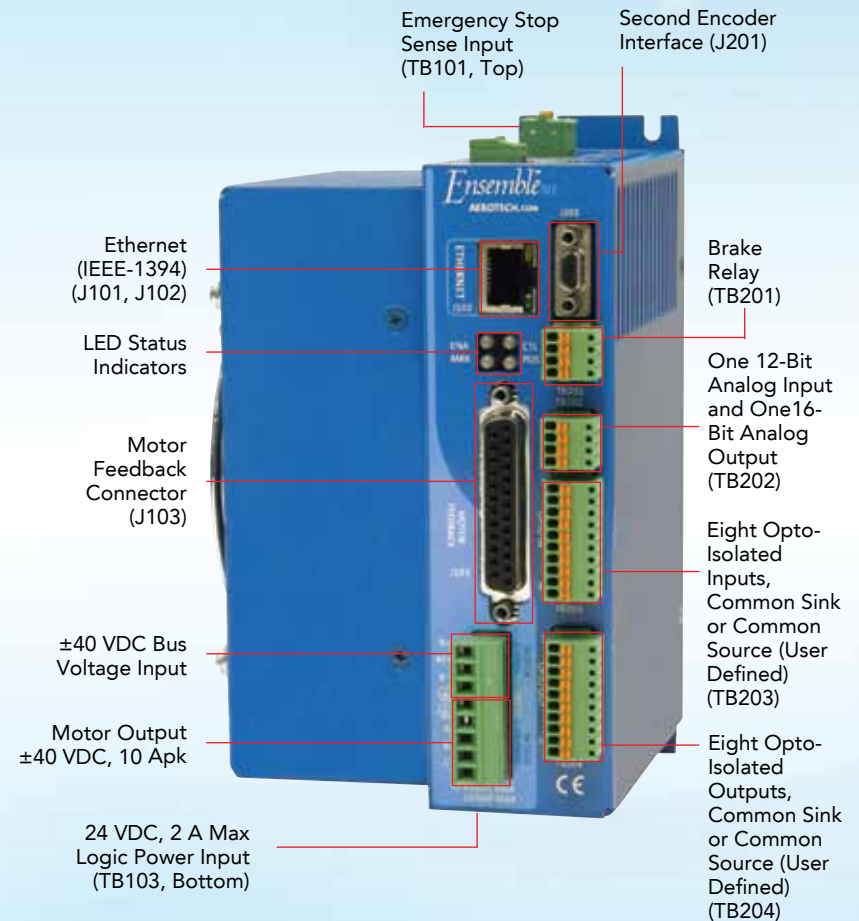

Ndrive® HLe Ensemble® HLe Soloist® HLe

Width: 206.9 mm
Height: 234.3 mm

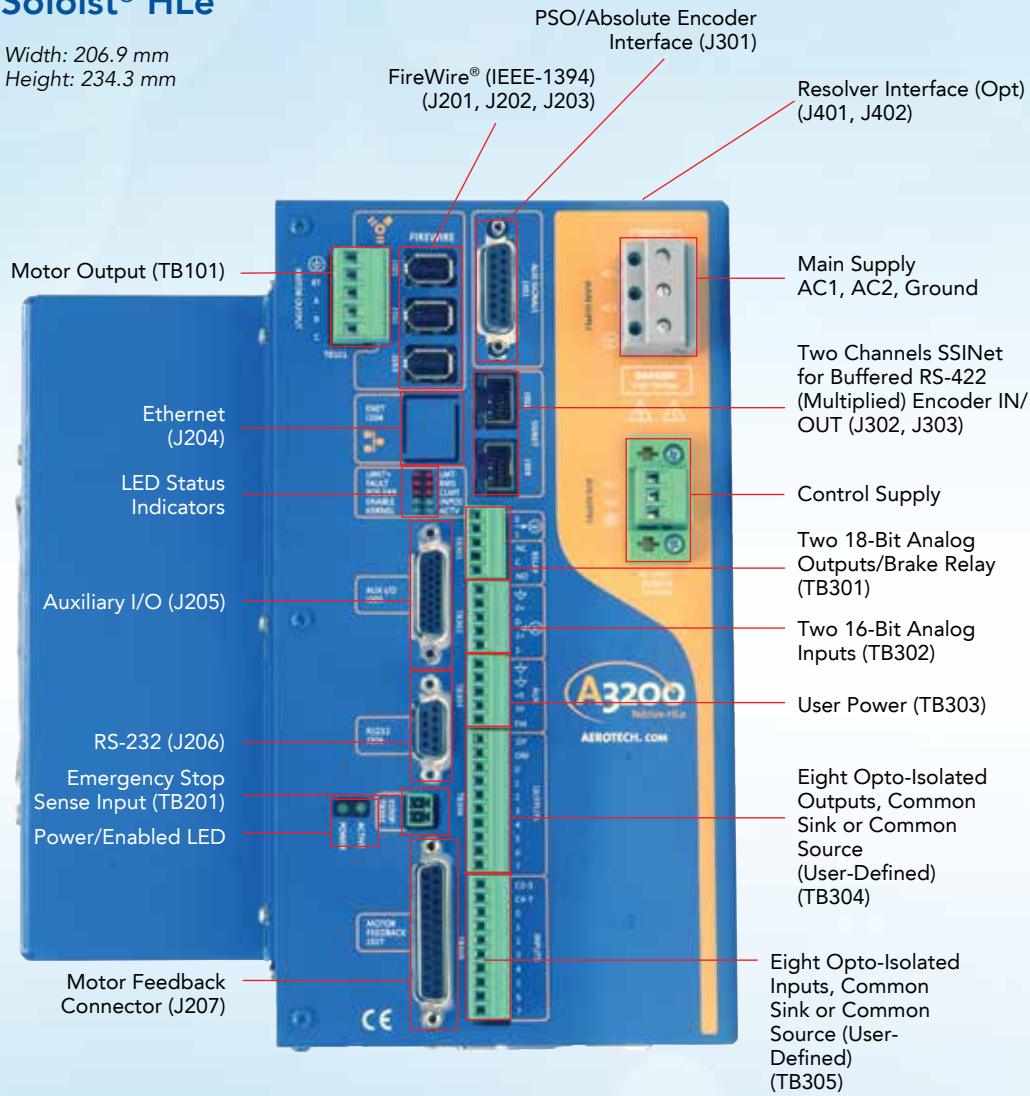

Nstep

Width: 49.2 mm
Height: 161.8 mm

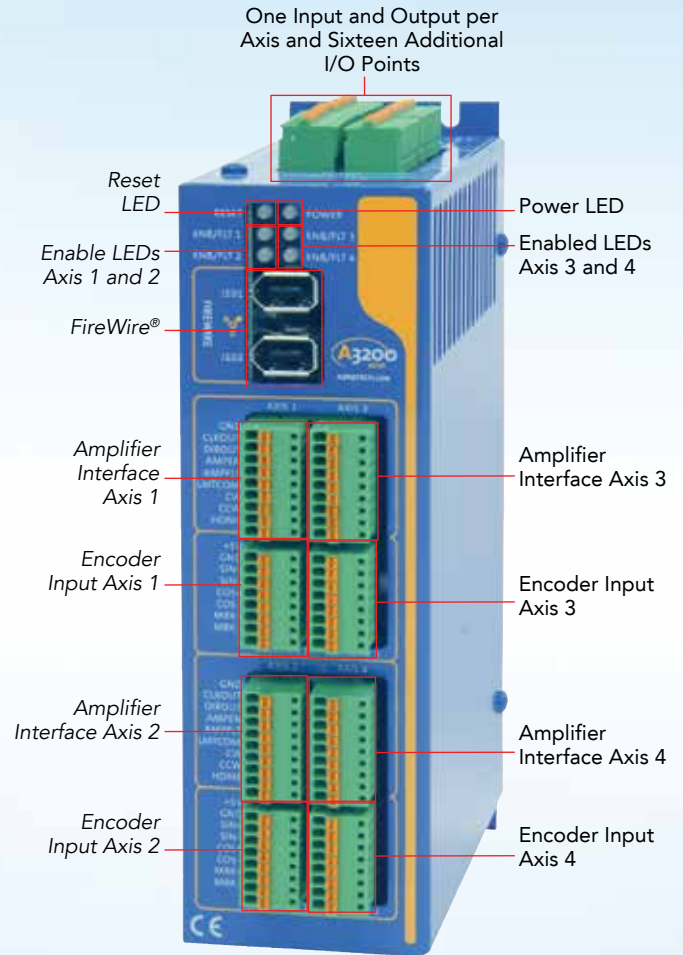

Controller and Drive Technology

Nmark® CLS

Width: 90.5 mm
Height: 210.8 mm



Nmark® SSaM

Width: 63.7 mm
Height: 199.0 mm

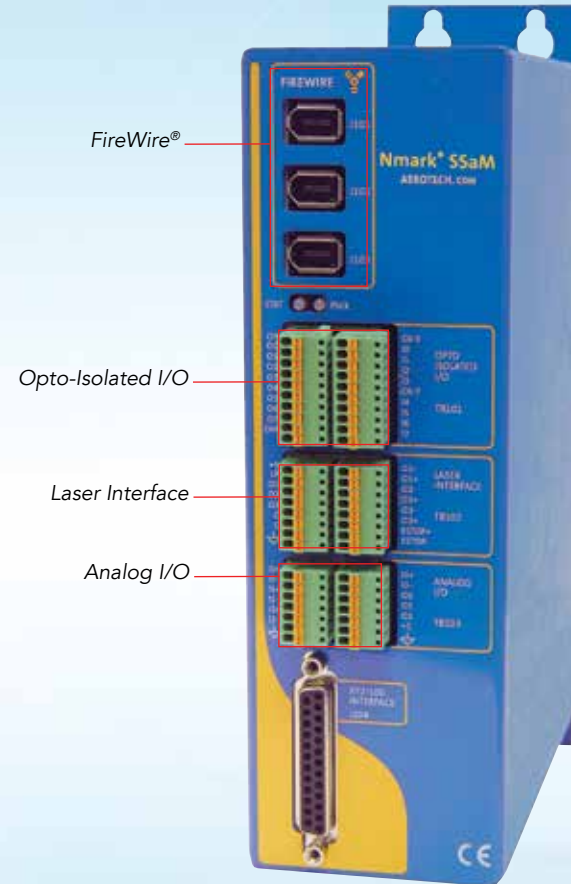

Nservo

Width: 87.6 mm
Height: 230.4 mm

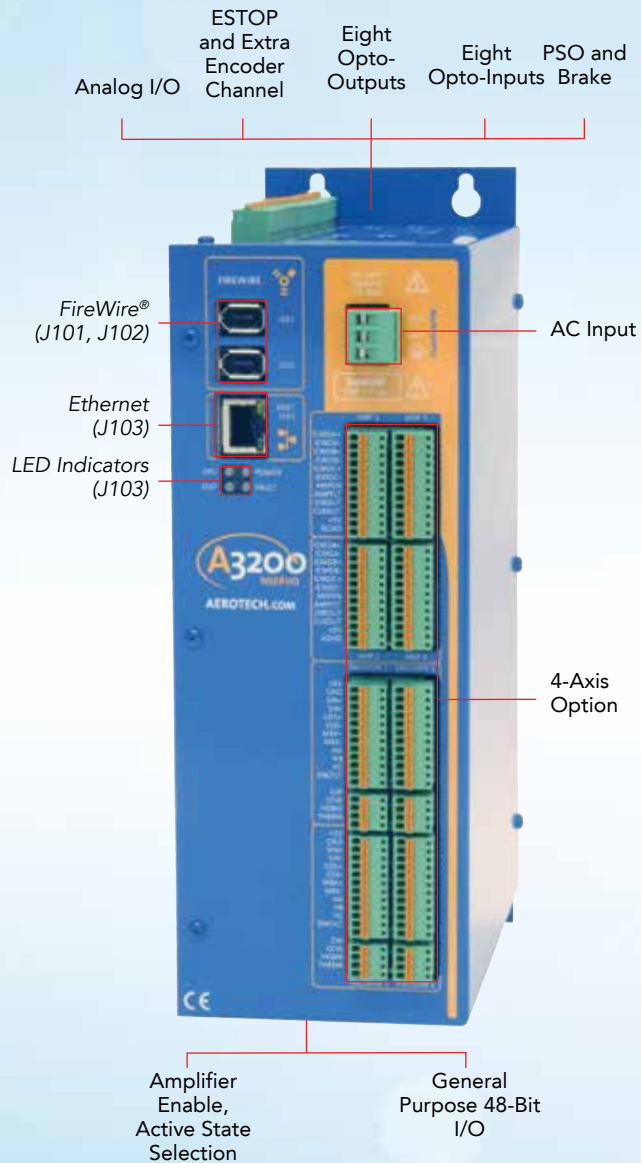

Nservo – OEM

4 Axis or Less
Width: 284.5 mm
Height: 276.9 mm

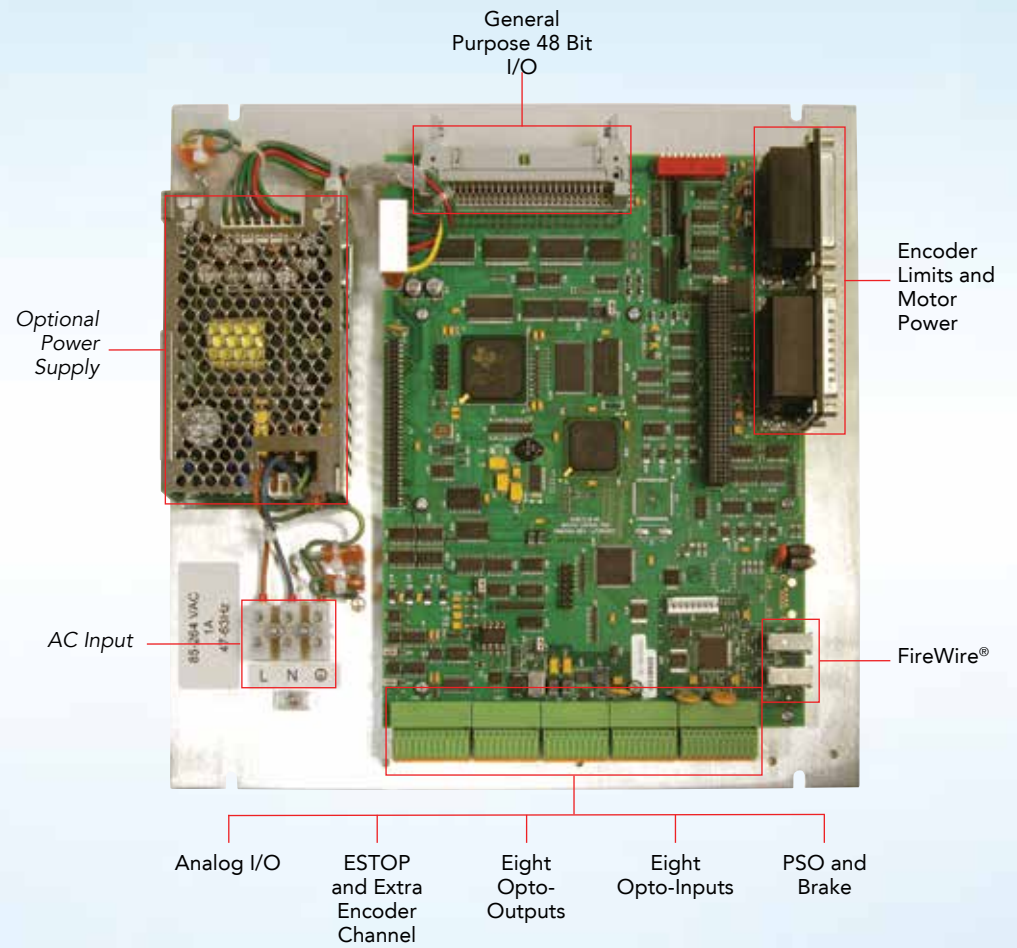

Controller and Drive Technology

Npaq® and Epaq Rack Mount or Desktop Solutions in One Box Minimize Wiring

Console



Npaq®

6 Axis or Less
Width: 436.7 mm
Height: 132.0 mm

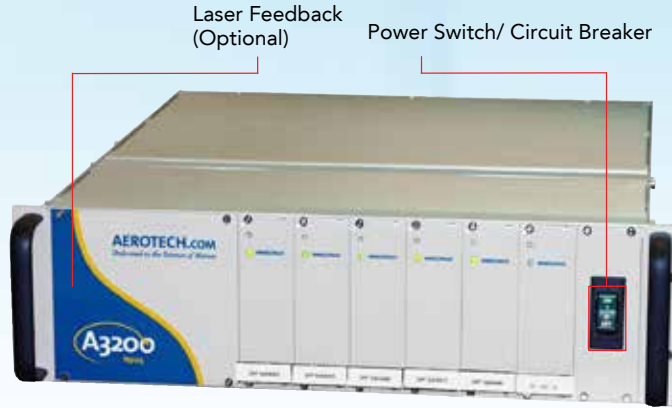

Npaq® MR/Epaq MR

8 Axis or Less
Width: 436.7 mm
Height: 132.0 mm

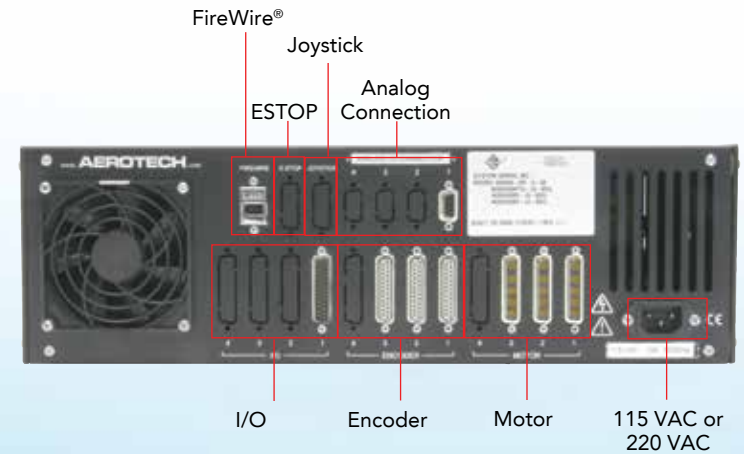
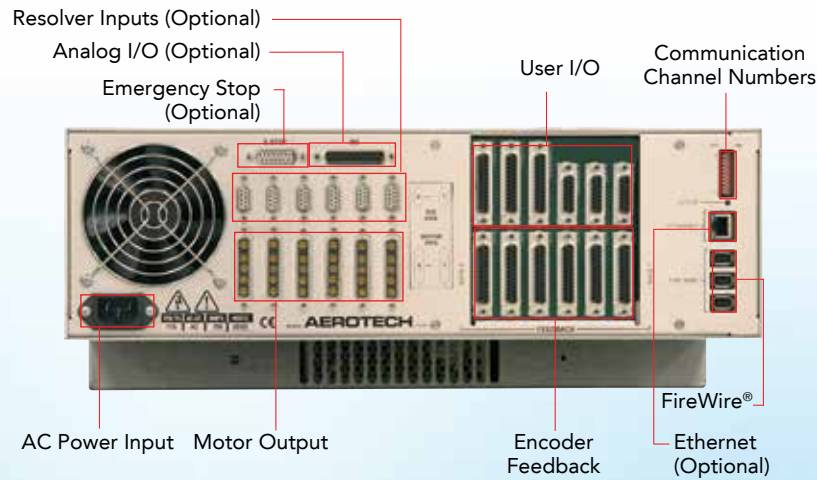
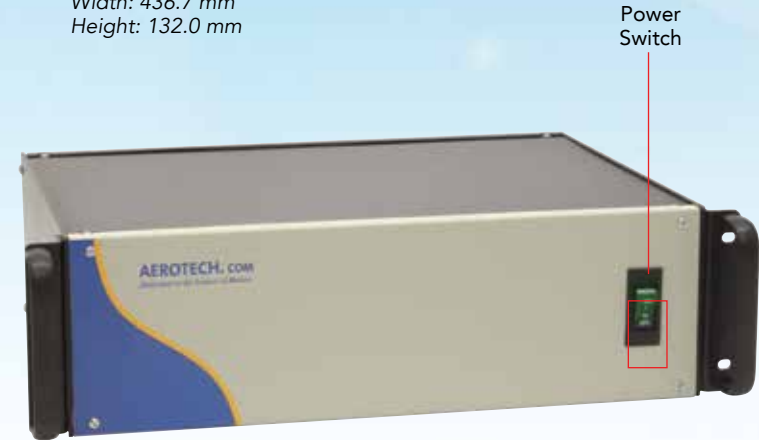

Ensemble® Epaq

5 Axis or Less
 Width: 431.8 mm
 Height: 177.8 mm

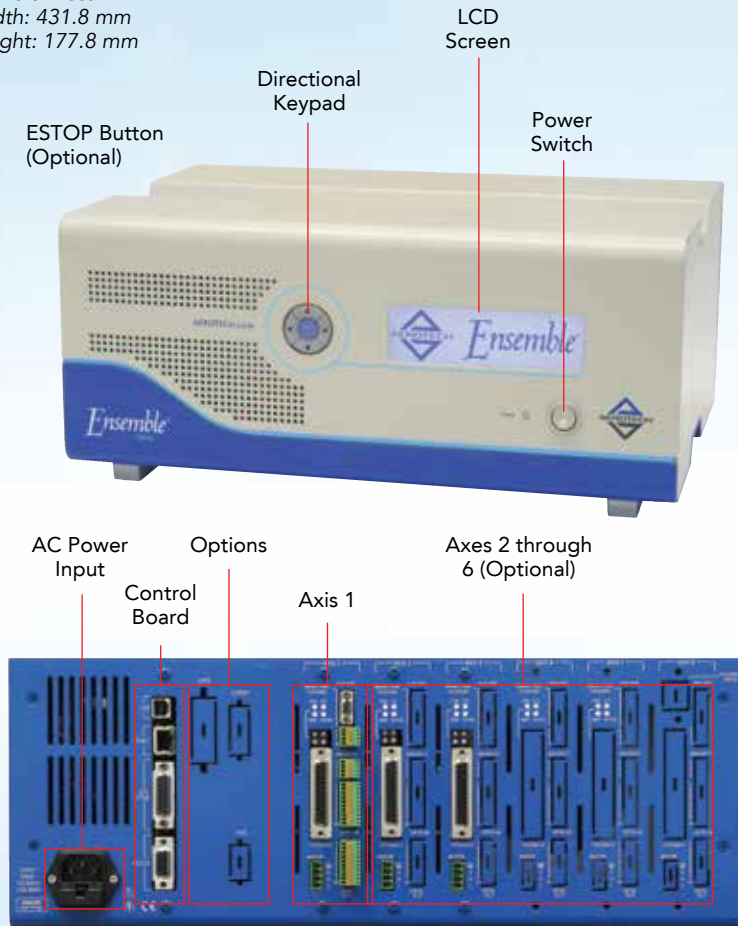

Ensemble® LAB

4 Axis or Less
 Width: 370.2 mm
 Height: 98.4 mm

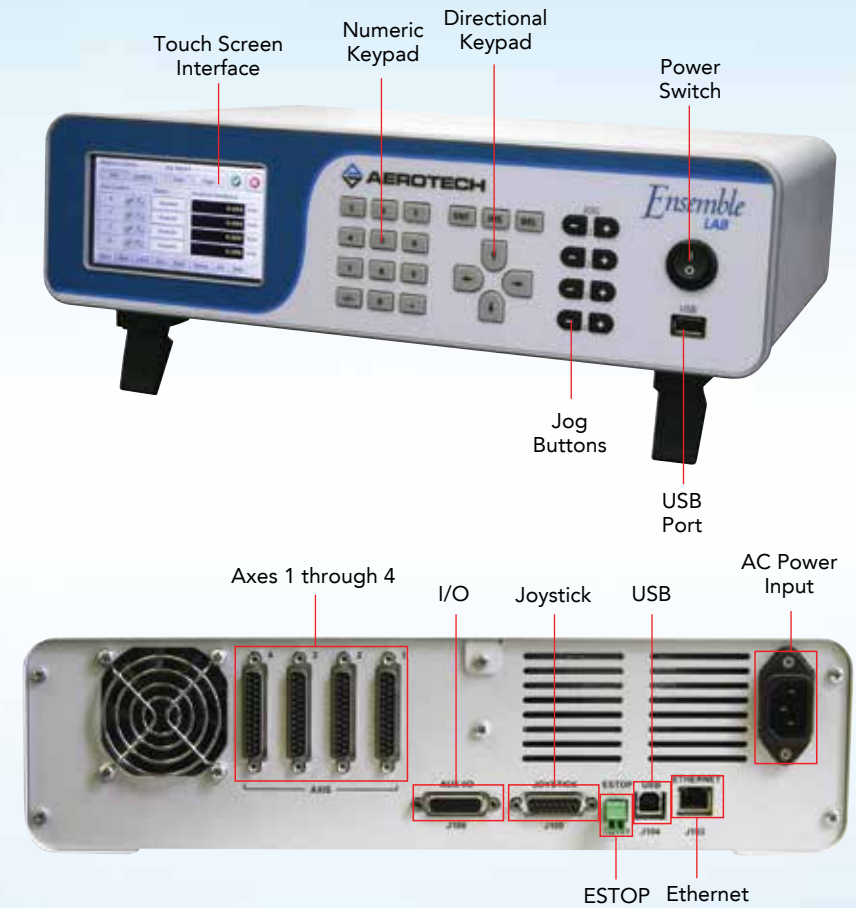

Standard Control Capabilities

Aerotech controllers offer the broadest array of programming interfaces and core motion capabilities of any automation system available today. Aerotech controllers have the programming flexibility and capability to meet the requirements of the most demanding motion applications of OEMs and end-users alike.

Point-to-Point Motion

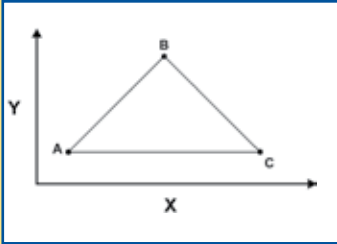

Basic independent axis positioning with programmable accel/decel and feedrate.

Acceleration Limiting

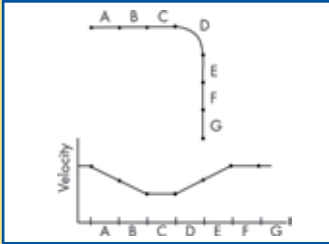

Anticipate sharp corners and small radius arcs and automatically decelerate as needed.

Coordinated Motion

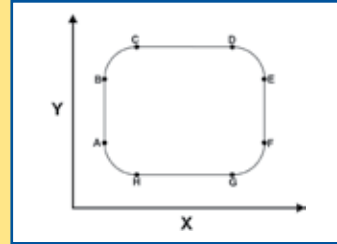

Linear and circular motions are supported in all languages.

Arbitrary Path Generation (PVT)

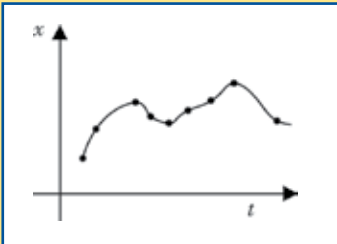

Specify discrete position, velocity and time and the controller will interpolate to create a smooth, contiguous path.

Electronic Gearing

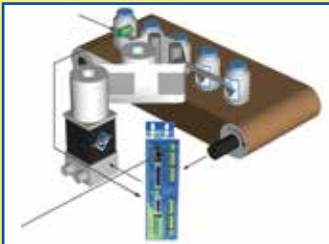

Electronically control one axis as a simple ratio or as a complex function of another axis; fire I/O in real time during a move.

On the Fly End-Point Modification

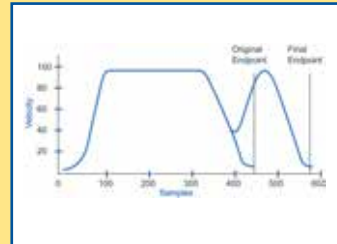

Modify the endpoint during execution of the motion profile.

Cutter Compensation

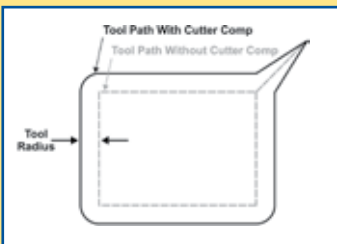

Also known as tool radius compensation, this feature automatically adjusts the path to allow for the radius of a cutting tool.

Parts Rotation

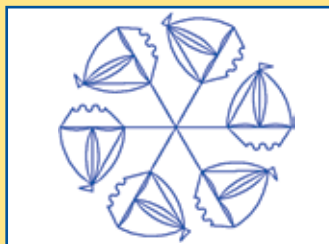

Use when a two-dimensional part must be repeated in different orientations without translating the part program many times over.

Velocity Profiling

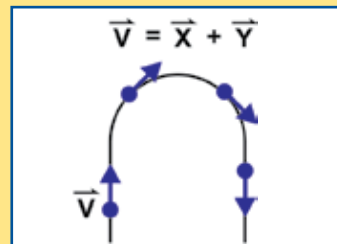

Maintains a constant vector velocity along the programmed path.

Seven Segment Acceleration

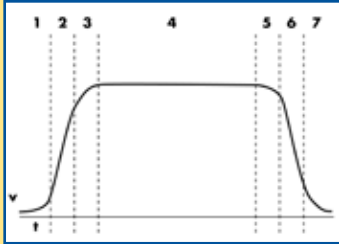

Specify the acceleration profile in seven segments, providing precise control over system motion.

Velocity Blending

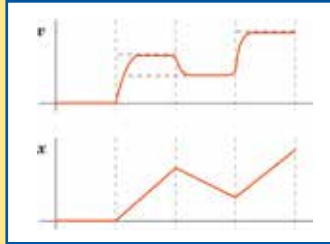

The velocity changes to the next velocity command, acceleration limited, without stopping.

Fast Position Capture

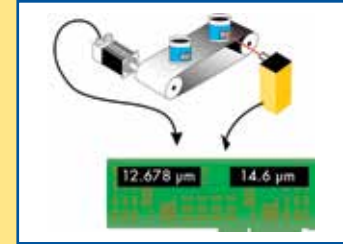

Store positions based on the transition of a digital input, allowing close correlation of axis positions to external events.

Retrace

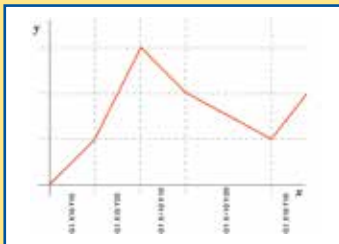

Retrace a path block by block.

Intra-Block Retrace

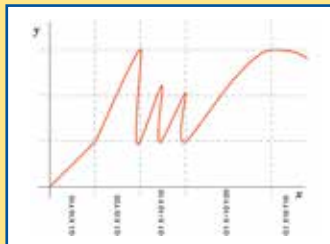

Retrace a path inside a block.

High-Speed Registration

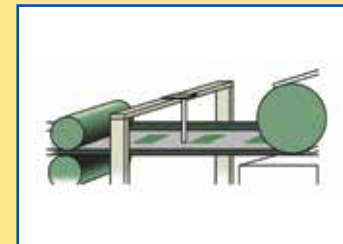

High-speed registration to trigger motion is useful in packaging and labeling.

Gantry Mode



Complex gantry control is reduced to a few simple commands to handle dual motor and/or dual feedback configurations.

Kinematics

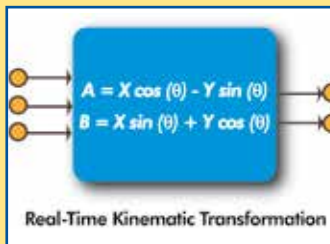

Execute complex inverse kinematic equations within the flow of the trajectory generation.

Analog Power Control



Adjust the setting of an analog output in relationship to the vector speed of two axes to permit the automatic regulation of laser power or material dispensing processes.

Standard Control Capabilities

Motor Control

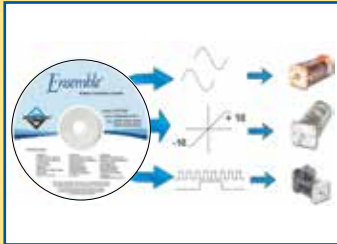

All controllers operate brush, brushless or stepper motors in any combination.

Orthogonality Correction

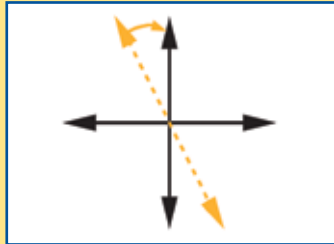

Improve X-Y planar accuracy by simply entering the known orthogonality error and the controller will compensate.

Axis Calibration

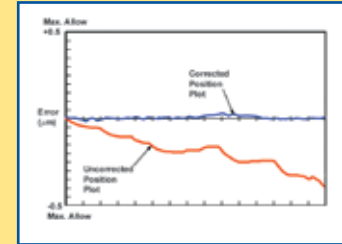

Compensate for repeatable mechanical errors in a positioning system.

Sinusoidal Commutation

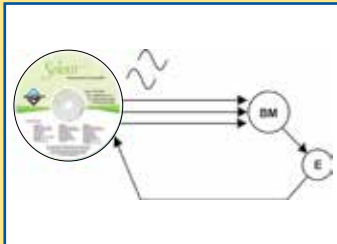

Brushless motors produce smoothest motion when sinusoidally commutated, eliminating the need for multiple transducers and reducing cabling.

3D Error Correction

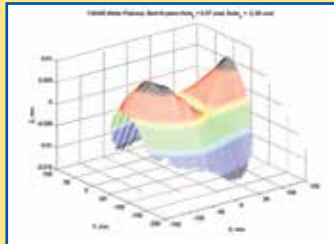

Measure XYZ errors and the controller can correct the commanded position to accurately move to all locations in the 3D space.

Dual-Loop Control

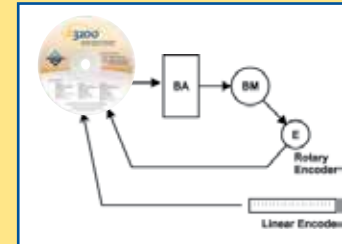

Dual-loop control is used to eliminate the effects of backlash and other sources of error.

Quadrature Encoder



Use a standard A,B quadrature encoder, incremental or absolute.

Analog Feedback



For high resolution, short travel applications, linear drives accept analog inputs from analog sensors.

Resolver/Inductosyn

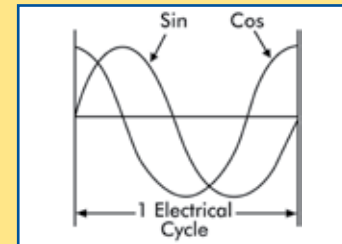

Programmable carrier frequencies make resolvers/inductosyns easy to integrate.

Laser Interferometer



Systems requiring ultra-high resolution and feedback stability use interferometer feedback.

Encoder

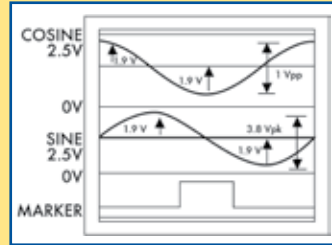

Systems requiring high resolution use a 1 Vpp encoder with Aerotech multiplier, up to 65,536 and 2 MHz input frequency.

Tachometer

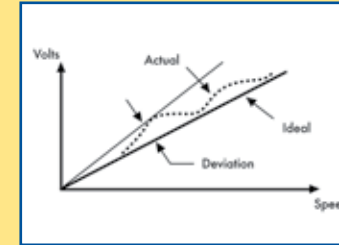

For dual feedback systems use tach for velocity control and encoder for position control.

PIDFF

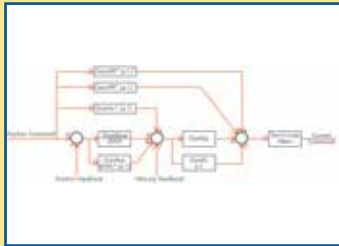

PID digital control loop with feedforward for velocity, acceleration and friction.

Safe Zones

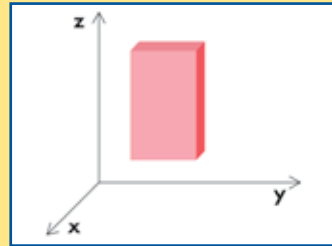

Safe zones can be set up on multi-axis systems to protect against crashes.

Slice Move

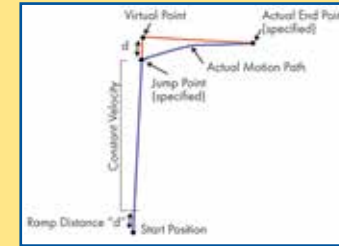

Increase scanning throughput by blending step and scan into a contoured move.

Limits



Set up hard limits and soft limits for maximum safety and flexibility.

Spindle Control



Spindle commands use standard m-codes.

CAM Profiling

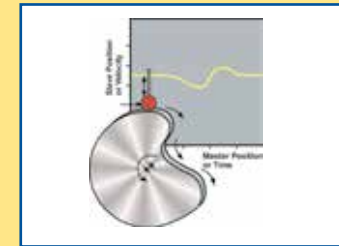

Electronically command one axis position as a function of another axis with a CAM table and fire I/O during the move.

Reduce Position Error

Harmonic Cancellation

- Reduce position error on periodic trajectories
- Reject periodic disturbances
- Built-in setup wizards
- Adapts to magnitude and frequency of error source

Continuously adapts and tracks sinusoids

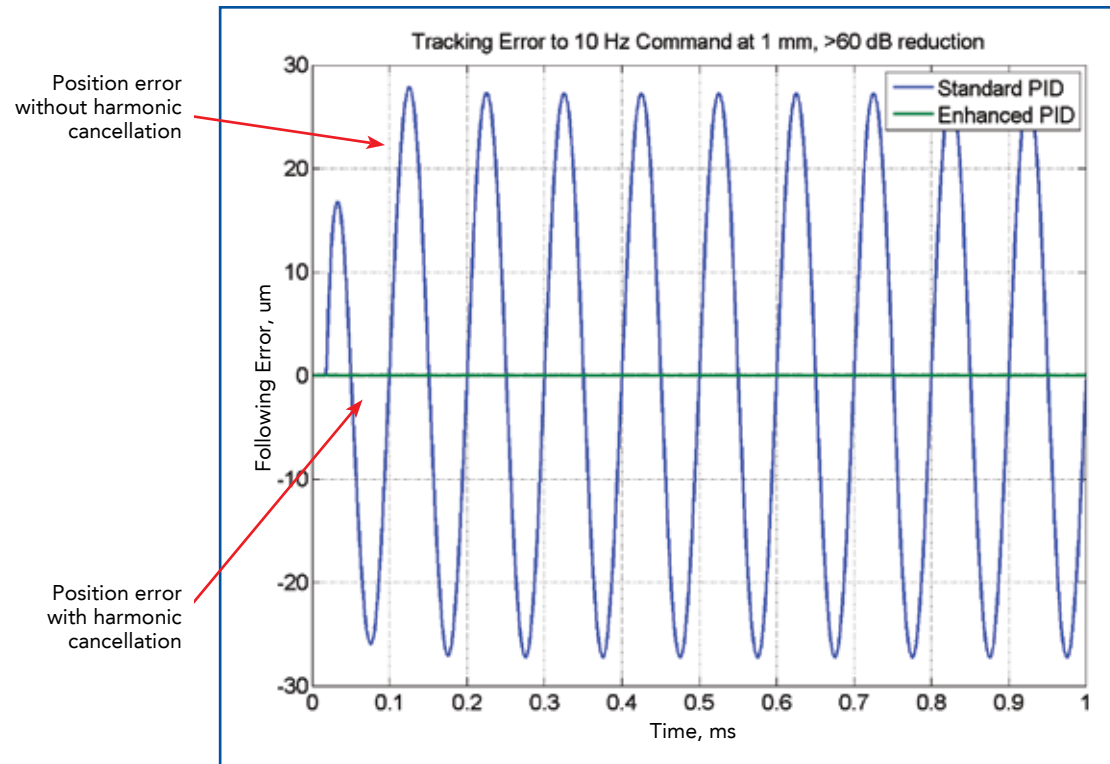

10 Hz Command; ± 1 mm

Applications

- Machining
- Spindle Control
- Cogging Reduction
- EDM/ECM
- MEMS Sensor Testing
- R0 Wafer Inspection

1st Iteration

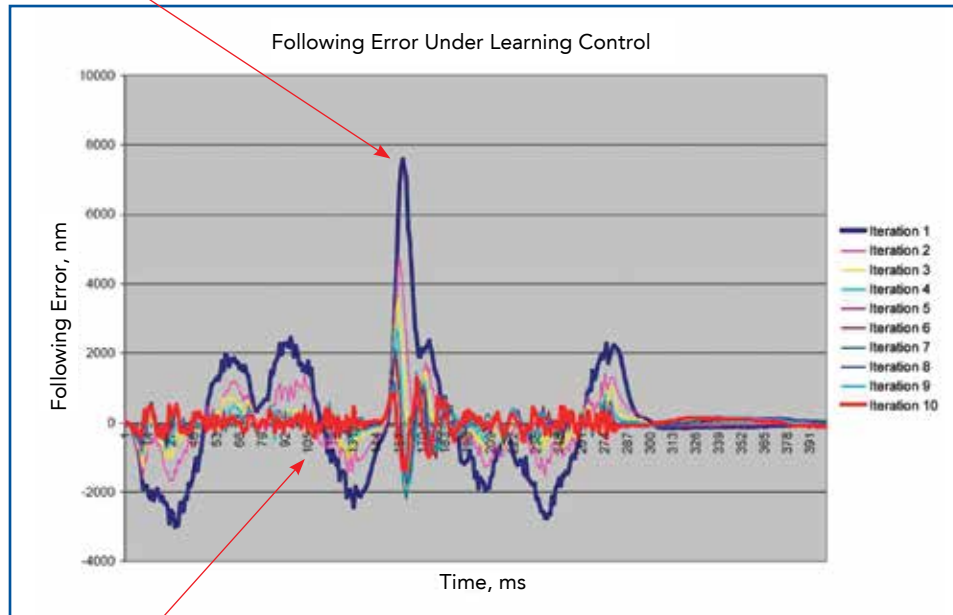

Final Iteration

Iterative Learning Control

- Repeating move sequences can be learned and optimized
- Reduce following error
- Increase dynamic accuracy
- Increase production rates

Applications

- Stencil Cutting
- Sensor Testing
- Stent Cutting
- Micromachining

Improved Settling Time

Enhanced Throughput Module (ETM)

- Multi-axis feedforward capability
- Faster settling time
- Increase rate stability

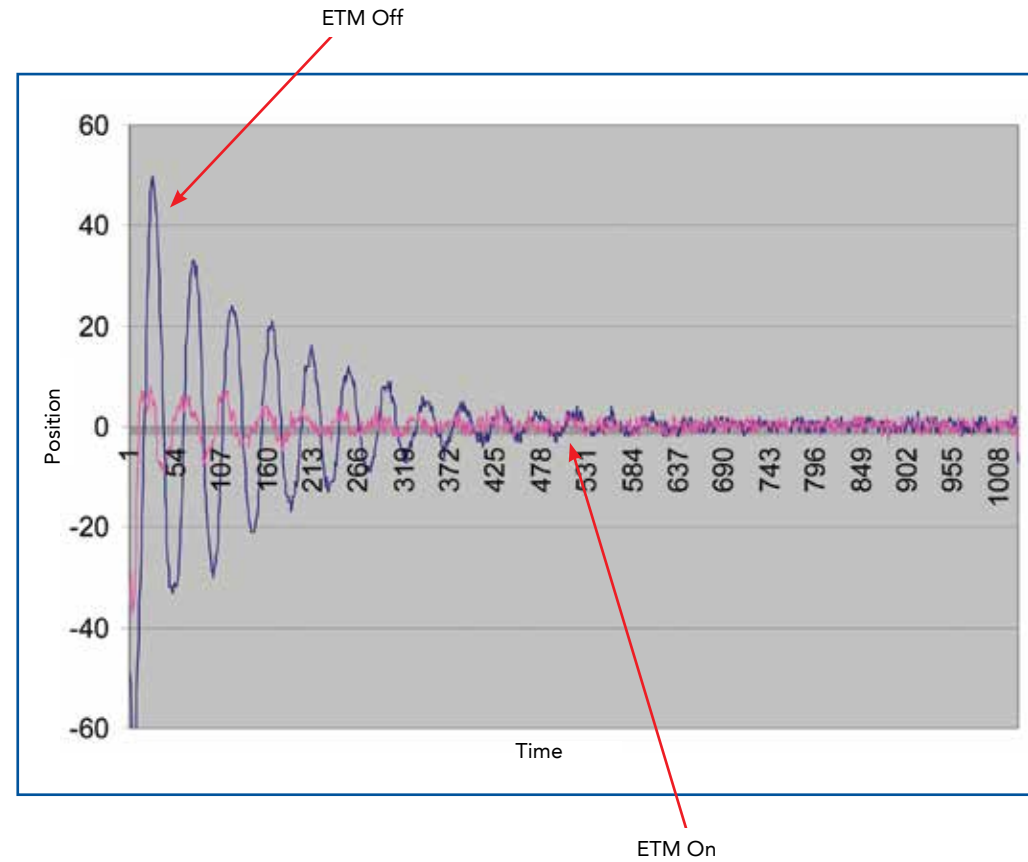

Applications

- Pick and Place Machines
- Semiconductor Inspection
- Genome Sequencing

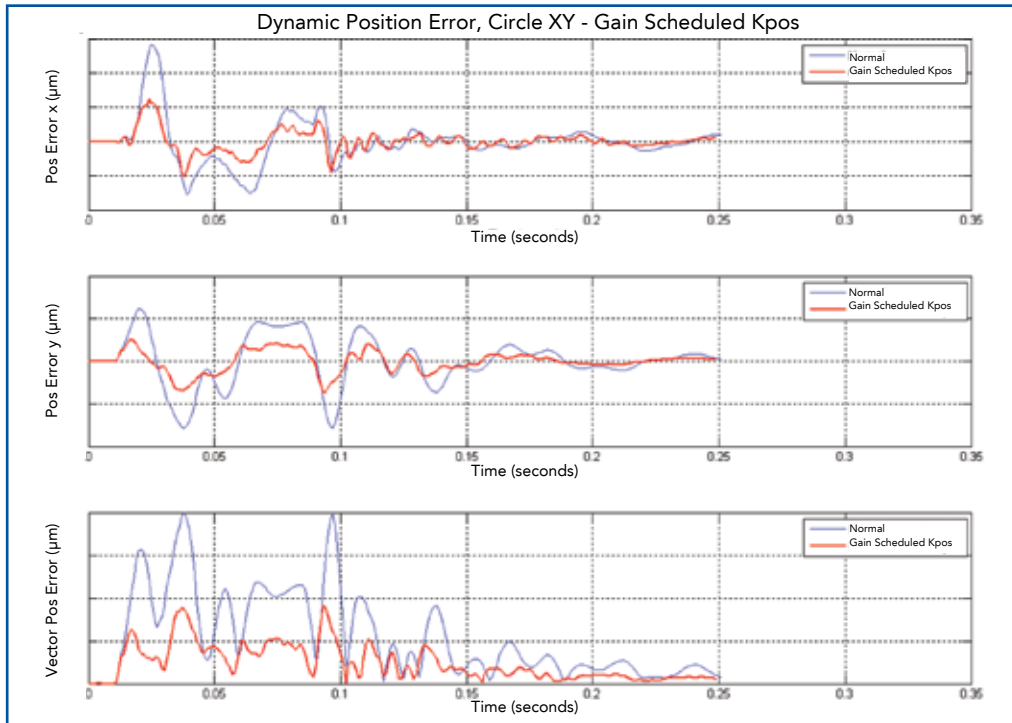

System automatically adjusts gain based on error motion during settling

Directional Gain Scheduling

- Decrease settle time
- Increase in-position stability

EasyTune®/EasySetup

- Automatically tune servo and piezo axes
- Hands-off! EasyTune requires no user input or controls knowledge
- Set a custom performance target – improves throughput and system stability

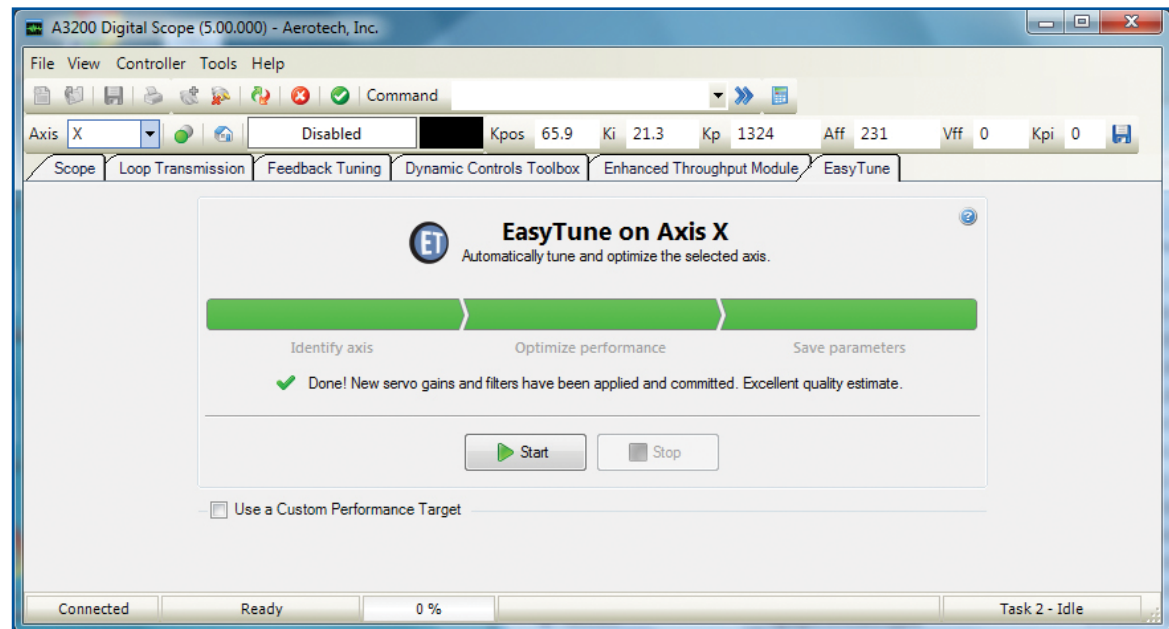

EasyTune®

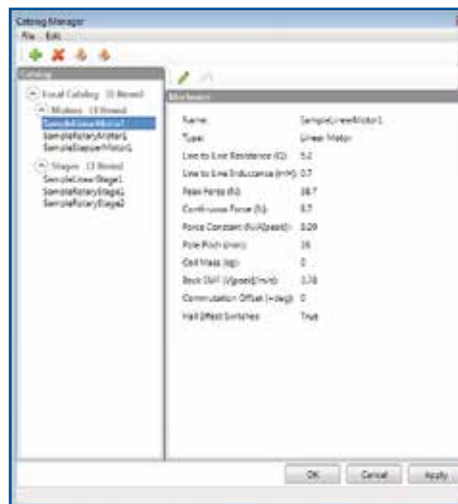

Catalog Manager

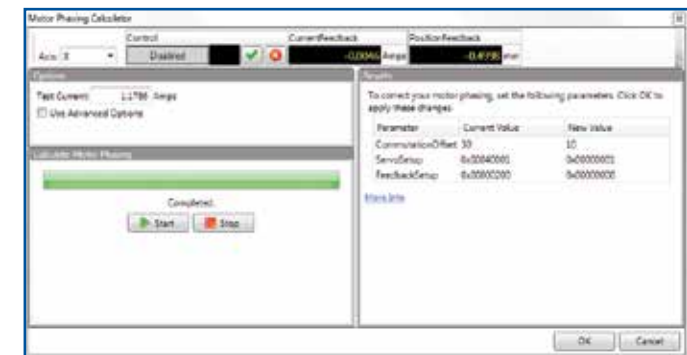

Motor Phasing Calculator

Reduce cross-axis position error during acceleration

Without cross-axis feedforward

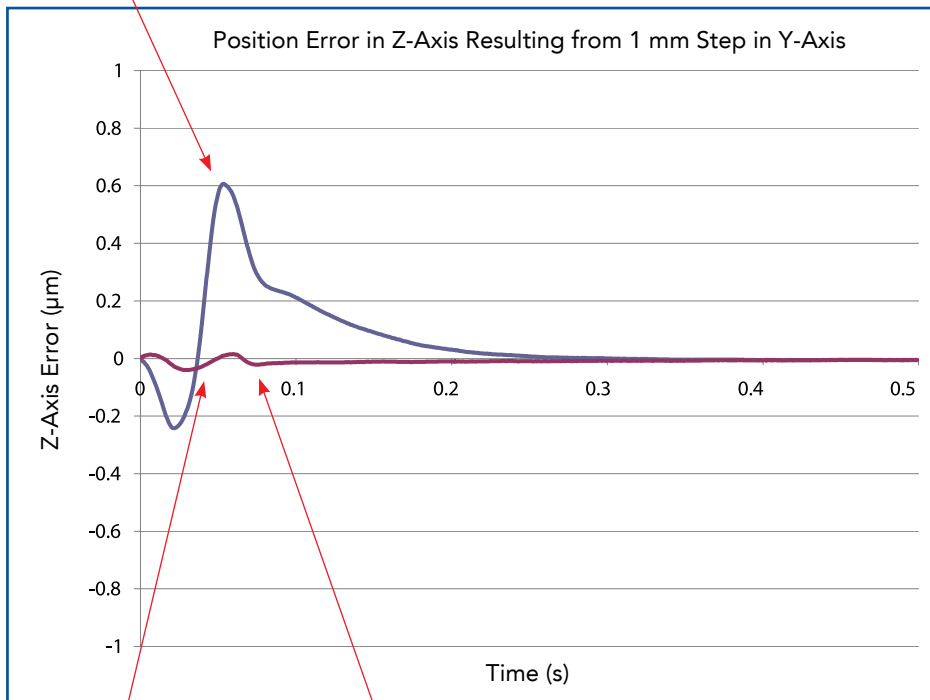

15x reduction in peak error

With cross-axis feedforward

Cross-Axis Feedforward

- Reduce position error on an axis due to acceleration of another axis

Reduce Vibration at the Work Point

Command Shaping

- Increase throughput
- Faster settle time at the work point
- No additional sensors required
- Reduced vibration in point-to-point moves
- Easy tuning

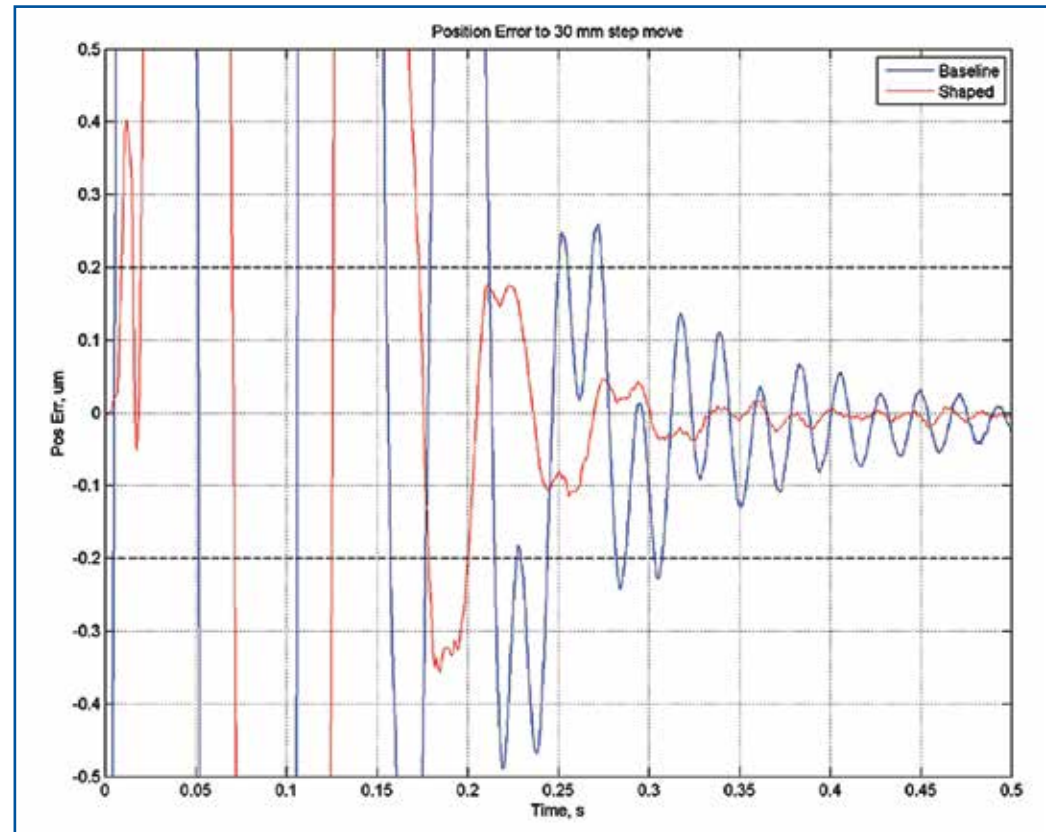

Position error at work point to 30 mm step move

Applications

- Pick and Place Machines
- Semiconductor Inspection
- Genome Sequencing

High Accuracy Firing Based on Actual Calibrated Encoder Counts

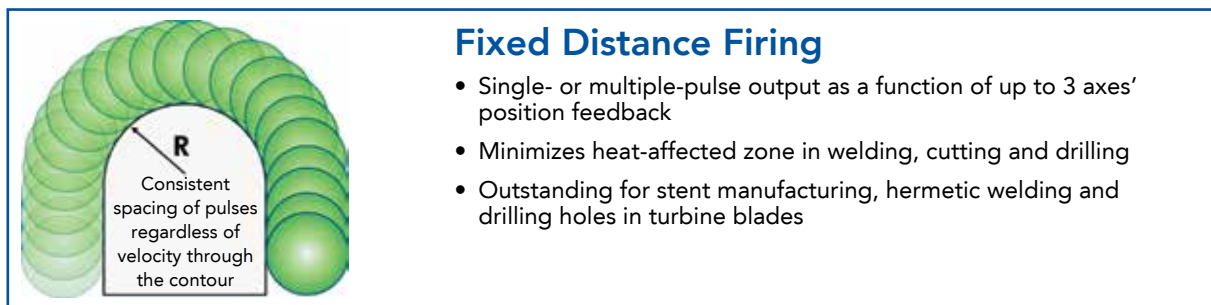
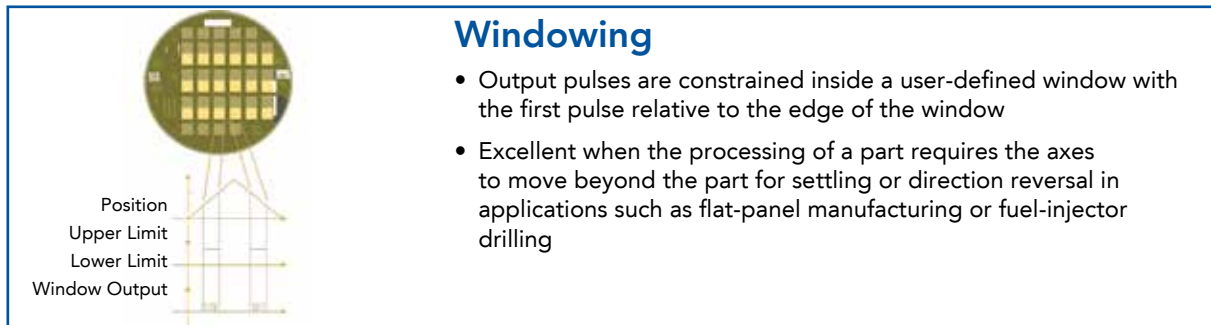
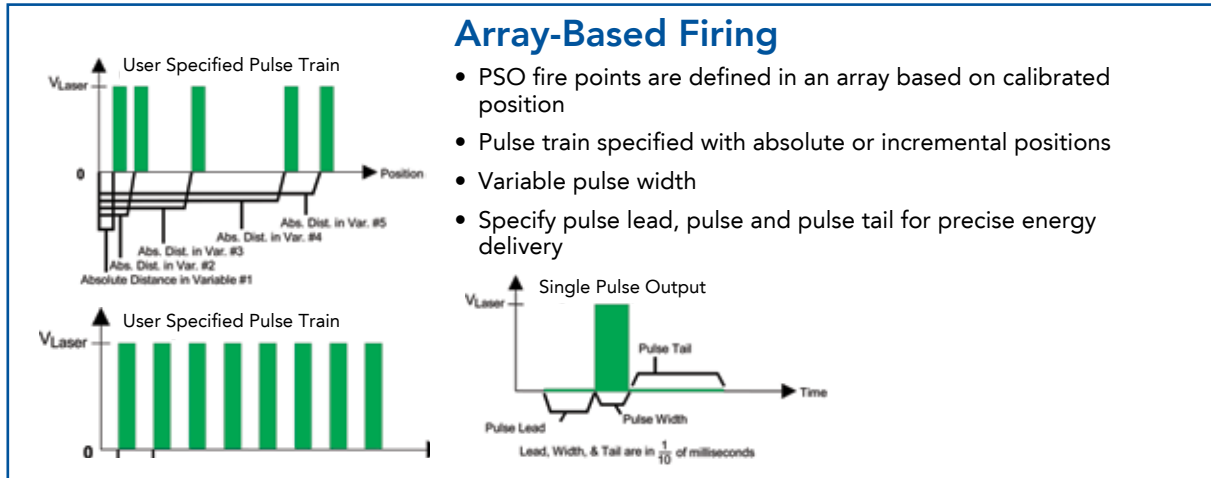

Position Synchronized Output (PSO)

- Increase throughput
- Higher accuracy
- 1-, 2- or 3-axis PSO
- Configurable command pulse train
- Use to trigger
 - Laser firing
 - Camera capture
 - Data acquisition
 - Nondestructive test triggering

Gantry Control

- Both spars are programmed and commanded as a single axis
- Easy homing
- Marker offset for high accuracy
- Orthogonality correction



Gantry Modes

- Current Synchronization
- Position Synchronization

Gantry Configuration

- 2 Motors, 2 Encoders
- 2 Motors, 1 Encoder
- 1 Motor, 1 Encoder

Open architecture, PC-based robot controller for three-axis (X/Y/Z) Delta robots. Includes a pre-configured installation of Aerotech's A3200 automation platform with robot specific programming extensions, NEMA 32 frame size motors, drives, and cables. Key system features include:



Delta Robot Control

- Industrial panel-mount PC with solid-state disk drive
- Teach mode with user defined number of points
- Synchronization with moving material
- Target position command queue of user defined depth
- Real-time simultaneous display of tool and work-point coordinates
- G code and AeroBasic™ motion command syntax
- Control up to 20 additional axes
- Optional IEC 61131-3 PLC interface with support for PLCopen and .NET
- Servomotor with absolute feedback device and brake
- Ndrive CP10 drives
- 5 meter long motor power and feedback cables

Directly Synchronize Scanhead and Servo Motion for Ultimate Flexibility in Marking Applications

Laser Marking– Nmark® CLS

(Closed-Loop Scanner)

- Expand scanner field-of-view without sacrificing effective pixel resolution
- Mark long vectors with one continuous pass
- Draw large-scale graphics without stitching multiple exposures
- Mark on a tube or other irregularly shaped object without manually repositioning
- Single programming environment for both scanner and servo axes minimizes application complexity
- Eliminate angular errors
- Scanner programmed with standard RS-274 G code
- Laser firing based on real-time scanner position

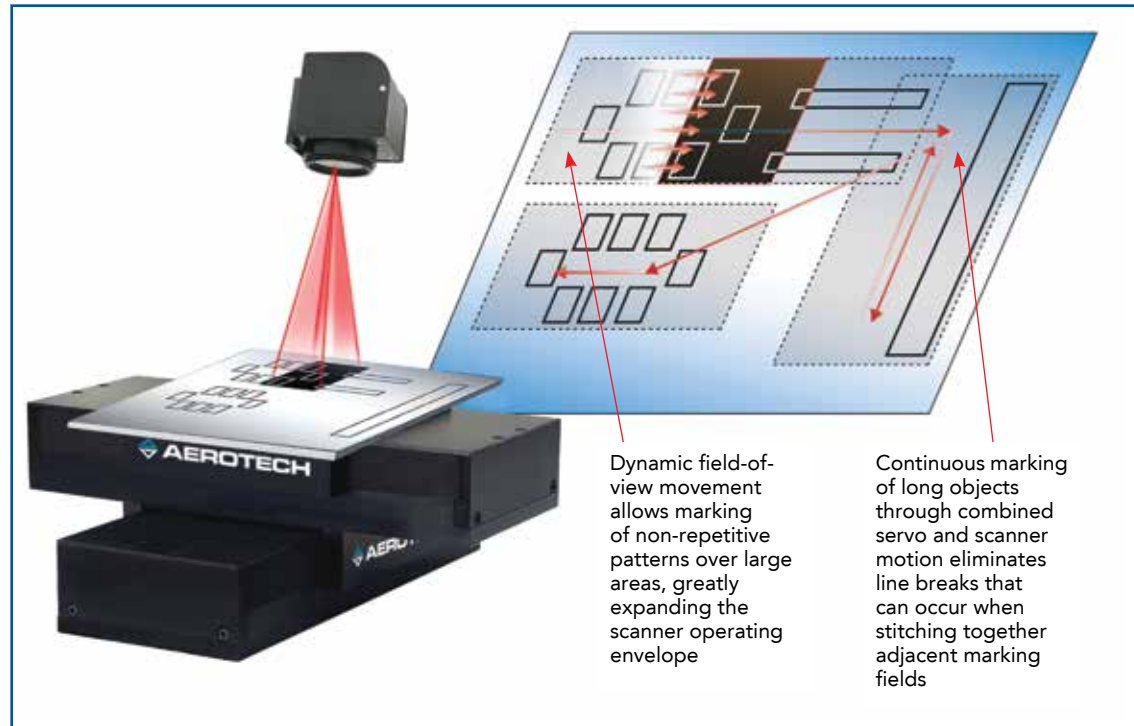



Nmark AGV-HP

- Highest accuracy scanner available attains single-digit, micron-level accuracy over the field of view
- Optical feedback technology significantly improves thermal stability
- Industry-best resolution of >24 bits when used with Aerotech's Nmark GCL controller
- Wide range of apertures and focal lengths



Nmark AGV-HPO

- Highest accuracy scanner available attains single-digit, micron-level accuracy over the field of view
- Optical feedback technology significantly improves thermal stability
- Industry-best resolution of >24 bits when used with Aerotech's Nmark GCL controller
- Wide range of apertures and focal lengths, and many choices of mirror surface treatments for a variety of laser wavelengths



Nmark GCL

- Closed-loop, two-axis servo drive for Aerotech's AGV series scanners
- Infinite Field of View (IFOV) seamlessly combines AGV and servo motion to expand the scanner work area
- Full servo state control with "zero-tracking error" eliminates speed-related part distortion such as necking on circles and rounding of corners
- Position-based laser firing (PSO) with windowing maintains consistent spot spacing over a wide range of operating speeds

High-Performance Galvanometer Scanners

Vector Applications

- Cutting
- Welding
- Sealing
- Ablation
- Marking

Graphic Applications

- Bar Code
- Serialization
- Engraving
- Character Scribing

Friction Compensation

- Reduced settle time
- Reduced error at direction reversals

Advanced Friction Model

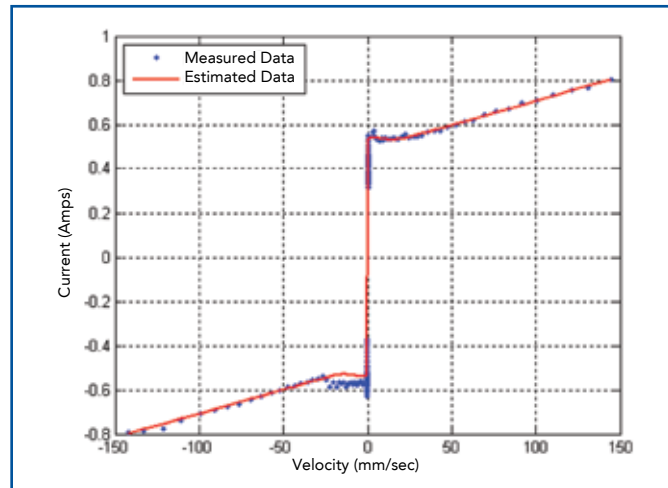

High speed, high accelerations and minimal position error achieved with feedforward additive force

Friction Compensation Results

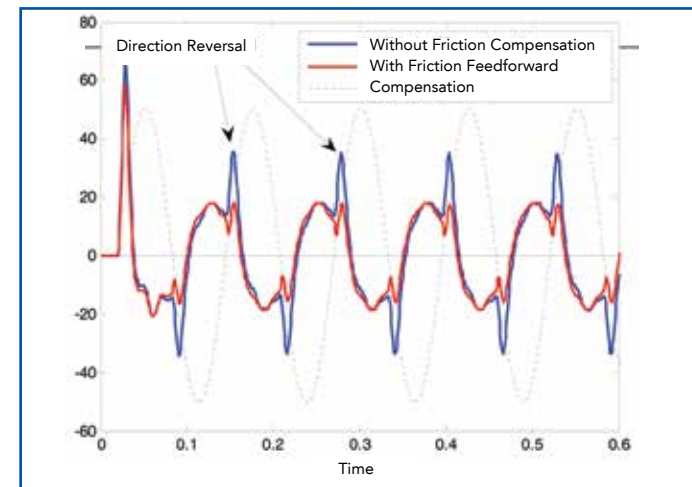

Fieldbus and Networking

Aerotech controllers support a multitude of industry-standard communication protocols to facilitate easy component networking, device connectivity and superior motion system performance.

Networking Type	Plant					Fieldbus						Motion		Drive I/O	
	Ethernet TCP/IP	USB	RS-232	RS-485	OPC*	EtherCAT	EtherNet/IP™	DeviceNet™*	CANopen*	PROFIBUS	Modbus® TCP	FireWire®	Aeronet	Analog	Digital
A3200	✓				✓	✓		✓	✓	✓		✓		✓	✓
Ensemble	✓	✓	✓	✓	✓		✓	✓	✓	✓	✓		✓	✓	✓
Soloist	✓	✓	✓	✓			✓	✓	✓	✓	✓			✓	✓
Summary	Aerotech controllers connect seamlessly to your existing corporate network or PC via these standard protocols.					Aerotech controllers support a variety of fieldbus communication protocols to fit your application.						Aerotech controllers use state-of-the-art communication standards for motion network communication to ensure a robust, high-performance system.		Aerotech drives include a standard complement of on-board analog and digital I/O, with an option for an expanded I/O board.	

*Coming Soon



Fieldbus I/O with Hilscher NetX technology

Corporate networking protocols allow remote control and monitoring of your motion system.

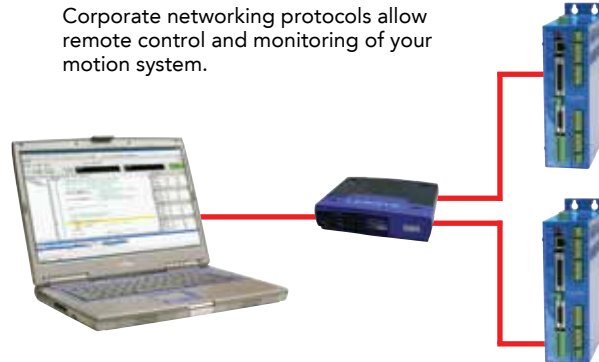

Fieldbus communication protocols provide extensive options for communicating with PLCs and other components in your system.

Aerotech's motion networking architectures are truly plug-and-play, making setup quick and easy.

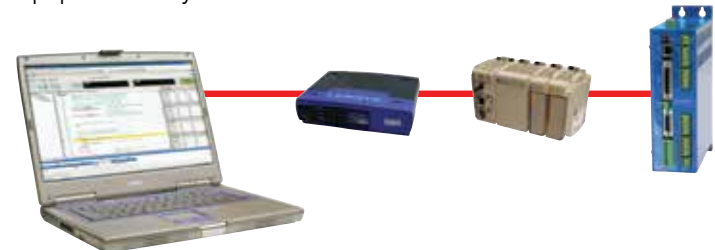

Aerotech's HEX RC

Aerotech's HEX RC is a high-performance, 6-axis motion controller ideal for controlling robotic systems like hexapods. The HEX RC is 4U high, rack-mountable, and compatible with the Automation 3200 (A3200) motion platform. A high-performance processor provides the intense computing power needed to run up to 32 axes, perform complex, synchronized motion trajectories, manipulate I/O, and collect data at high speeds.

- 4U high, rack-mount, six-axis controller for brush, brushless, and stepper motors
- Ideal for controlling six-axis robotic systems like hexapods
- Real-time A3200 distributed control architecture allows synchronized motion on up to 32 axes
- FireWire® or ASCII command interface via TCP/IP
- Optional integrated encoder multipliers for high resolution positioning and reduced integration complexity
- Optional six-axis jog pendant
- Program in native RS-274 G-code, AeroBasic™ command set, C, C++/CLI, .NET, MATLAB®, LabVIEW®, or IEC 61131-3 (LD, FBD, ST) for the ultimate in programming flexibility





Ensemble QL/QLe™

The Ensemble QL/QLe™ panel-mount nanopositioning piezo drive family is designed for seamless use with the Ensemble family of drives and controllers. The QL/QLe connects to any Ensemble controller network enabling coordinated motion between piezo stages and servo axes at much higher rates than other controller or drive products. This power, versatility, and affordability make the Ensemble QL/QLe drives ideal for applications ranging from the most demanding fundamental scientific research to advanced OEM machine systems.

Ensemble QDe™

The Ensemble QDe™ is a high-performance desktop nanopositioning piezo drive designed for seamless use with the Ensemble family of drives and controllers. The QDe connects to any Ensemble controller network enabling coordinated motion between piezo stages and servo axes at much higher rates than other controller or drive products. This power and versatility make the Ensemble QDe ideal for single or multi-axis applications ranging from fundamental scientific research to advanced OEM machine systems.

Ensemble QLAB™

The Ensemble QLAB™ is a high-performance nanopositioning piezo stage controller for 1 to 4 axes of motion. The flexible controller platform allows user-configurable open-loop and closed-loop operation on a per axis basis. Simple software commands allow the user to switch between open-loop and closed-loop if an axis is configured for closed-loop mode.

Controller Comparison Chart

Unsure about which controller is right for your application?

Consult the chart to see which controller fits your needs.

Basic Functions	A3200	Ensemble	Soloist
Multi-Axis	Up to 32 axes coordinated	Up to 10 axes coordinated	Single axis
Architecture	PC-based software controller	Stand-alone	Stand-alone
Number of Tasks	32	4	4
CNC Functionality/RS-274	✓		
Coordinated Motion	✓	✓	
Point-to-Point Motion	✓	✓	✓
Cutter Compensation	✓		
Multi-Block Look-Ahead	✓		
Acceleration Limiting/Look-Ahead	✓		
Gantry Mode	✓	✓	
Velocity Blending	✓	✓	✓
Electronic Gearing	✓	✓	✓
Electronic Cam Profiling	✓	✓	✓
Arbitrary Path Generation	✓	✓	✓
Jog and Offset, Jog and Return	✓		
Velocity Profiling	✓	✓	✓
Retrace (Block by Block)	✓		
Axis Calibration	✓	✓	✓
3D Error Mapping	✓		
Sinusoidal Commutation	✓	✓	✓
Analog Power Control	✓	✓	✓
Servo, Stepper or DC Motor Controller	✓	✓	✓
Expanded IO Available	✓	✓	✓
Encoder Tuning	✓	✓	✓
Dual Loop Control	✓	✓	✓
PLC (IEC 61131-3)	✓		

Advanced Functions	A3200	Ensemble	Soloist
IDE	✓	✓	✓
.NET, AeroBasic™	✓	✓	✓
Fast Position Capture	✓	✓	✓
High-Speed Registration	✓	✓	✓
On the Fly End-Point Modification	✓	✓	✓
Orthogonality Correction	✓	✓	✓
Parts Rotation	✓		
Intra-Block Retrace	✓		
Iterative Learning Control	✓	✓	✓
PSO	Yes, up to 3 axes	Yes, up to 3 axes	Yes
Harmonic Cancellation	✓	✓	✓
Direction Gain Scheduling	✓	✓	✓
Inertial Damping	✓	✓	✓
Friction Compensation	✓		
Linear Drive Amplifiers	✓	✓	✓
Machine Retrofit Hardware Available	✓		
Galvo Integration	✓		
Seven Segment Acceleration Profile	✓	✓	✓
Slice Move	✓		
Corner Rounding	✓		
Coordinate Transformations	✓	With Plug-In	
Kinematics	✓	With Plug-In	
Loop Transmission	✓	✓	✓
Advanced Diagnostics and Tuning	✓	✓	✓
Auto Focus	✓	✓	✓
MATLAB®	✓		
Force Control	✓	✓	✓
Soft Landing	✓	✓	✓
Piezo Nanopositioners	✓	✓	
HexGen Hexapod	✓		
RCP-DELTA Delta Robot	✓		

**Use the Best
Controller
for Your
Application**

- Wired and tested consoles
- Wired panels and 19-inch racks
- Integrated subsystem with PC, controls, drives, cables, power supply or transformer, line filtering, PLC motion, I/O and customer I/O
- CE/UL standards
- Comply with NFPA79 wiring standard

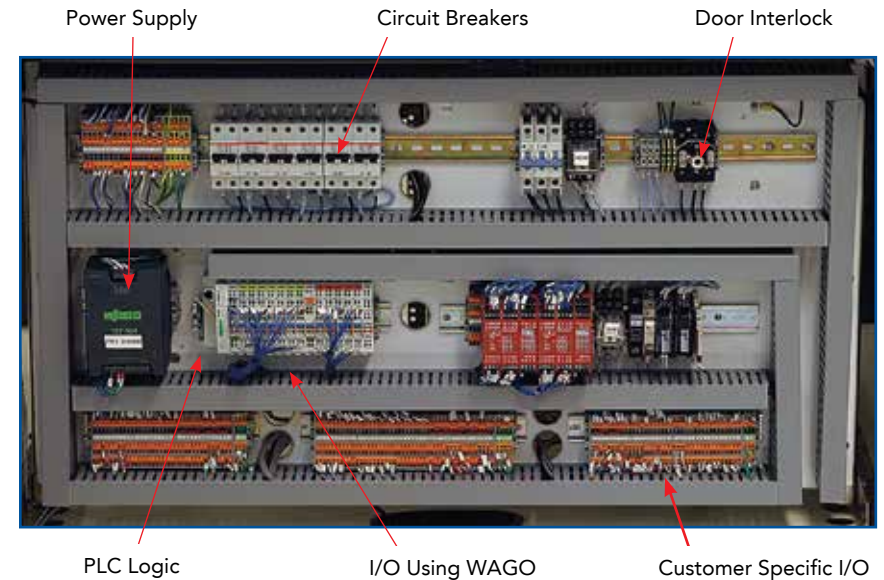

Nsys Complete Consoles

Complete consoles are available that integrate all of the electronics for your system, including the controller, drives and/or drive racks, I/O and monitor.



Aerotech Machine Safety Standards



Safety Level	Fault Detection	Loss of Safety Function Probability	Single Fault Covered	Double Fault Covered	Input ESTOP Signal	Supply Power to Drive
Category B	None	Very High	No	No	No specific design	No specific design
Category 1	None	Very High	No	No	Simple mushroom switch	One relay
Category 2	Low	High	No	No	Simple mushroom switch	One positive guided relay with auxiliary contact for checking
Category 3	Medium	Medium	Yes	No	Dual circuit mushroom with fault detection	Two positive guided relays with cross checking
Category 4	High	Low	Yes	Yes	Dual circuit mushroom with independent fault detection	Two positive guided relays with cross checking

Hardware Options

	MP	CP	HPe	HLe	ML	Integrated Drive Racks		Nservo	Nstep	Nmark™	Console	QL/QLe	
A3200 Drives													
Ensemble Controls								N/A	N/A	N/A	N/A		
Soloist Controls						N/A		N/A	N/A	N/A	N/A	N/A	
Axes	1	1	1	1	1	1 to 8	1 to 8	2 or 4	2 or 4	3	1 to 12		
Output Type	PWM	PWM	PWM	Linear	Linear	PWM and Linear	PWM and Linear	Three-Phase ±10 V	Clock and Direction	Clock and Direction	N/A		
Peak Output Current	10 A	10-30 A	10-150 A	10-20 A	10 A	Npaq: 10-30 A Npaq MR: 10 A Hex RC: 10 A	Epaq/Epaq MR: 10 A Epaq: 10 A Ensemble LAB: 5 A Ensemble QLAB: 300 mA Ensemble QDe: 250 mA	N/A	N/A	N/A	N/A		
DC Bus Voltage	10-80 VDC (Output)	10-320 VDC	10-320 VDC	±40-80 VDC	±40 VDC	Npaq: 10-320 VDC Npaq MR: 10-80 VDC Hex RC: 80 VDC	Epaq: 24-90 VDC; ±10-40 VDC Epaq MR: 10-80 VDC Ensemble LAB: ±24 VDC Ensemble QLAB: -30 to +150 V Ensemble QDe: -30 to +150 V	N/A	N/A	N/A	N/A		
Standard I/O	1-AI	6-DI/4-DO 1-AI/1-AO	6-DI/4-DO 1-AI/1-AO	6-DI/4-DO 1-AI/1-AO	6-DI/4-DO 1-AI/1-AO	Multiple Configurations Available	1-AI per axis	11-DI/8-DO 4-AI/2-AO	16 Assignable IO	N/A	N/A		
Optional I/O	8-DI/8-DO 1-AI/1-AO	16-DI/16-DO 1-AI/1-AO	16-DI/16-DO 4-AI/4-AO	16-DI/16-DO 4-AI/4-AO	16-DI/16-DO 1-AI/1-AO	Multiple Configurations Available	Multiple Configurations Available	Via Optional Ethernet Port	N/A	N/A	N/A		
I/O Spec	12-bit differential AI 16-bit single-ended AO	16-bit differential AI 16-bit single-ended AO				Npaq or HEX RC: Four 16-bit differential AI Two 16-bit single-ended AO Npaq MR: Same as ML or MP per axis		Epaq or Epaq MR: Same as ML or MP per axis Ensemble QLAB: 4 AI, 4 AO Ensemble QDe: 1 16-bit, 1 18-bit	Two 16-bit differential AI Two 16-bit single-ended AO	N/A	N/A	N/A	
Incremental Encoder	✓	✓	✓	✓	✓	✓	✓	✓			✓		
Absolute Encoder		✓	✓	✓			✓	✓			✓		
Resolver/ Inductosyn			✓	✓		✓		✓			✓		
Capacitive Probes					✓	✓							
Laser Interferometer						✓							

All units capable of sinusoidal commutation, dual-loop control and drive brushless, brush, or stepper motor

The BA series amplifiers are Aerotech's stand-alone PWM drive for three-phase AC brushless and single-phase DC brush motors.

BL series amplifiers are highly reliable linear brushless servo amplifiers.



BA PWM Amplifiers

- Wide output power range from 10 A peak to 100 A peak at 320 VDC
- No transformer required; direct connection to AC line
- Capable of running brushless or single-phase DC brush motors
- Velocity, torque and dual-phase mode input command
- Accepts both encoder or tachometer feedback for velocity control
- Can be externally commutated
- UL, CE and CSA approval



BL Linear Amplifier

- Non-switching, high-performance linear operation for ultra-smooth control of brushless motors
- Totally modular design accepts 110 VAC or 220 VAC input power
- Ideal for air-bearing systems and noise-sensitive applications

Rotary Motors

- Ironless/cogless design for superior motion
- Iron-core motors for high force output
- Frameless torque motors for custom machines
- Ultra-precision positioning
- Low heat generation
- Vacuum compatible options
- NEMA 17, 23, 34, 42 and IEC 142

Torque	
Type:	Brushless
Continuous Torque:	0.16 - 31.6 N·m
Peak Torque:	0.48 - 94.9 N·m
Rated Speed:	2400 - 4000 rpm

Torque	
Type:	Brushless, Slotless
Continuous Torque:	0.27 - 2.86 N·m
Peak Torque:	1.07 - 11.43 N·m
Rated Speed:	2000 - 4000 rpm

Torque	
Type:	DC Brush
Continuous Torque:	0.25 - 1.48 N·m
Peak Torque:	1.84 - 7.1 N·m
Rated Speed:	3000 - 6000 rpm

Torque	
Type:	Stepper
Continuous Torque:	0.78 - 11.5 N·m
Peak Torque:	---
Rated Speed:	---

Full line of DC brush, brushless, servo and stepper motors to fit almost any situation. Brushless motors feature neodymium iron boron magnets for maximum torque and acceleration in a small package.



Frameless Rotary Motors

Torque

Type: Frameless
Continuous Torque: 0.20 - 29.09 N·m
Peak Torque: 0.82 - 116.37 N·m
Rated Speed: 200 - 8000 rpm

Five frameless designs for easy integration into OEM machines.

Slotless stator and high-pole-count rotor provide zero cogging for exceptional velocity control.



Brushless Linear Servomotors — Flat and U-Channel

Force

Type: Flat
Continuous Force: 19 - 697 N
Peak Force: 75 - 1507 N

Aerotech's proprietary coil winding technology produces the highest force to volume ratios available.

Direct drive, noncontactingforcer coil eliminates backlash, windup and wear for a maintenance-free system.

Force

Type: U Channel
Continuous Force: 14 - 1063 N
Peak Force: 56 - 4252 N

Linear servomotors are ideal for:

- Robotics
- Packaging
- Actuators
- Tables/Stages
- Assembly
- Fiber Optics/Photonics Alignment and Positioning
- Machine Tools
- Semiconductor Equipment
- Electronic Manufacturing

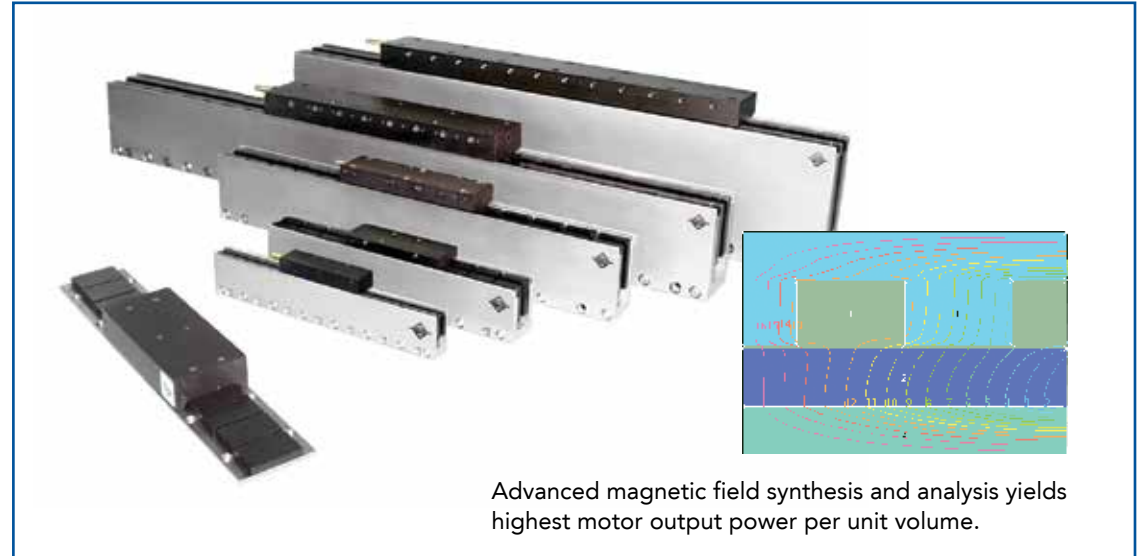

Advanced magnetic field synthesis and analysis yields highest motor output power per unit volume.

Custom Motors

We customize for you

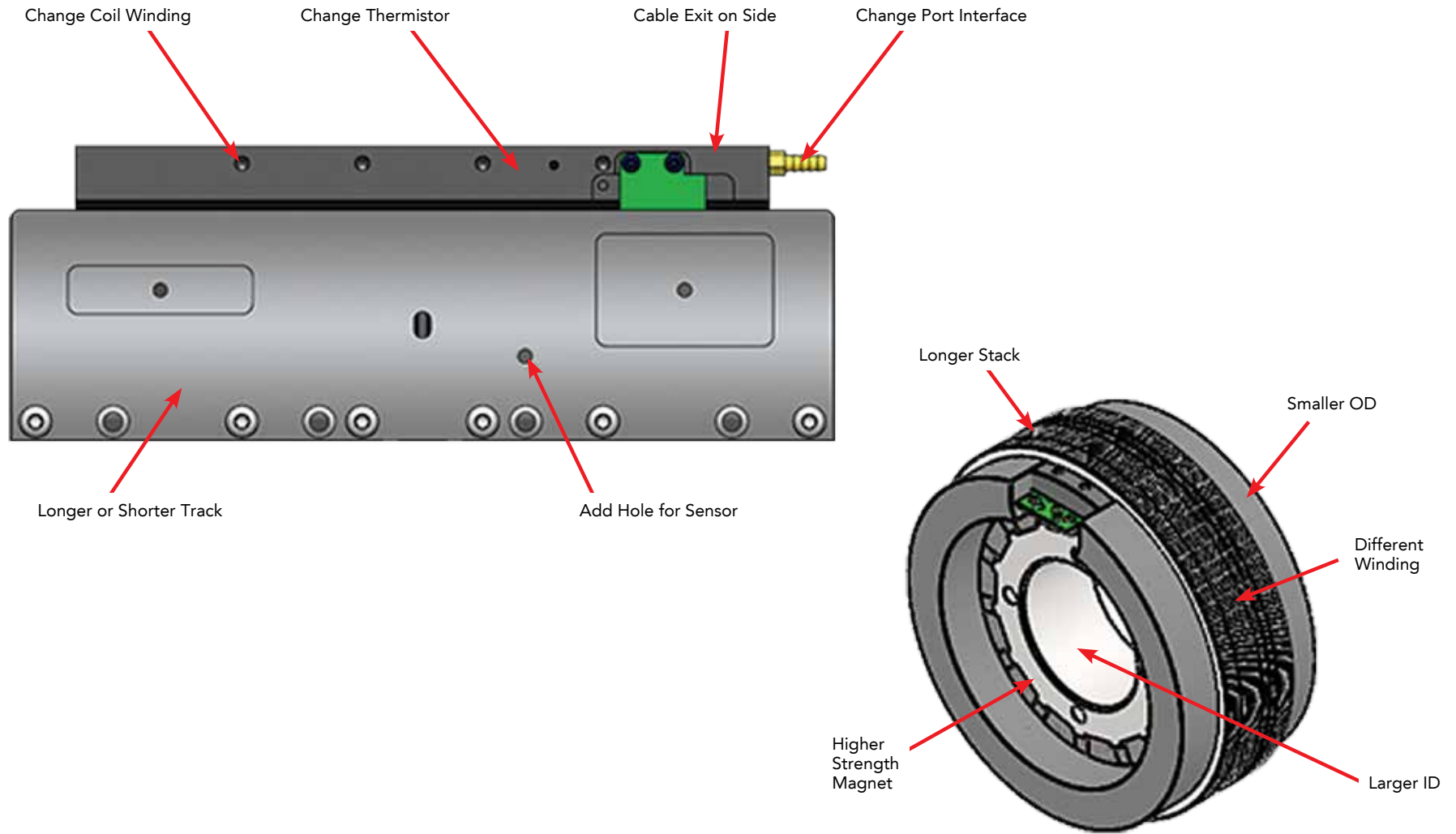

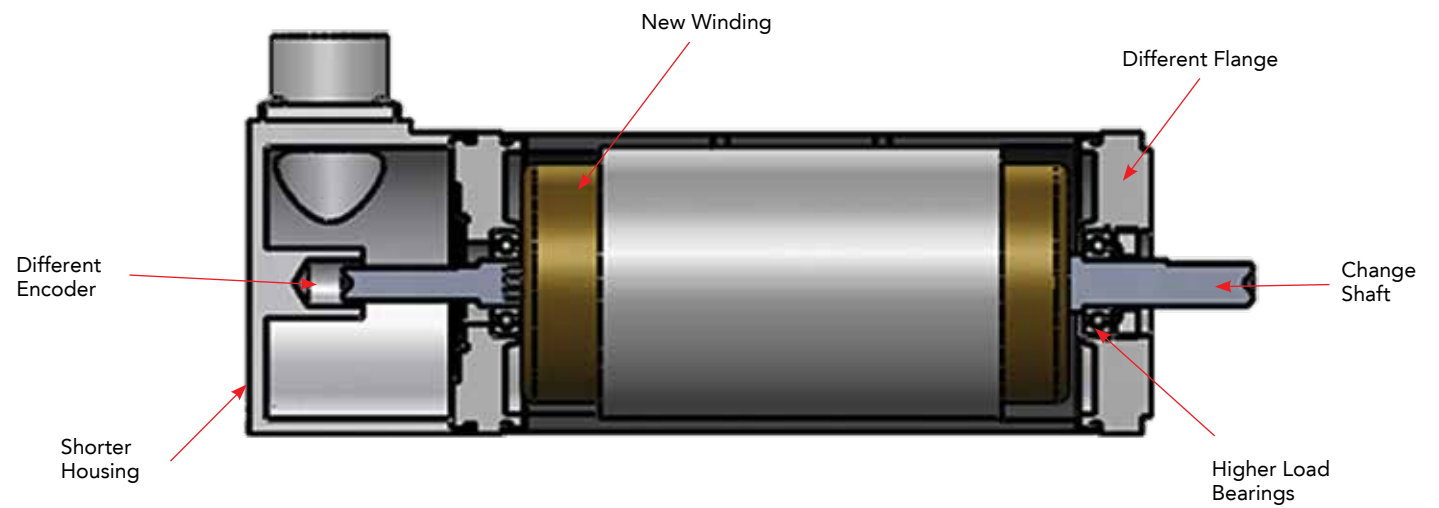
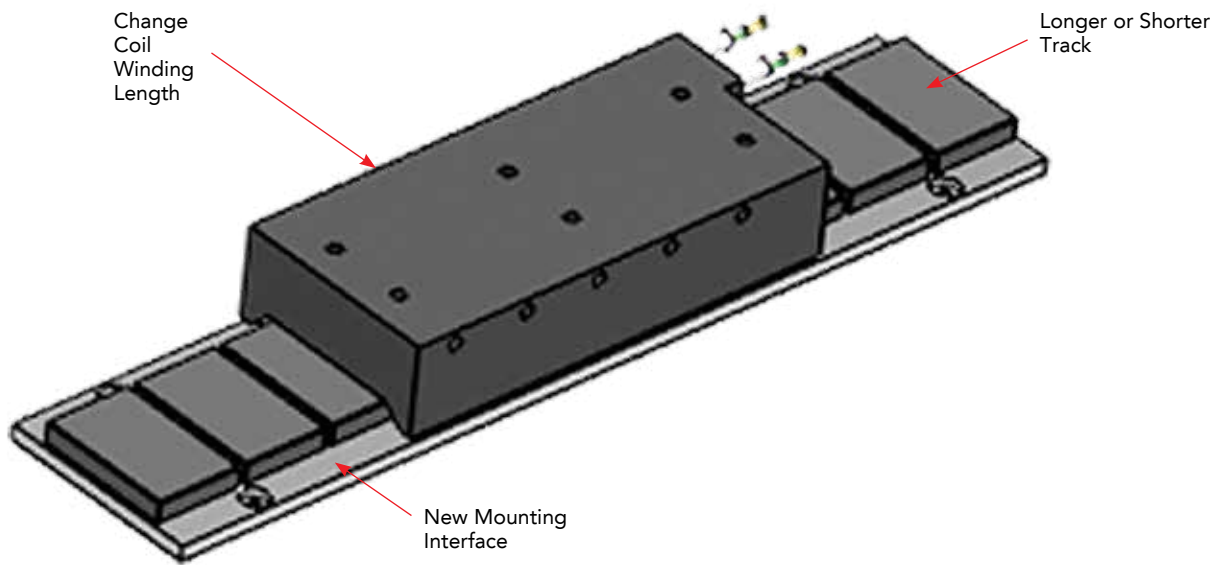

We customize for you...

Hardware • Software • Firmware • Packaging • Motors • HMI • Electronics • I/O

Connectivity

- Ethernet
- Fieldbus
- Wireless
- USB



$$\frac{T(s)}{D(s)} = \frac{s^2 \prod (s^2 + \omega_i^2)}{s^2 \prod (s^2 + \omega_i^2) + [\sum x_n \frac{(b_n s + k_n)}{(s^2 + \omega_n^2)}] \prod (s^2 + \omega_i^2)} \delta_n(s)$$

Custom Control Algorithms

- Create algorithms at the application, motion engine, firmware, or hardware layer
- Flexible control architecture
- Custom kinematics

Custom Automation

- Coordinate motion, PLC, robotics, vision, and communications with one automation control
- Galvo control
- Piezo control
- Integration with process control
- HMI integration

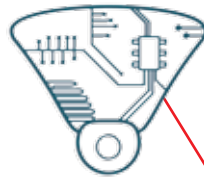

Custom Drives

- Plug-in architecture speeds development of custom algorithms – for example, 2D bar code, interfaces to non-standard sensors, and signal outputs synchronized to servo sample time
- Packaging can be customized for specific form factor and space constraints
- Custom algorithms can be developed at the firmware layer



Custom Software

- Custom operator interfaces
- Custom applications
- Custom software libraries
- Program in nearly any language



Vision Integration

- Interface with standard cameras and machine vision systems
- Registration marks or fiducials can be located and used as a home or reference position
- Vision can be coordinated with servo motion for vision guided robotics



Custom Motor Design

- Custom motors optimized for your specific application at a minimal price
- Customized motor mechanical characteristics including torque/force, length, width, height
- Customized motor electrical characteristics including bus voltage, resistance, inductance, pole pitch, and current
- Custom motors for low-volume projects
- Completely new motor design



We implement with you...

Tuning • Parameters • Optimize Performance • HMI • Write Software

We will work with you onsite or at our facility to meet your machine specifications.



Aerotech personnel will:

- Perform parameter setup and system tuning
- Setup of the Advanced Controls Toolbox to achieve the highest performance possible
- Write motion programs in AeroBasic™
- Write software (.NET, C) by applying our libraries
- Write PLC programs using Ladder, Function Block, or Structured Text
- Product customization
- Product application
- Write/configure HMIs
- Integration with process controller

Benefits include:

- Maximize machine performance
- Minimize machine development time
- Minimize cost



Accessories

Available Accessories:

Maple
Operator
Interface

Joystick
Handwheel/
Pendant

Transformers
Power Supplies

Cables
Automation

Server
MXH Multiplier
Boxes

Line Filters
Panel PC



Markets and Industries



Laser Processing
Semiconductor Processing
Military and Aerospace
Electronics Manufacturing
Medical Device Manufacturing
Test and Inspection

Machine Tools
Automotive
Packaging
University Research
Industrial R&D
Photovoltaic Manufacturing



Aerotech controls and components have become the preferred solution for a variety of applications in a host of industries around the world.

Aerotech Customer Applications

- Labeling
- Web Applications
- Case Erectors

A3200

- Stencil Cutting
- Wire Bonding
- Die Bonding
- Optics Polishing
- Stent Manufacturing
- e-Beam Welding
- EDM
- Drilling and Milling
- Grinding and Polishing
- Waterjet Cutting
- Fuel Injector Drilling
- Fuel Cell Manufacturing
- Crystallography
- Target Tracking
- Beam Steering
- Pipe Thread Measurement

A3200 or Ensemble

- Dispensing (Printed Electronics, Material Dispensing)
- PCB Assembly (Pick and Place of SMT, Through-Hole)
- VIA Drilling
- Wafer Scribing and Singulation (Dicing)
- Die Bonding
- Resistor Trimming
- AOI/X-Ray Inspection
- Chip Testing
- Chip Packaging
- Crystallography
- Flat Panel
- Semiconductor Testing
- Semiconductor Manufacturing
- Photovoltaic Cell Manufacturing
- DNA Analysis
- Image Duplication
- Holographic Writing
- Sensor Testing
- Sensor Manufacturing

Ensemble

- Packaging Machines (Multi-Axis Applications)
- Web Applications
- Printing Applications
- Rollover Unit Testing
- IMU Testing
- ECM
- Marking
- Vertical Form, Fill, and Seal

Soloist

- EDM & ECM
- Packaging Machines (Case Erectors, Labeling Machines, Augers)
- Printing
- Gyro Testing
- Accelerometer Testing
- Optical Polishing (Spindle Axis)
- Beam Steering

Stent and Medical Device Manufacturing

Aerotech's experience in market-specific solutions provides an edge in processes involving photonics, semiconductor processing, medical device manufacturing and laser processing. With a number of specially developed motion platforms for these industries, Aerotech provides a one-stop-shop for your motion requirements.

Controllers to Use:

- A3200

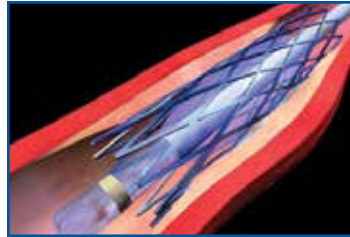

Aerotech's highly successful VascuLathe® and LaserTurn® platforms deliver maximum productivity in a compact, easy to maintain package with the lowest cost of ownership in the industry. With the A3200's PSO functionality, the throughput possible with the LaserTurn® and VascuLathe® series is unmatched.



Solar Panel Scribing

Extensive application experience and a broad array of motion products make Aerotech the perfect partner for your photovoltaic (solar cell) manufacturing or testing platform. Our worldwide operation has engineered and manufactured a multitude of motion platforms for solar cell manufacturing and inspection. These platforms range from small format systems for R&D to full-size production panel processing systems.

Controllers to Use:

- A3200
- Ensemble

- Laser Cutting
- Welding
- Wafer Dicing
- Solar Panel Scribing
- Fuel Injector Drilling
- Turbine Blade Inspection

- Fuel Cell Manufacturing
- 3D Laser Processing
- MRI Machines
- Lab Automation
- Target Tracking
- Optical Testing

Packaging

Line following applications including:

- Labeling, cut-to-length, fly cutting, lane diversion, rotary knife and many others.

Basic features for line following:

- Auxiliary encoder input for measuring line speed
- High-speed registration for measuring line position
- The relationship between line speed/ position can be an arbitrary function or simply 1-to-1

Controllers to Use:

- Soloist
- Ensemble
- A3200

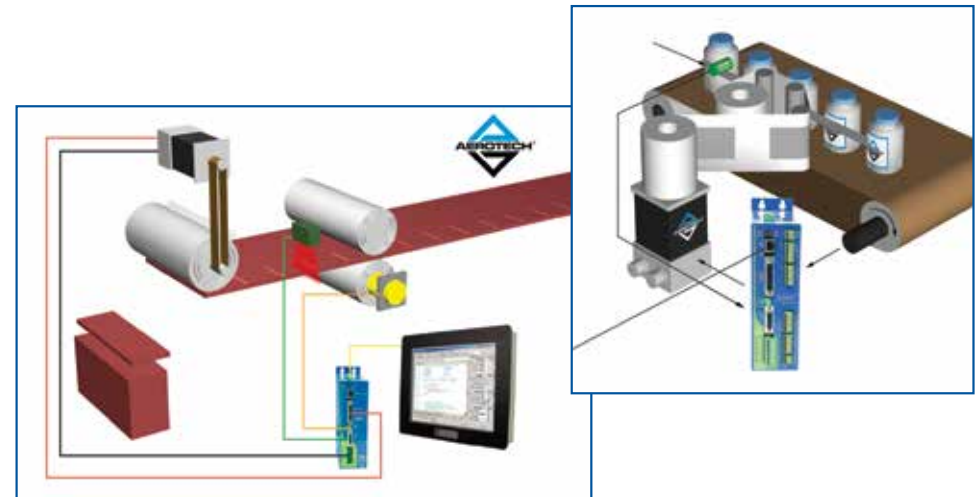

High Accuracy, Multi-Axis Inspection Systems

The A3200 controller is uniquely suited to complex inspection applications like turbine blade inspection that requires 5 axes or more of coordinated motion integrated with a sensor or camera.

Controllers to Use:

- A3200 with linear drives

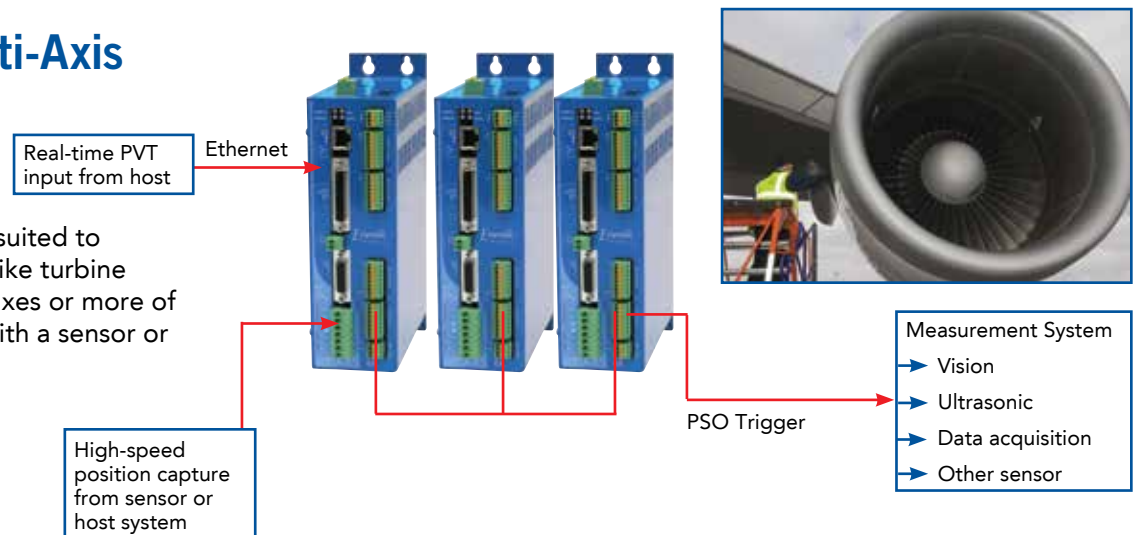

Optical Mounts and Gimbals

- Directing optics, lasers or antennas
- LOS target tracking
- Precision pointing

Controllers to Use:

- A3200
- Ensemble



Fuel Cell Manufacturing Operations

- Laser machining the membranes (also referred to as MEAs)
- Welding the plates/membranes together
- Stacking the membranes into a cell
- Inspection of the MEAs, plates and cells

Controllers to Use:

- A3200

- Gyro Testing
- Reticle Inspection
- Lithography
- Wafer Defect Detection
- Thin Film Measurement
- Pick and Place

Controls Timeline

With 46 years in the business of designing and building motion systems, Aerotech has the experience and knowledge to understand the challenges and solutions of industrial and laboratory processes.

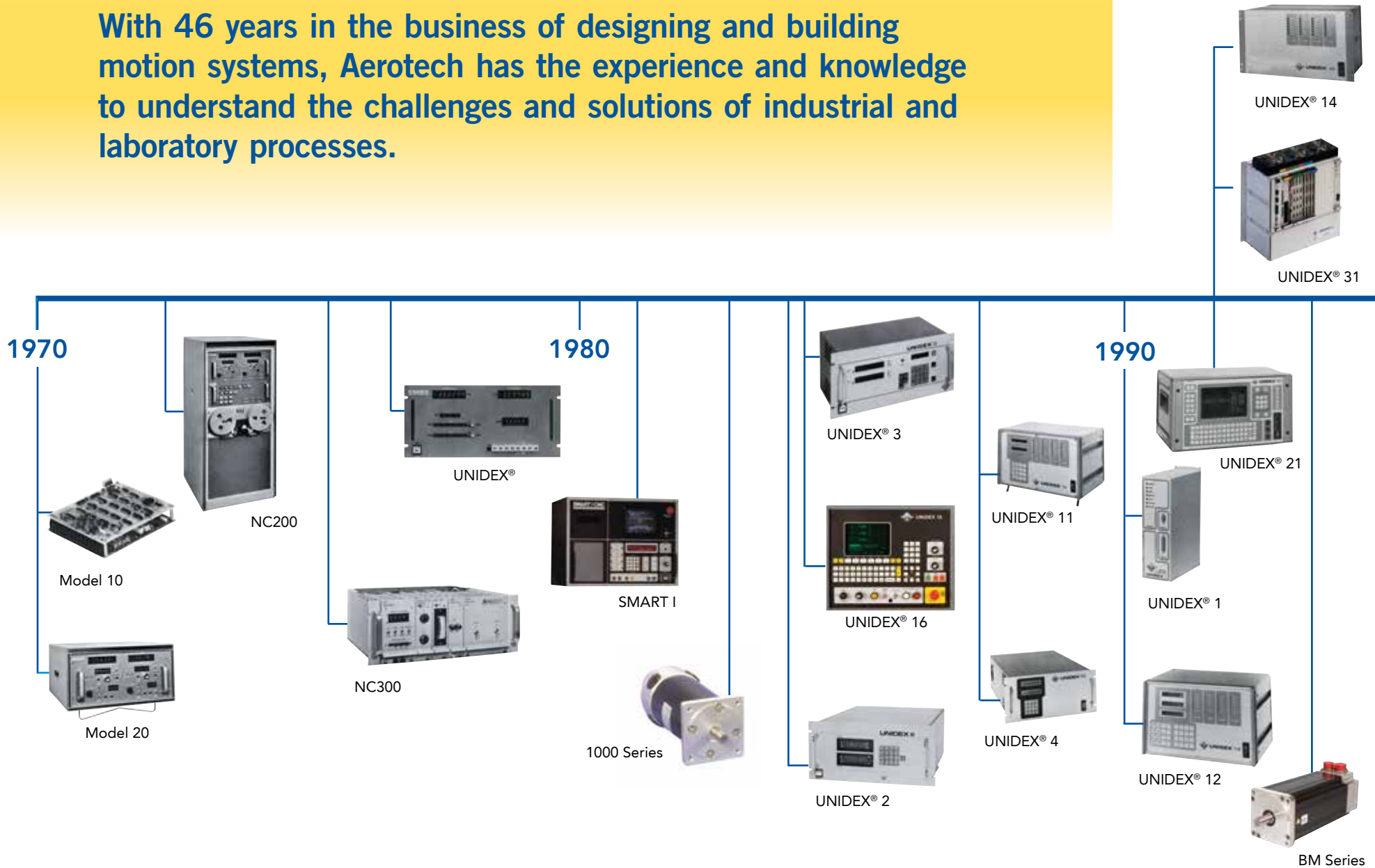



UNIDEX® 500



BLM Series



UNIDEX® 600



A3200®



Integrated Automation
PLC + Motion = MotionPAC



Delta
Robot
Control

PC-Based

2000



UNIDEX® 400



UNIDEX® 511



Soloist®

2010



Ensemble®



Piezo Controls

2016



Hexapod
Control

Stand-Alone



UNIDEX® 100



BAI



BMS Series



S Series

Aerotech has manufactured advanced motion controllers since 1970. From the industry workhorse PCI cards to state-of-the-art software-based control coupled with intelligent networked drives, the science of motion control has been our business for decades.

Aerotech offers comprehensive worldwide training and customer service at customer facilities or at one of our Aerotech training centers.

Training Program:

- Standard and customized courses
- Hands-on training with Aerotech controllers
- Interactive training with experienced instructors
- Comfortable, spacious facilities
- Online training modules
- Online FAQs
- At customer site or at Aerotech

Installation and Startup (Commissioning)

Aerotech offers startup and commissioning services to minimize startup times, reduce costs and accelerate time-to-production. By combining our product knowledge with your process and application expertise, new systems and applications can be completed faster and at a reduced overall cost.

Engineering Support

Aerotech provides complete engineering support for our products, including onsite support and maintenance, and remote support via phone, fax, website and/or WebEx® software. As a manufacturer staffed by engineers, we understand the unacceptability of downtime.

Join.Me.

Aerotech can remotely support your startup, commissioning and debugging of systems over the internet.

Aerotech is an ISO 9001 Registered Company



Aerotech U.S.A.



Aerotech Germany



Aerotech United Kingdom



Aerotech Japan

Since 1995, Aerotech's quality system has been certified to the ISO 9001 standard. The ISO 9001 standard encompasses the Aerotech organization through manufacturing.

As part of our commitment to the ISO standard, we formally survey our customers on a monthly basis which provides valuable feedback to continually improve our products and processes.

Aerotech at a Glance

High-Volume Manufacturing



Over 100,000 axes installed worldwide

This section displays three types of Aerotech components: a stack of linear motor stages at the top, a set of four ADRT rotary stages in the middle, and a large stack of A3200 motion control modules at the bottom.

Worldwide Service and Support



Worldwide startup service and on-site training



Aerotech Worldwide



Fully equipped on-site training facilities

This section illustrates global service and support. It features a technician performing on-site training, a world map with the Aerotech Worldwide logo, and a fully equipped training room with tables and chairs.

Technically Superior Components



Highest performance brushless linear and rotary motors



ADRT rotary stages



ALS1000 linear motor stage



A3200



Soloist®



Ensemble®

Award-winning Automation 3200
1-32 axis motion, vision, PLC, robotics
and I/O platform

This section showcases technically superior components. It includes a collection of brushless linear and rotary motors, ADRT rotary stages, and ALS1000 linear motor stages. It also features three Automation 3200 modules: A3200, Soloist®, and Ensemble®, which are part of an award-winning platform for 1-32 axis motion, vision, PLC, robotics, and I/O.

High Performance Sub-Assemblies



XYAB subsystem for high dynamic accuracy positioning in laser drilling and micromachining applications

HexGen high-load, ultra-precision hexapod provides unmatched performance

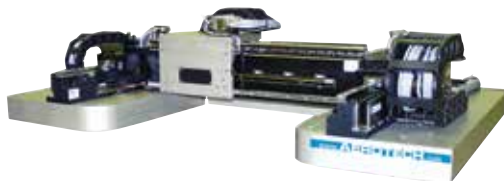

Highest throughput linear motor Cartesian gantry systems

Best-in-Class Subsystems

Highly integrated motion subsystems with machine frame, display and packaged electronics

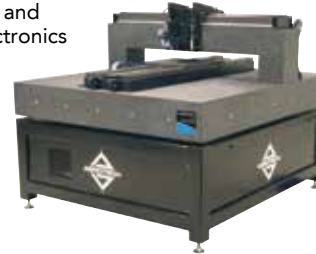

Custom-engineered, vacuum and cleanroom compatible systems



RCP-DELTA robot capable of 15g's of acceleration and up to 200 pick and place operations per minute



Comprehensive Technical Support Services



Custom software application support

3D models to facilitate faster and more accurate system layout

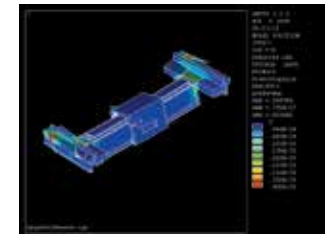
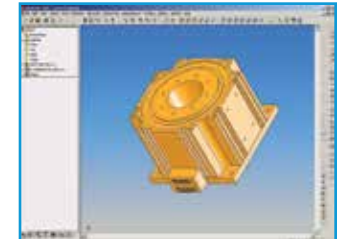

Advanced analytical techniques for optimization of system geometry

Aerotech Worldwide



Corporate Headquarters • Pittsburgh, PA • USA



Aerotech UK



Aerotech Germany



Aerotech Japan



Aerotech China



Aerotech Taiwan

Aerotech Thailand

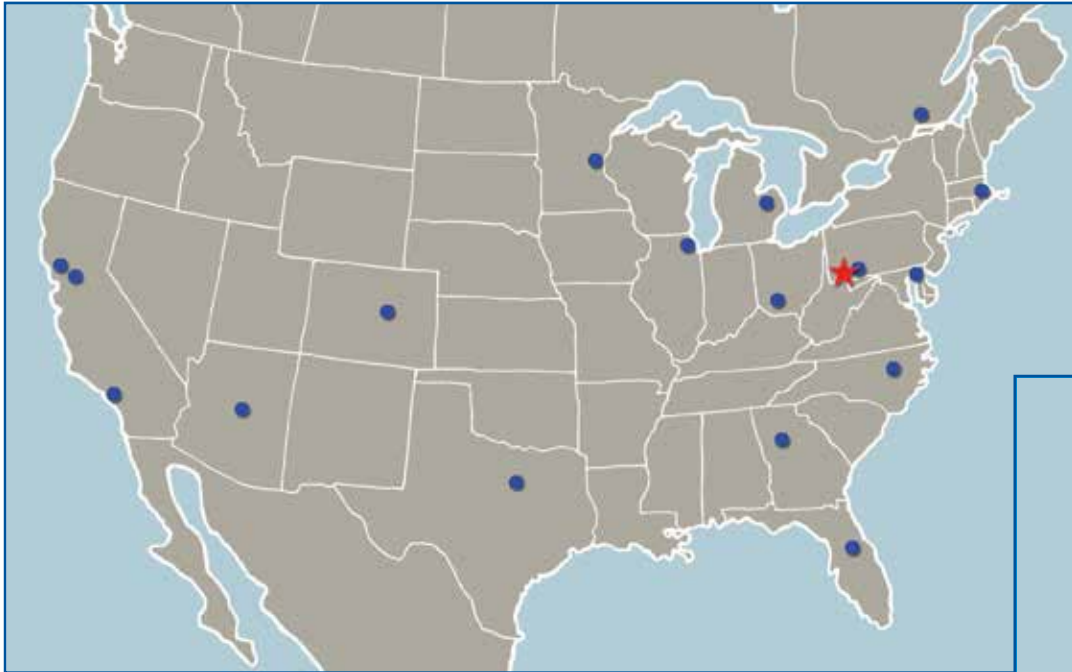

- ★ Aerotech Headquarters
- ▲ Aerotech Subsidiary
- Direct Field Sales Office
- Representative



www.aerotech.com