

 **AEROTECH**
Rotary Stages
Precision in Motion

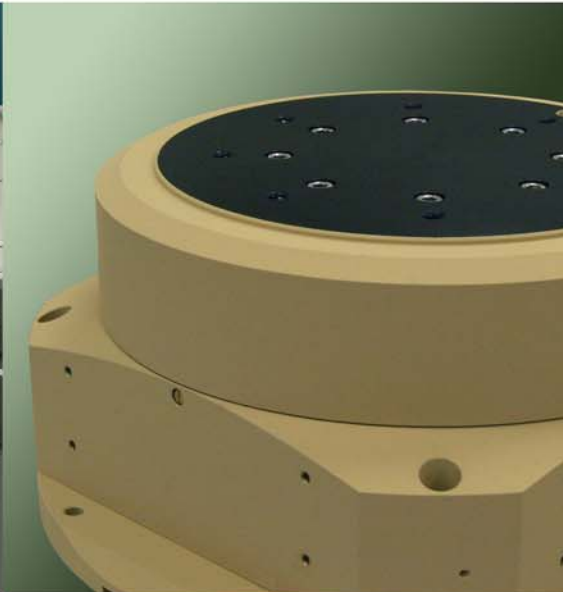

Contents

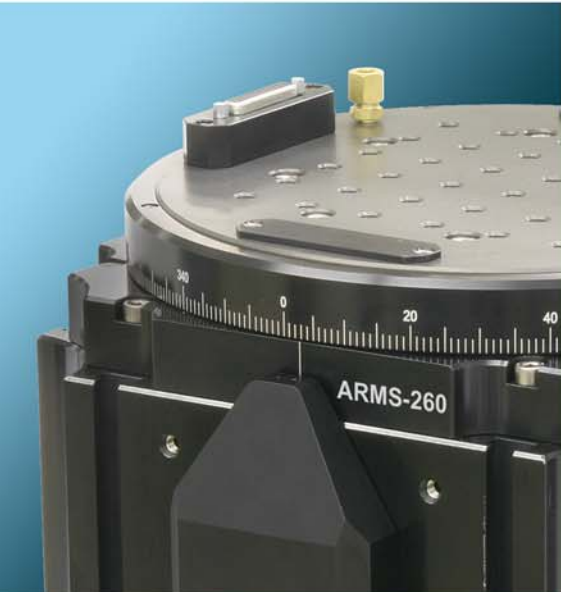

WORLD HEADQUARTERS

Aerotech, Inc.
101 Zeta Drive
Pittsburgh, PA 15238
Ph: 412-963-7470
Fax: 412-963-7459
Email: sales@aerotech.com

Aerotech France
28300 Coltainville
France
Ph: +33 2 37 21 87 65
Fax: +44 (0)1256 855649
Email: cmonnier@aerotech.com

Aerotech Germany
Gustav-Weißkopf-Str. 18
90768 Fürth, Germany
Ph: +49 (0)911 967 9370
Fax: +49 (0)911 967 93720
Email: sales@aerotechgmbh.de

Aerotech United Kingdom
The Old Brick Kiln
Ramsdell, Tadley
Hampshire RG26 5PR
United Kingdom
Ph: +44 (0)1256 855055
Fax: +44 (0)1256 855649
Email: sales@aerotech.co.uk

Aerotech China
Room 101, No. 28 Building
Tianlin Road 140
Xuhui District
Shanghai, China 200234
Ph: +86 (21) 6126 1058
Email: sales@aerotech.com

Aerotech Japan
WBG Marive East 22F
2-6-1 Nakase
Mihama Ward, Chiba
Japan 261-7122
Ph: +81 (0)50 5830 6821
Fax: +81 (0)43 306 3773
Email: sales@aerotechkk.co.jp

Aerotech Taiwan
5F., No.32, Aly. 18, Ln. 478
Ruiguang Road
Neihu District, Taipei City
Taiwan R.O.C.
Ph: +886 (0)2 8751 6690
Email: sales@aerotech.tw

Aerotech Precision Rotary Stages3

Air Bearing, Direct-Drive Rotary Stages

ABRT4

ABRS6

Mechanical Bearing, Direct-Drive Rotary Stages

ADRT8

ADRS10

APR12

ALAR14

ANT95-R18

ANT130-R20

ASRT22

ARMS24

Mechanical Bearing, Gear-Drive Rotary Stage

AGR26

Advanced System Controls28

Aerotech at a Glance30

Aerotech Rotary Calibrator32

Awards and Recognition33

Capabilities in Other Markets34

Aerotech Precision Rotary Stages



ABRS



ABRT



AXR

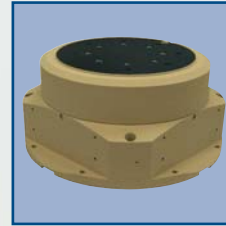

ASRT



ANT95-R

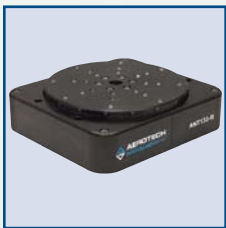

ANT130-R



ASR1000



ADRT



ADRS



APR



ARMS

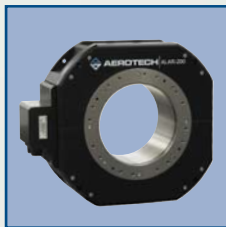

ALAR



ACS



ACS LP



ASR1100

Aerotech manufactures a large selection of rotary stages including direct-drive models that use our own brushless rotary servomotors, as well as worm-gear-driven models. Stages are available with many different size apertures, table diameters and mounting options to provide the ideal solution for your industrial automation application. Wobble and runout performance are outstanding. Aerotech's stages are used in industrial robots, fiberoptics and photonics, vision systems, machine tools, assembly, semiconductor equipment, medical component laser machining, electronic manufacturing and other high-performance industrial automation applications. In addition, Aerotech manufactures drives and motion control solutions that perfectly complement our rotary stages.



ASR1200

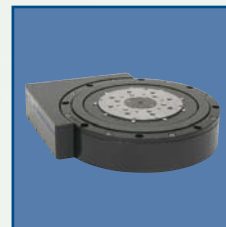

WaferMax T

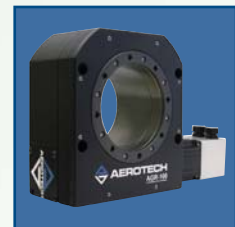

AGR

ABRT

Air Bearing, Direct-Drive Rotary Stage

- High torque output, direct-drive, slotless, brushless servomotor
- Zero cogging motor for outstanding velocity stability
- Outstanding error motion and wobble performance
- Direct coupled, high-accuracy rotary encoder
- Large diameter clear aperture
- No mechanical contact

ABRT series rotary air-bearing stages provide superior angular positioning, velocity stability, and error motion performance along with impressive payload capacity and outstanding radial and axial stiffness. The ABRT is designed to meet the exacting requirements of DVD mastering, wafer inspection, high precision metrology applications, X-ray diffraction systems, optical inspection and fabrication and MEMS/nanotechnology device fabrication.

ABRT Series		ABRT-150	ABRT-200	ABRT-260
Width		146 mm	196 mm	260 mm
Tabletop Diameter		100 mm	145 mm	200 mm
Height		135 mm	165 mm	185 mm
Aperture		20 mm	30 mm	50 mm
Total Travel		360° Continuous		
Motor		Direct-Drive Brushless Servomotor		
Stall Torque, Continuous		0.36 N-m	3.7 N-m	6.7 N-m
Peak Torque		1.4 N-m	14.6 N-m	26.6 N-m
BEMF, Line-Line, Max		10.9 V _{pk} /krpm	163.6 V _{pk} /krpm	129.8 V _{pk} /krpm
Continuous Current, Stall		3.8 A _{pk}	2.7 A _{pk}	6.2 A _{pk}
		2.7 A _{rms}	1.9 A _{rms}	4.4 A _{rms}
Torque Constant		0.09 N-m/A _{pk}	1.35 N-m/A _{pk}	1.07 N-m/A _{pk}
		0.13 N-m/A _{rms}	1.91 N-m/A _{rms}	1.52 N-m/A _{rms}
Bus Voltage		Up to 320 VDC		
Resolution ⁽¹⁾		0.267 μrad (0.055 arc sec)	0.174 μrad (0.036 arc sec)	0.133 μrad (0.027 arc sec)
Fundamental Encoder Resolution		11,840 lines/rev	18,000 lines/rev	23,600 lines/rev
Max Speed ⁽²⁾		1200 rpm	800 rpm	600 rpm
Accuracy ⁽³⁾		±2 arc sec		
Repeatability		<1 arc sec		
Max Load ⁽⁴⁾	Axial	20 kg	41 kg	69 kg
	Radial	3 kg	6 kg	10 kg
	Tilt	3.5 N-m	8 N-m	18 N-m
Axial Error Motion (Synchronous)		<100 nm		
Radial Error Motion (Synchronous)		<150 nm		
Tilt Error Motion (Synchronous)		<2.4 μrad (<0.5 arc-sec)		
Axial Error Motion (Asynchronous)		<20 nm		
Radial Error Motion (Asynchronous)		<20 nm		
Tilt Error Motion (Asynchronous)		<0.2 μrad (<0.04 arc-sec)		
Operating Pressure ⁽⁶⁾		80 psig (5.5 bar) ± 5 psig (0.3 bar)		
Air Consumption ⁽⁷⁾		<56.6 SLPM (<2 SCFM)		
Inertia	Unloaded	2300 kg·mm ²	13,500 kg·mm ²	46,400 kg·mm ²
Total Mass		6.7 kg	14.7 kg	27.1 kg
Material		Aluminum		
Finish		Hardcoat (62 Rockwell Hardness)		

Notes:

1. Maximum resolution presumes A3200 controller using MXH500 multiplication, and accounts for controller quadrature.

2. Maximum speed based on stage capability. Maximum application velocity may be limited by system data rate and system resolution.

3. Certified with each stage. Requires the use of an Aerotech controller.

4. Maximum loads are mutually exclusive.

5. All error motion specifications measured at 60 rpm.

6. To protect air bearing against under-pressure, an in-line pressure switch tied to the motion controller is recommended.

7. Air supply must be clean, dry to 0° F dew point, and filtered to 0.25 μm or better. Recommend nitrogen at 99.9% purity.

ABRT-150

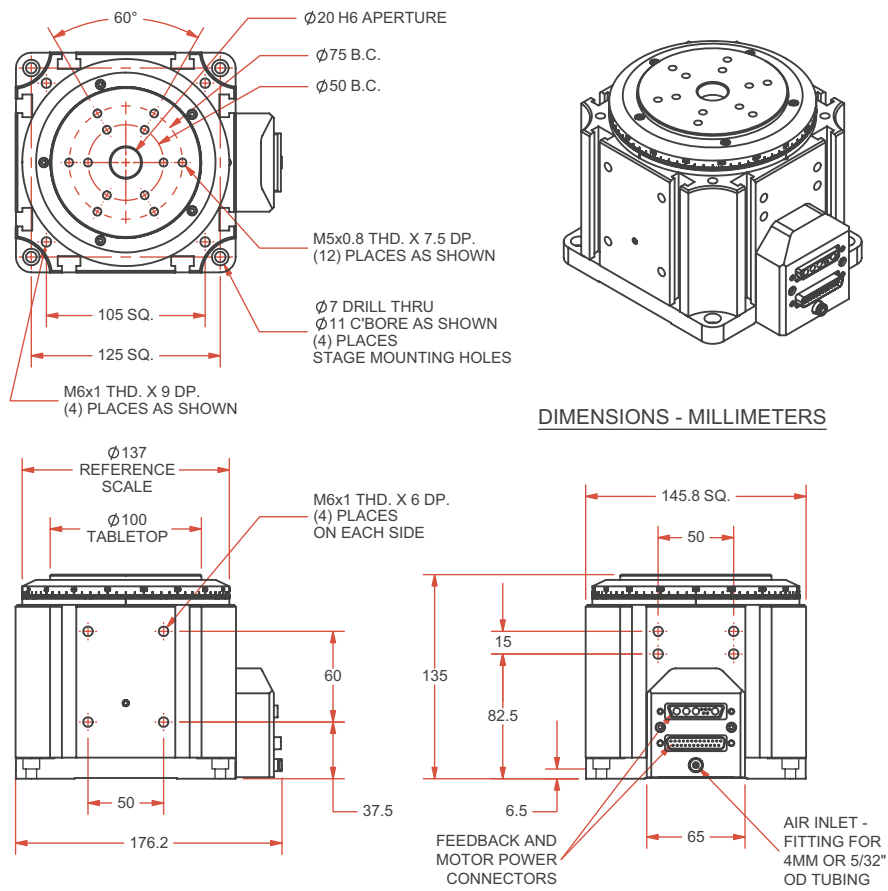

ABRT rotary air-bearing stages feature a large payload and outstanding radial and axial stiffness.

ABRS

Air Bearing, Direct-Drive Rotary Stage

- Direct-drive, slotless, brushless servomotor
- Zero cogging motor for outstanding velocity stability
- Outstanding error motion and wobble performance
- Direct coupled, high accuracy rotary encoder
- Low profile, planar design
- No mechanical contact

ABRS series rotary air-bearing stages provide superior angular positioning, velocity stability and error motion performance in an exceptionally low-profile package. The ABRS is designed to meet the exacting requirements of wafer inspection, high precision metrology, x-ray diffraction systems, optical inspection and fabrication and MEMS/nanotechnology device fabrication. The design of the ABRS series has been optimized to minimize stage height.

ABRS Series	ABRS-150MP	ABRS-200MP	ABRS-250MP	ABRS-300MP	
Width	150 mm	200 mm	250 mm	300 mm	
Tabletop Diameter	128.1 mm	178.1 mm	228.1 mm	278.1 mm	
Height	80 mm	90 mm	100 mm	110 mm	
Aperture	8 mm	20 mm	35 mm	75 mm	
Total Travel	360° Continuous				
Motor	S-50-39-A	S-76-35-A	S-130-39-A	S-180-44-A	
Stall Torque, Continuous	0.20 N-m	0.53 N-m	2.36 N-m	5.99 N-m	
Peak Torque	0.82 N-m	2.12 N-m	9.42 N-m	23.98 N-m	
BEMF, Line-Line, Max	10.3 V _{pk} /Krpm	32.1 V _{pk} /Krpm	75.1 V _{pk} /Krpm	268.7 V _{pk} /Krpm	
Continuous Current, Stall	2.4 A _{pk}	2.0 A _{pk}	3.8 A _{pk}	2.7 A _{pk}	
	1.7 A _{pk}	1.4 A _{pk}	2.7 A _{pk}	1.9 A _{pk}	
Torque Constant	0.09 N-m/A _{pk}	0.26 N-m/A _{pk}	0.62 N-m/A _{pk}	2.22 N-m/A _{pk}	
	0.12 N-m/A _{rms}	0.37 N-m/A _{rms}	0.88 N-m/A _{rms}	3.14 N-m/A _{rms}	
Bus Voltage	80 VDC				
Resolution ⁽¹⁾	0.873 μrad (0.18 arc sec)	0.383 μrad (0.079 arc sec)	0.267 μrad (0.055 arc sec)	0.174 μrad (0.036 arc sec)	
Fundamental Encoder Resolution	3600 lines/rev	8192 lines/rev	11,840 lines/rev	18,000 lines/rev	
Max Speed ⁽²⁾	300 rpm	300 rpm	500 rpm	500 rpm	
Accuracy ⁽³⁾	±3 arc sec		±2 arc sec		
Repeatability (Bi-Directional)	<2 arc sec		<1 arc sec		
Max Load ⁽⁴⁾	Axial	8 kg	31 kg	66 kg	97 kg
	Radial	4 kg	15 kg	36 kg	51 kg
	Tilt	3 N-m	10 N-m	28 N-m	45 N-m
Axial Error Motion (Synchronous)	<175 nm		<100 nm		
Radial Error Motion (Synchronous)	<450 nm		<250 nm		
Tilt Error Motion (Synchronous)	<9.7 μrad (<2.0 arc sec)	<3.4 μrad (<0.7 arc-sec)	<2.4 μrad (<0.5 arc sec)	<2.4 μrad (<0.5 arc sec)	
Axial Error Motion (Asynchronous)	<20 nm				
Radial Error Motion (Asynchronous)	<20 nm				
Tilt Error Motion (Asynchronous)	<0.4 μrad (<0.08 arc sec)	<0.3 μrad (<0.06 arc-sec)	<0.2 μrad (<0.04 arc sec)	<0.2 μrad (<0.04 arc sec)	
Operating Pressure ⁽⁶⁾	80 psig (5.5 bar) + 0 psig (0.0 bar) / - 10 psig (0.7 bar)				
Air Consumption ⁽⁷⁾	<56.6 SLPM (<2 SCFM)				
Inertia	Unloaded	3850 kg-mm ²	13,800 kg-mm ²	39,100 kg-mm ²	102,000 kg-mm ²
Total Mass		4.8 kg	9.1 kg	15.6 kg	24.5 kg
Material	Aluminum				
Finish	Hardcoat (62 Rockwell Hardness)				

Notes:

1. Maximum resolution presumes A3200 controller using MXH500 multiplication, and accounts for controller quadrature.
2. Maximum speed based on stage capability. Maximum application velocity may be limited by system data rate and system resolution.
3. Certified with each stage. Requires the use of an Aerotech controller.
4. Maximum loads are mutually exclusive.
5. All error motion specifications measured at 60 rpm.
6. To protect air bearing against under-pressure, an in-line pressure switch tied to the motion controller is recommended.
7. Air supply must be clean, dry to 0° F dew point, and filtered to 0.25 μm or better. Recommend nitrogen at 99.9% purity.

ABRS-200MP

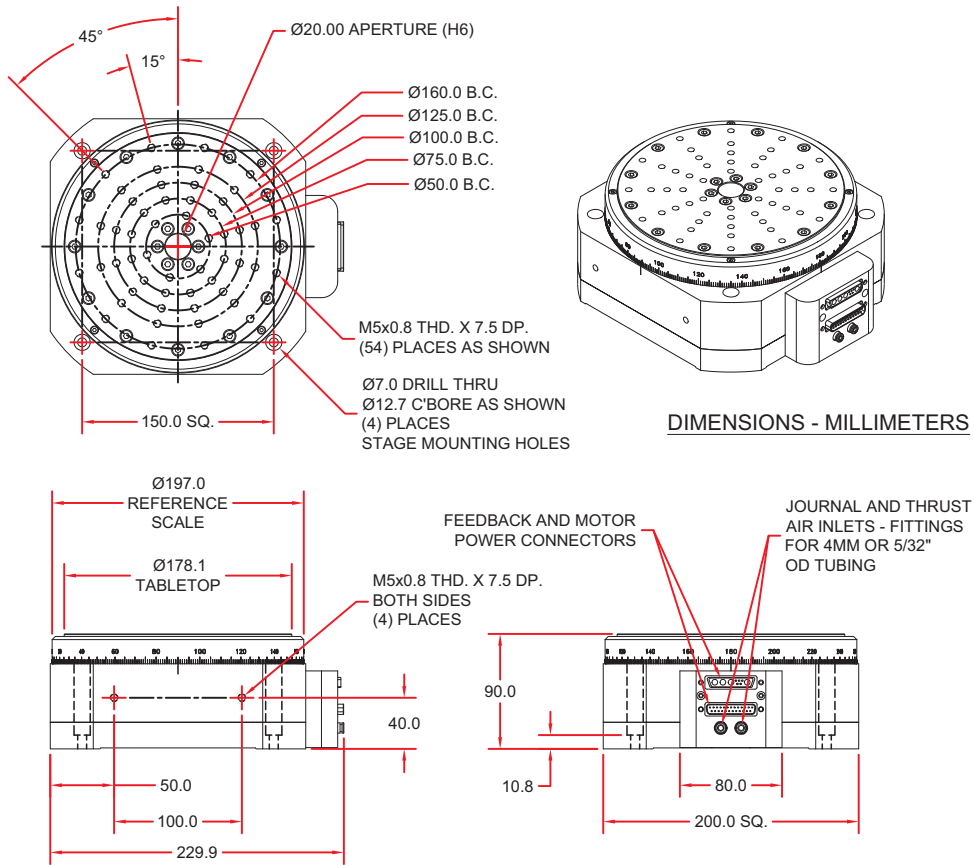

The design of the ABRS series has been optimized to minimize stage height.



ADRT

Mechanical Bearing, Direct-Drive Rotary Stage

- High torque output, direct-drive, brushless servomotor
- Cog-free design for outstanding velocity stability
- Outstanding wobble and runout
- Direct coupled, high-accuracy rotary encoder
- Large diameter clear aperture

ADRT series direct-drive rotary stages provide superior angular positioning and velocity control in applications ranging from indexing to high-speed laser machining to precision wafer inspection. Dual large-diameter bearings are used to maximize performance with respect to wobble, moment stiffness and repeatability. The large diameter bearings permit large payloads without compromising performance.

ADRT Series		ADRT-100-85	ADRT-100-135	ADRT-150-115	ADRT-150-135	ADRT-150-180
Bearing Option		P (Precision)/ S (Standard)				
Continuous Current, Stall	A _{pk}	2.0	3.7	3.8	3.4	3.1
	A _{rms}	1.43	2.6	2.7	2.4	2.2
Motor Type		S176135A	S176185A	S1130139A	S1130160A	S1130102A
Bus Voltage		Up to 320 VDC				
Accuracy ⁽¹⁾		5 arc sec (P) 60 arc sec (S)				
Repeatability		3 arc sec				
Axial Error Motion		5 μm (P) 10 μm (S)				
Radial Error Motion ⁽²⁾		5 μm (P) 10 μm (S)				
Tilt Error Motion		10 arc sec				
Height		85 mm	135 mm	115 mm	135 mm	180 mm
Aperture		13 mm			50 mm	
Resolution		0.873/87.3 μrad (0.18/18 arc sec)				
Radial Load ⁽³⁾		10 kg			25 kg	
Axial Load		15 kg			30 kg	
Rated Speed		1000 rpm (S) 1500 rpm (P)			600 rpm	
Inertia		0.00028 kg·m ²	0.00067 kg·m ²	0.003379 kg·m ²	0.004958 kg·m ²	0.008118 kg·m ²
Mass		2.3 kg	2.9 kg	5.3 kg	6.9 kg	10.2 kg
Finish	Table	Hardcoat				
	Stage	Black Anodize				
ADRT Series		ADRT-200-155	ADRT-200-185	ADRT-260-160	ADRT-260-180	
Bearing Option		P (Precision)/ S (Standard)				
Continuous Current, Stall	A _{pk}	5.1	4.9	5.9	5.8	
	A _{rms}	3.6	3.5	4.2	4.1	
Motor Type		S1180169A	S1180194A	S1240163A	S1240183A	
Bus Voltage		Up to 320 VDC				
Accuracy ⁽¹⁾		5 arc sec (P) 60 arc sec (S)				
Repeatability		3 arc sec				
Axial Error Motion		5 μm (P) 10 μm (S)				
Radial Error Motion ⁽²⁾		5 μm (P) 10 μm (S)				
Tilt Error Motion		10 arc sec				
Height		155 mm			160 mm	
Aperture		75 mm			100 mm	
Resolution		0.582/58.2 μrad (0.12/12 arc sec)				
Radial Load ⁽³⁾		80 kg			110 kg	
Axial Load		140 kg			170 kg	
Rated Speed		500 rpm			375 rpm	
Inertia		0.020991 kg·m ²	0.027666 kg·m ²	0.066488 kg·m ²	0.08566 kg·m ²	
Mass		13.4 kg	16.7 kg	25.4 kg	30.6 kg	
Finish	Table	Hardcoat				
	Stage	Black Anodize				

Note:

1. P accuracy requires calibration and Aerotech controls.

2. Specifications are for single axis systems. Performance of multi axis systems is payload and workpoint dependent. Consult factory for multi axis or nonstandard applications.

3. Moment load based on 5 year continuous rotation at 250 rpm with maximum axial load applied. Larger moment loads possible for low speed and/or low duty cycle applications. Consult Aerotech for additional information.

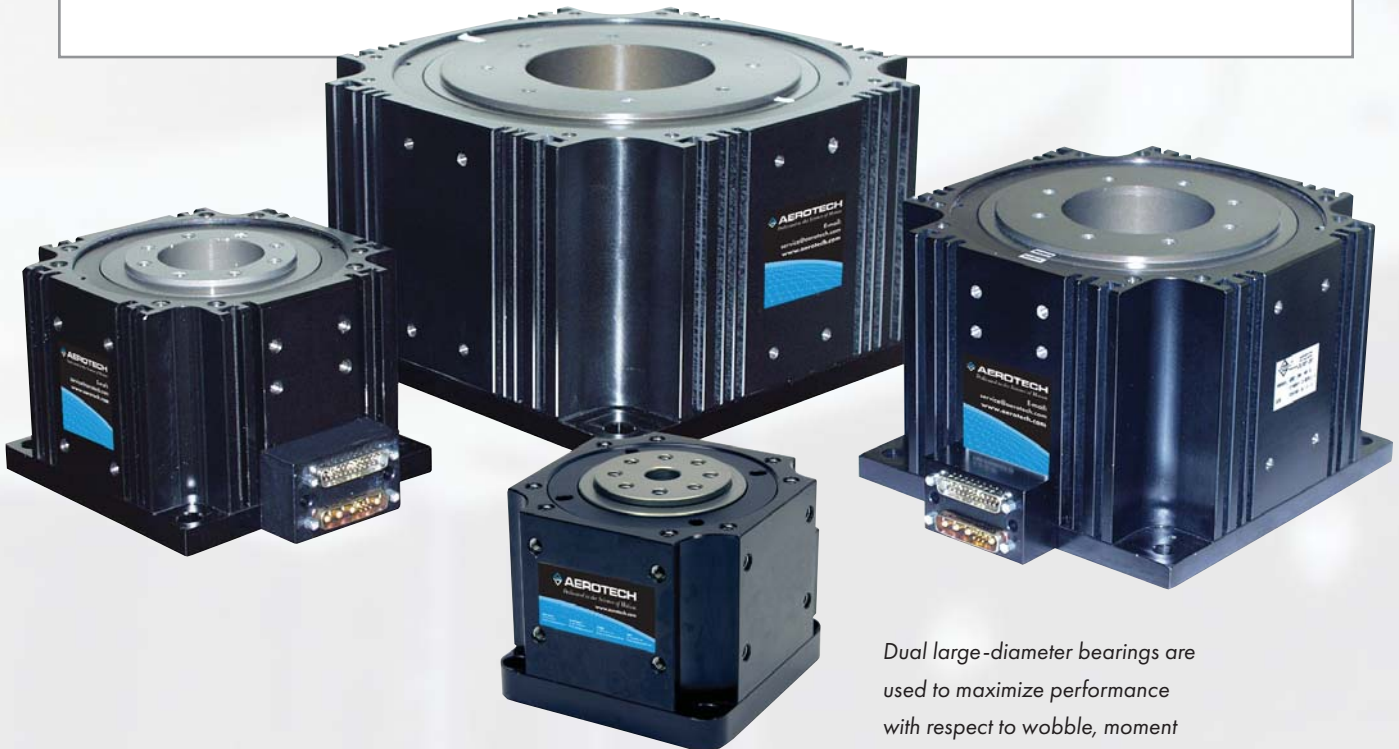
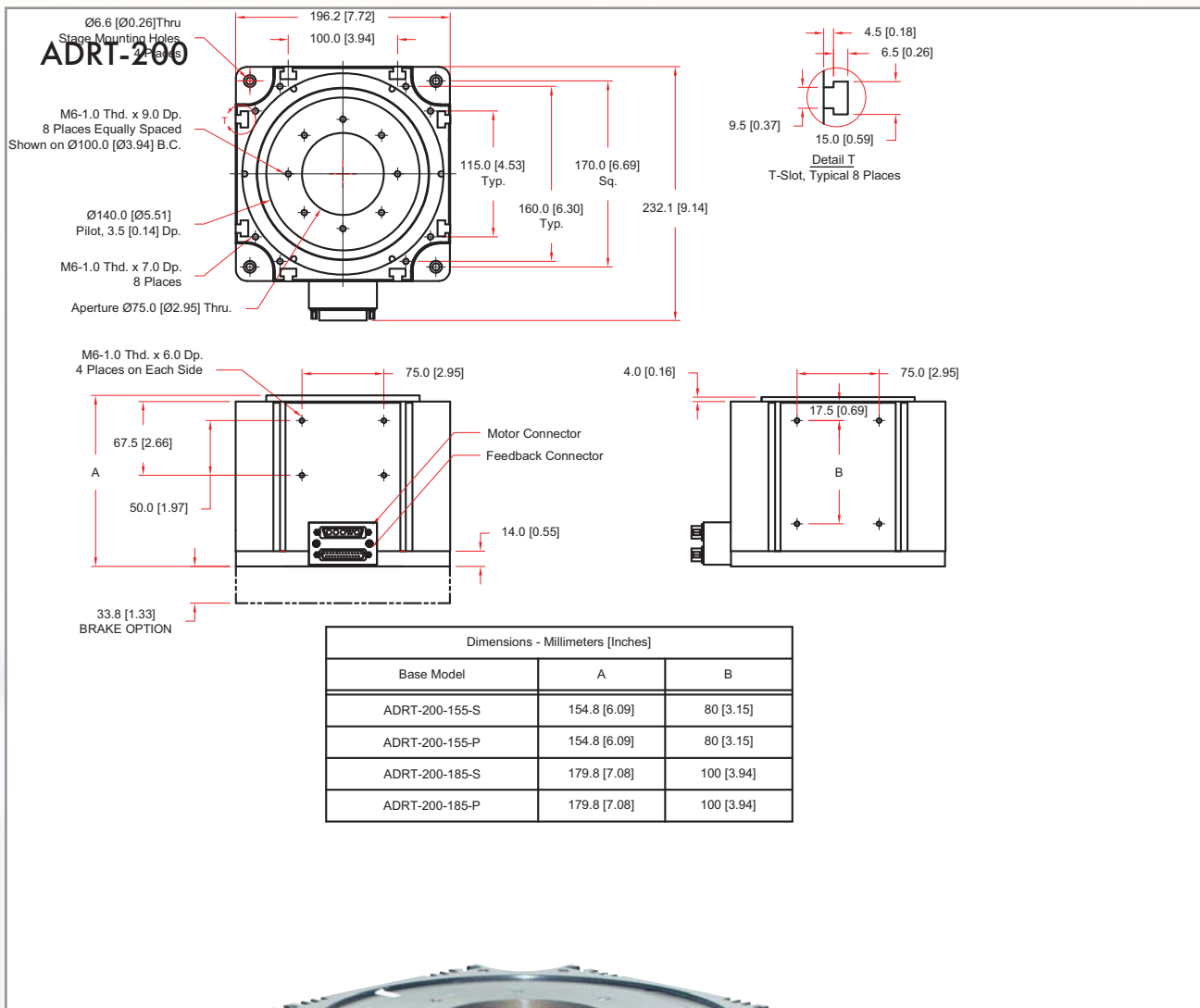

Dual large-diameter bearings are used to maximize performance with respect to wobble, moment stiffness, and repeatability.

ADRS

Mechanical Bearing, Direct-Drive Rotary Stage

- High torque output, direct-drive, brushless servomotor
- Cog-free slotless motor design for outstanding velocity stability
- Direct coupled, high-accuracy rotary encoder
- Ultra-low-profile minimizes working height

The design of the ADRS series direct-drive rotary stage was optimized to minimize stage height. The low profile of the stage reduces the effective working height of the system minimizing “stack-up” related errors. In addition to the low overall height, the ADRS series provides a clear aperture that can be used for product feed-through or laser beam delivery. The low maintenance and high-throughput of the ADRS series provide a stage that yields the lowest total cost of ownership.

ADRS Series		ADRS-100		ADRS-150		ADRS-200	
Tabletop Diameter		95 mm		140 mm		190 mm	
Aperture		6 mm		15 mm		26 mm	
Motor (-A/-B)		S-76-35-A	S-76-35-B	S-130-39-A	S-130-39-B	S-180-44-A	S-180-44-B
Continuous Current, Stall	A_{pk}	2	4	3.8	7.6	2.7	5.3
	A_{rms}	1.4	2.8	2.7	5.4	1.9	3.8
Bus Voltage		320	160	320	160	320	160
Resolution		0.87-87.3 μ rad (0.18-18 arc sec)		0.315-31.5 μ rad (0.065-6.5 arc sec)			
Max Speed ⁽¹⁾		1500 rpm		600 rpm		400 rpm	
Accuracy	Uncalibrated	388 μ rad (80 arc sec)					
	Calibrated ⁽²⁾	29.1 μ rad (6 arc sec)					
Repeatability		14.6 μ rad (3 arc sec)					
Max Load ⁽³⁾	Axial	7 kg		20 kg		40 kg	
	Radial	3 kg		10 kg		20 kg	
Axial Error Motion ⁽⁴⁾		2 μ m		5 μ m		5 μ m	
Radial Error Motion ⁽⁴⁾		3 μ m		5 μ m		5 μ m	
Tilt Error Motion		48.5 μ rad (10 arc sec)					
Inertia	Unloaded	0.00038 kg-m ²		0.00242 kg-m ²		0.00843 kg-m ²	
Total Mass		2.0 kg		4.3 kg		7.6 kg	
Finish	Tabletop	Hardcoat					
	Stage	Black Anodize					

Notes:

1. Maximum speed is based on stage capability. Actual speed may depend on encoder resolution, load, amplifier bus voltage, and motor. See the S-series rotary motor for more information.

2. With HALAR.

3. Maximum loads are mutually exclusive.

4. For the ADRS-100, error motion specifications are below 700 rpm. Above 700 rpm, the max radial error is 5 microns. Errors measured 25 mm above the tabletop.

ADRS-150

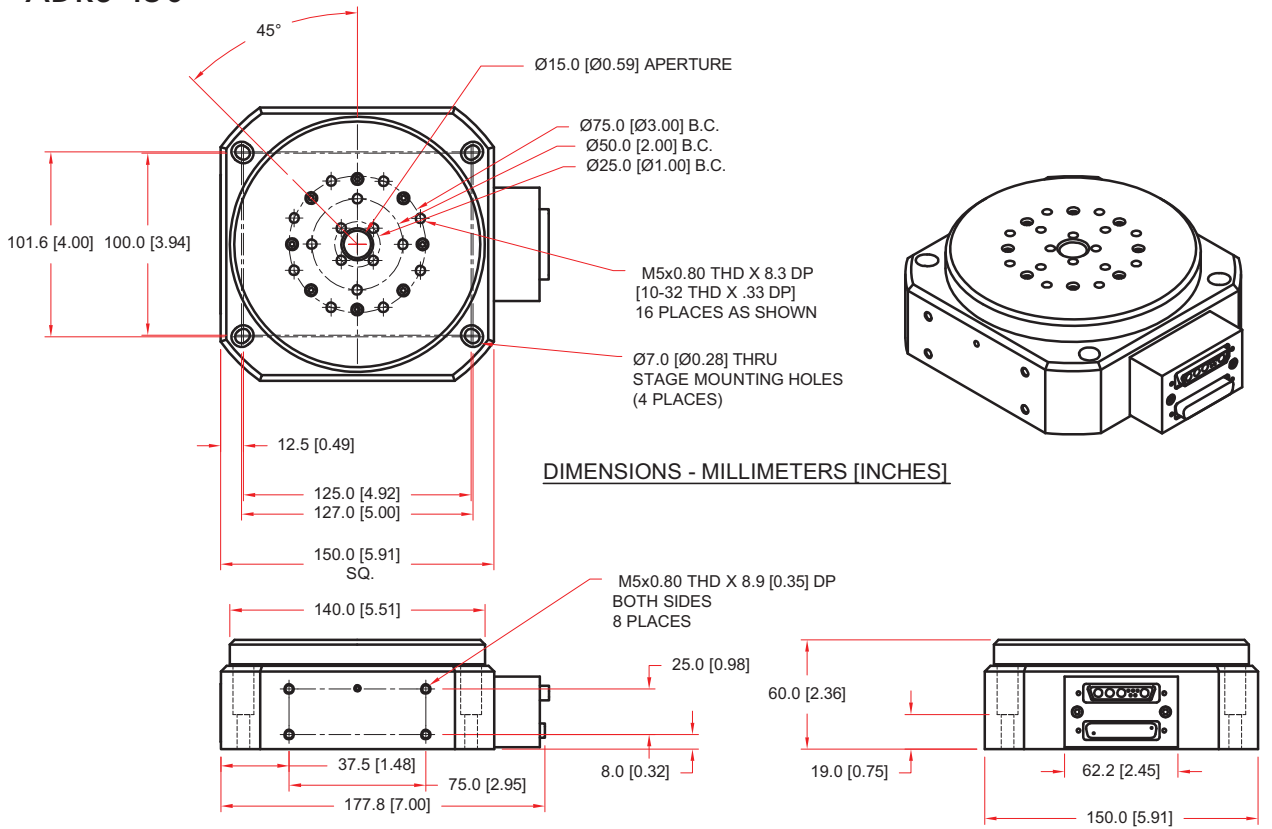

The low maintenance and high-throughput of the ADRS series provide a stage that yields the lowest total cost of ownership.



APR

Mechanical Bearing, Direct-Drive Rotary Stage

- Up to 1.5 arc-second accuracy
- Axial load capacity up to 450 kg
- Incremental or absolute encoders
- Large bearings provide high payload and moment load capacity
- 375-800 rpm continuous rotation speed
- Seven models are available, each with either 50, 75 or 100 mm clear aperture

APR series direct-drive rotary stages are excellent for high-accuracy rotary positioning. The precision-machined and ground stage parts coupled with high-precision angular contact bearings result in exceptionally low error motions, accuracy errors and repeatability errors. In addition, high resolution optical encoders provide excellent pointing capability with low-jitter velocity tracking. APR stages are perfect for rotary testing, pointing, optical calibration systems and metrology systems.

APR Series		APR200DR-155	APR200DR-185	APR260DR-160	APR260DR-180
Travel		Continuous (Optional 270° Max Limited)			
Accuracy	Standard	Uncalibrated	33 arc sec		25 arc sec
		Calibrated	3 arc sec		2 arc sec
	High Accuracy	Uncalibrated	3 arc sec		2 arc sec
		Calibrated	1.75 arc sec		1.50 arc sec
Resolution (Min. Mechanical Step)		0.06 arc sec		0.04 arc sec	
Repeatability (Bi-Directional) ⁽¹⁾		1.00 arc sec		0.75 arc sec	
Repeatability (Uni-Directional)		0.50 arc sec		0.50 arc sec	
Total Tilt Error Motion ⁽¹⁾		2.00 arc sec			
Total Axial Error Motion ⁽¹⁾		1.50 μm			
Total Radial Error Motion ⁽¹⁾		1.50 μm			
Maximum Speed ⁽³⁾	-A	500 rpm		375 rpm	
	-B	700 rpm		N/A	
Maximum Acceleration		380 rad/s ²	440 rad/s ²	175 rad/s ²	215 rad/s ²
Aperture		75 mm		100 mm	
Maximum Torque (Continuous)		11.12 Nm	15.93 Nm	19.71 Nm	29.09 Nm
Load Capacity	Axial	205 kg		250 kg	
	Radial	100 kg		135 kg	
Rotor Inertia (Unloaded)		0.026 kg-m ²	0.032 kg-m ²	0.10 kg-m ²	0.12 kg-m ²
Stage Mass ⁽⁴⁾		17.8 kg	22 kg	29.8 kg	35.4 kg
Material		Aluminum; Hardcoat/Anodize Finish			
MTBF (Mean Time Between Failure)		20,000 hours			

Notes:

1. Certified with each stage.
2. All error motion specifications are measured at 60 rpm.
3. Maximum speed listed is stage and motor dependent (assuming a 340 V bus). Actual speed may be lower due to motor back emf or encoder bandwidth (see Encoder Bandwidth table). Consult an Aerotech Applications Engineer for more details.
4. Mass listed is for the standard stage option (no brake and no tabletop). Consult Aerotech if brake and tabletop masses are desired.

APR200

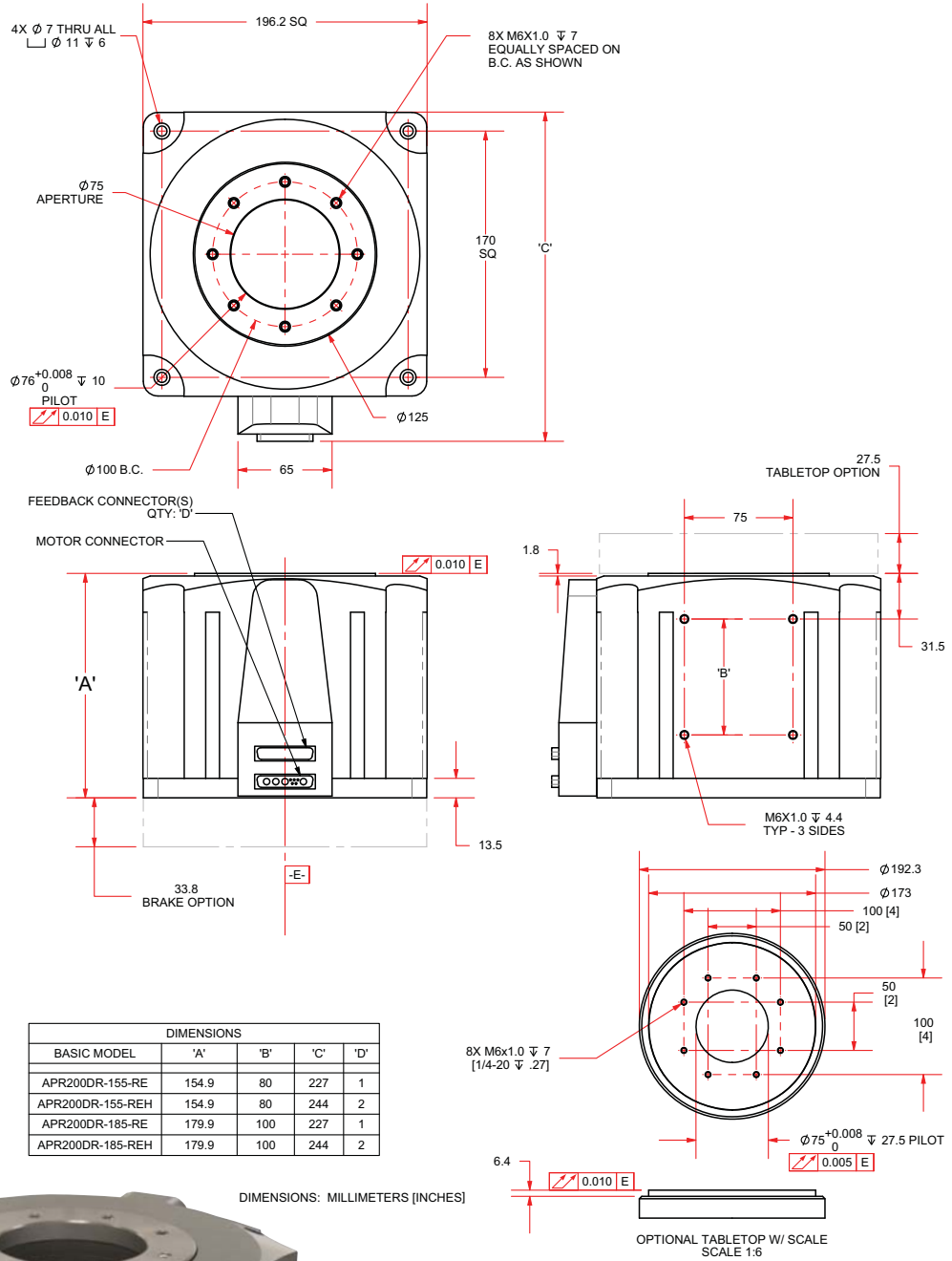

DIMENSIONS				
BASIC MODEL	'A'	'B'	'C'	'D'
APR200DR-155-RE	154.9	80	227	1
APR200DR-155-REH	154.9	80	244	2
APR200DR-185-RE	179.9	100	227	1
APR200DR-185-REH	179.9	100	244	2

DIMENSIONS: MILLIMETERS [INCHES]



APR stages are perfect for rotary testing, pointing, optical calibration systems and metrology systems.

ALAR

Mechanical Bearing, Direct-Drive Rotary Stage

- 5 different aperture sizes: 100 mm, 150 mm, 200 mm, 250 mm, 325 mm
- Continuous or limited travel
- Axial load capacity up to 595 kg
- Large bearings provide high payload and moment load capacity
- Excellent accuracy and repeatability
- No accuracy changes over time from gear wear
- 45-300 rpm continuous rotation speed
- Vac 10^{-6} torr compatible versions available

Aerotech's ALAR series direct-drive rotary stages provide superior angular positioning and velocity control with exceptionally large apertures. With the combination of a large aperture and direct-drive motor, the ALAR series makes worm-drive large aperture stages a thing of the past. ALAR stages can operate between 45-300 rpm depending on the particular model selected. This speed range is significantly higher than gear-drive stages of similar size.



ALAR Series	ALAR-100-SP	ALAR-100-LP	ALAR-150-SP	ALAR-150-LP
Aperture	100 mm (3.94 in)	100 mm (3.94 in)	150 mm (5.91 in)	150 mm (5.91 in)
Motor	S-180-44-A	Brushless Slotless	S-240-43-A	Brushless Slotless
Continuous Current	A_{pk}	2.7	5.76	6.2
	A_{rms}	1.9	4.1	4.4
Peak Current, Stall	A_{pk}	10.8	33.5	24.8
	A_{rms}	7.6	23.7	17.5
Bus Voltage	Up to 340 VDC			
Length	250 mm (9.84 in)	250 mm (9.84 in)	300 mm (11.81 in)	300 mm (11.81 in)
Width	250 mm (9.84 in)	250 mm (9.84 in)	300 mm (11.81 in)	300 mm (11.81 in)
Height	100 mm (3.94 in)	65 mm (2.56 in)	100 mm (3.94 in)	65 mm (2.56 in)
Unlimited Travel	Yes			
Maximum Limited Travel	$\pm 170^\circ$	$\pm 170^\circ$	$\pm 170^\circ$	$\pm 170^\circ$
Maximum Velocity @ 160 V Bus ⁽¹⁾	300 rpm	50 rpm	250 rpm	45 rpm
Maximum Acceleration	1364 rad/s ²	1009 rad/s ²	1330 rad/s ²	829 rad/s ²
Resolution ⁽²⁾	0.1 μ rad (0.02 arc-sec)	0.1 μ rad (0.02 arc-sec)	0.08 μ rad (0.016 arc-sec)	0.09 μ rad (0.018 arc-sec)
Maximum Torque	23.9 N-m (211.5 lb-in)	11.9 N-m (105.3 lb-in)	42.9 N-m (379.7 lb-in)	15.4 N-m (136.3 lb-in)
Continuous Torque	6.0 N-m (53.1 lb-in)	2.0 N-m (17.7 lb-in)	10.7 N-m (94.7 lb-in)	2.6 N-m (23.0 lb-in)
Stage Mass	16.3 kg	8.3 kg	18.6 kg	9.8 kg
Stage Mass with Limits	17 kg	8.9 kg	19.6 kg	10.8 kg
Shaft Inertia	0.022 kg-m ²	0.022 kg-m ²	0.040 kg-m ²	0.031 kg-m ²
Shaft Inertia with Limits	0.026 kg-m ²	0.026 kg-m ²	0.051 kg-m ²	0.042 kg-m ²
Axial Load	1550 N (348 lb)	1175 N (264 lb)	1950 N (438 lb)	1325 N (298 lb)
Radial Load	1350 N (303 lb)	950 N (214 lb)	1925 N (433 lb)	1275 N (287 lb)
Moment Load	250 N-m	150 ⁽³⁾ N-m	450 N-m	225 ⁽³⁾ N-m
Repeatability	$\pm 2.4 \mu$ rad (± 0.5 arc sec)			
Accuracy ⁽⁴⁾	$\pm 9.7 \mu$ rad (± 2 arc sec)			
Tilt-Error Motion	9.7 μ rad (2.0 arc sec)			

Note:

1. Square-wave digital encoder options will limit maximum speed below the listed value. Contact factory for specific stage and encoder speed combination.
2. Resolution assumes -AS encoder with 2000X controller multiplication.
3. The ALAR-LP base must be fully supported by a rigid mounting plate to achieve this moment load.
4. Certified with each stage. Requires the use of an Aerotech controller.

ALAR Series		ALAR-200-SP	ALAR-200-LP	ALAR-250-SP-2	ALAR-250-SP-3	ALAR-250-LP
Aperture		200 mm (7.87 in)	200 mm (7.87 in)	250 mm (9.84 in)	250 mm (9.84 in)	250 mm (9.84 in)
Motor		Brushless Slotless				
Continuous Current	A _{pk}	5.3	5.3	5.3	7.95	5.3
	A _{rms}	3.75	3.75	3.75	5.62	3.75
Peak Current, Stall	A _{pk}	34.8	34.8	34.8	52.2	34.8
	A _{rms}	24.6	24.6	24.6	36.9	24.6
Bus Voltage		Up to 340 VDC				
Length		400 mm (15.75 in)	400 mm (15.75 in)	450 mm (17.72 in)	450 mm (17.72 in)	450 mm (17.72 in)
Width		400 mm (15.75 in)	400 mm (15.75 in)	450 mm (17.72 in)	450 mm (17.72 in)	450 mm (17.72 in)
Height		150 mm (5.91 in)	100 mm (3.94 in)	150 mm (5.91 in)	150 mm (5.91 in)	100 mm (3.94 in)
Unlimited Travel		Yes				
Maximum Limited Travel		±170°	±170°	±170°	±170°	±170°
Maximum Velocity ⁽¹⁾		90 rpm	90 rpm	140 rpm	140 rpm	90 rpm
Maximum Acceleration		361 rad/s ²	570 rad/s ²	287 rad/s ²	287 rad/s ²	407 rad/s ²
Resolution ⁽²⁾		0.06 μrad (0.012 arc-sec)	0.07 μrad (0.014 arc-sec)	0.05 μrad (0.01 arc-sec)	0.05 μrad (0.01 arc-sec)	0.05 μrad (0.01 arc-sec)
Maximum Torque		86 N-m (761.2 lb-in)	86 N-m (761.2 lb-in)	92 N-m (814.3 lb-in)	138 N-m (1221.4 lb-in)	92 N-m (814.3 lb-in)
Continuous Torque		12.9 N-m (114.2 lb-in)	12.9 N-m (114.2 lb-in)	14.1 N-m (124.8 lb-in)	21.1 N-m (186.8 lb-in)	14.1 N-m (124.8 lb-in)
Stage Mass		40.4 kg	28.2 kg	51.3 kg	51.3 kg	35.0 kg
Stage Mass with Limits		43.1 kg	30.1 kg	54.5 kg	54.5 kg	37.4 kg
Shaft Inertia		0.320 kg-m ²	0.190 kg-m ²	0.500 kg-m ²	0.500 kg-m ²	0.310 kg-m ²
Shaft Inertia with Limits		0.359 kg-m ²	0.229 kg-m ²	0.573 kg-m ²	0.573 kg-m ²	0.383 kg-m ²
Axial Load		4675 N (1051 lb)	4350 N (978 lb)	4950 N (1113 lb)	4950 N (1113 lb)	4950 N (1113 lb)
Radial Load		4775 N (1073 lb)	4125 N (927 lb)	5200 N (1169 lb)	5200 N (1169 lb)	5050 N (1135 lb)
Moment Load		1600 N-m	1075 ⁽³⁾ N-m	1825 N-m	1825 N-m	1475 ⁽³⁾ N-m
Repeatability		±2.4 μrad (±0.5 arc sec)				
Accuracy ⁽⁴⁾		±9.7 μrad (±2 arc sec)				
Tilt-Error Motion		9.7 μrad (2.0 arc sec)				
ALAR Series		ALAR-325-SP-2		ALAR-325-SP-3		ALAR-325-LP
Aperture		325 mm (12.80 in)		325 mm (12.80 in)		325 mm (12.80 in)
Motor		Brushless Slotless				
Continuous Current	A _{pk}	5.1		7.65		5.1
	A _{rms}	3.63		5.41		3.63
Peak Current, Stall	A _{pk}	31.2		46.8		31.2
	A _{rms}	22.1		33.1		22.1
Bus Voltage		Up to 340 VDC				
Length		525 mm (20.67 in)		525 mm (20.67 in)		525 mm (20.67 in)
Width		525 mm (20.67 in)		525 mm (20.67 in)		525 mm (20.67 in)
Height		150 mm (5.91 in)		150 mm (5.91 in)		100 mm (3.94 in)
Unlimited Travel		Yes				
Maximum Limited Travel		±170°		±170°		±170°
Maximum Velocity ⁽¹⁾		150 rpm		150 rpm		120 rpm
Maximum Acceleration		185 rad/s ²		185 rad/s ²		339 rad/s ²
Resolution ⁽²⁾		0.04 μrad (0.009 arc-sec)		0.04 μrad (0.009 arc-sec)		0.04 μrad (0.009 arc-sec)
Maximum Torque		143 N-m (1265.7 lb-in)		214.9 N-m (1902.0 lb-in)		143 N-m (1265.7 lb-in)
Continuous Torque		23.4 N-m (207.1 lb-in)		35.1 N-m (310.7 lb-in)		23.4 N-m (207.1 lb-in)
Stage Mass		61.2 kg		61.2 kg		44.5 kg
Stage Mass with Limits		64.9 kg		64.9 kg		49.9 kg
Shaft Inertia		1.01 kg-m ²		1.01 kg-m ²		0.55 kg-m ²
Shaft Inertia with Limits		1.2 kg-m ²		1.2 kg-m ²		0.675 kg-m ²
Axial Load		5825 N (1310 lb)		5825 N (1310 lb)		5825 N (1310 lb)
Radial Load		6650 N (1495 lb)		6650 N (1495 lb)		6450 N (1450 lb)
Moment Load		2650 N-m		2650 N-m		2200 ⁽³⁾ N-m
Repeatability		±2.4 μrad (±0.5 arc sec)				
Accuracy ⁽⁴⁾		±9.7 μrad (±2 arc sec)				
Tilt-Error Motion		9.7 μrad (2.0 arc sec)				

Note:

1. Square-wave digital encoder options will limit maximum speed below the listed value. Contact factory for specific stage and encoder speed combination.
2. Resolution assumes -AS encoder with 2000X controller multiplication.
3. The ALAR-LP base must be fully supported by a rigid mounting plate to achieve this moment load.
4. Certified with each stage. Requires the use of an Aerotech controller.

ALAR-150-SP

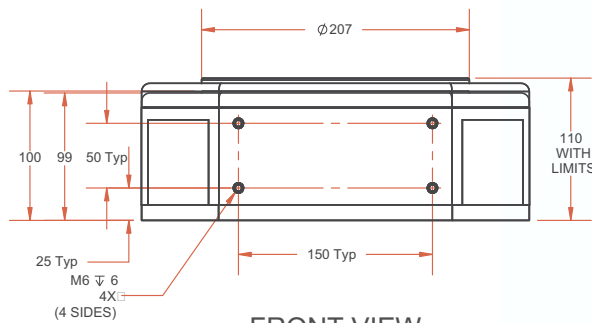
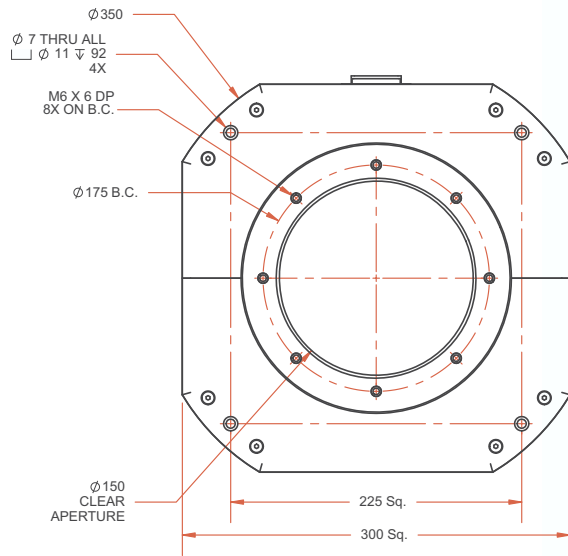

FRONT VIEW

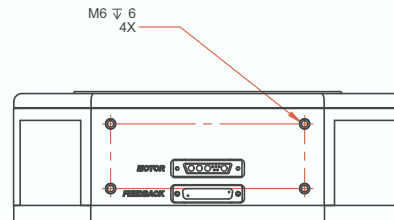

BACK VIEW
(NOT A PROJECTED VIEW)

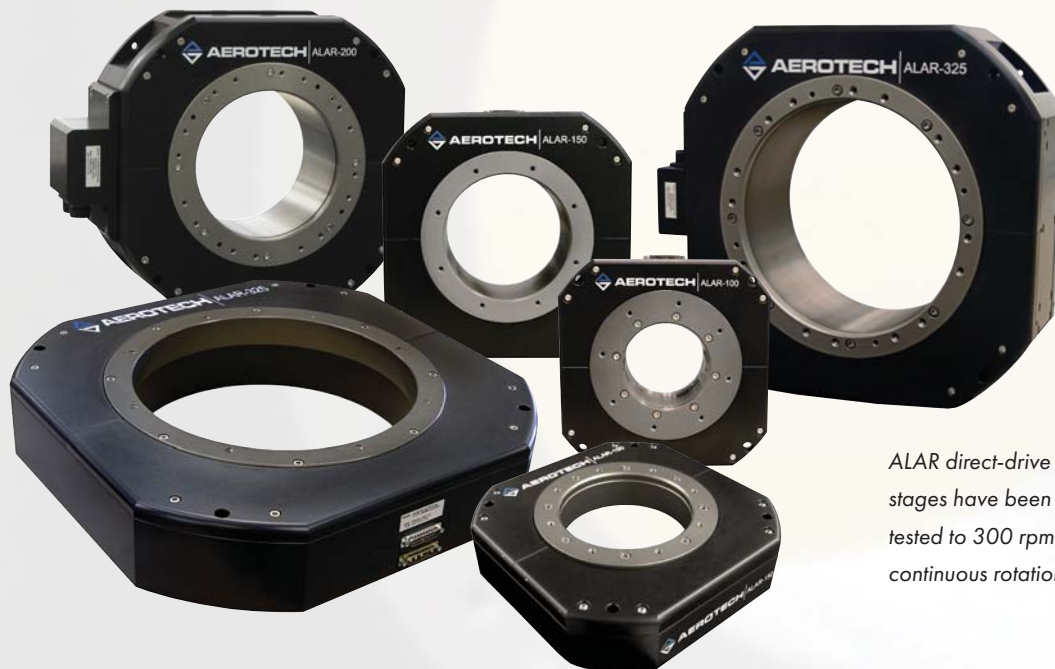

ALAR direct-drive stages have been tested to 300 rpm continuous rotation.

ALAR-325-LP

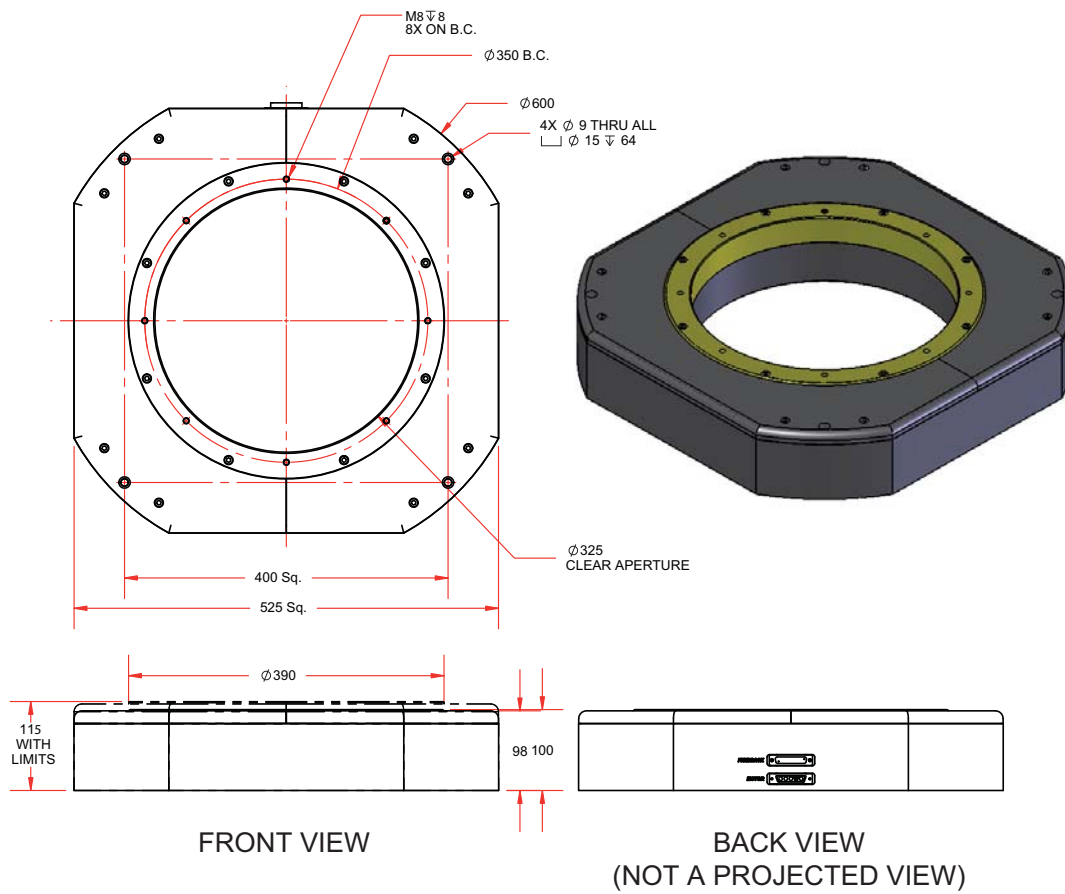

ANT95-R

Mechanical Bearing, Direct-Drive Rotary Stage

- High resolution (0.01 arc sec)
- High performance in large travels
- Outstanding error motion specifications
- Excellent in-position stability
- Multi-axis configurations
- High dynamic performance

The ANT95-R series direct-drive rotary stages are part of Aerotech's nano Motion Technology product family. Our rotary stages offer unprecedented in-position stability (0.005 arc sec) and sub 0.01 arc-sec incremental motion performance, and are available in two grades of accuracy. The ANT95-R series offers compatibility and easy integration with Aerotech's ANT linear stages. Together these stages provide accuracy, stability and small size performance capability for almost any nanomanufacturing or inspection application.

Mechanical Specifications		ANT95-20-R	ANT95-20-R-PLUS	ANT95-180-R	ANT95-180-R-PLUS	ANT95-360-R	ANT95-360-R-PLUS	
Rotation Angle		20°	20°	180°	180°	±360° Continuous	±360° Continuous	
Accuracy ⁽¹⁾		10 arc sec	3 arc sec	10 arc sec	3 arc sec	10 arc sec	3 arc sec	
Resolution		0.01 arc sec	0.01 arc sec	0.01 arc sec	0.01 arc sec	0.01 arc sec	0.01 arc sec	
Repeatability (Bi-Directional) ⁽⁴⁾		1.5 arc sec	1.5 arc sec	1.5 arc sec	1.5 arc sec	1.5 arc sec	1.5 arc sec	
Repeatability (Uni-Directional)		0.5 arc sec	0.5 arc sec	0.5 arc sec	0.5 arc sec	0.5 arc sec	0.5 arc sec	
Tilt Error Motion	Synchronous	NA	NA	NA	NA	10 arc sec	10 arc sec	
	Asynchronous	NA	NA	NA	NA	3 arc sec	3 arc sec	
Axial Error Motion ⁽¹⁾	Synchronous	NA	NA	NA	NA	2 µm	2 µm	
	Asynchronous	NA	NA	NA	NA	0.5 µm	0.5 µm	
Radial Error Motion ⁽¹⁾	Synchronous	NA	NA	NA	NA	3 µm	3 µm	
	Asynchronous	NA	NA	NA	NA	1 µm	1 µm	
Maximum Speed		20 rpm	20 rpm	20 rpm	20 rpm	200 rpm	200 rpm	
Maximum Acceleration		400 rad/s ²	400 rad/s ²	400 rad/s ²	400 rad/s ²	400 rad/s ²	400 rad/s ²	
In-Position Stability ⁽²⁾		0.005 arc sec	0.005 arc sec	0.005 arc sec	0.005 arc sec	0.005 arc sec	0.005 arc sec	
Aperture		11 mm (0.433 in)	11 mm (0.433 in)	11 mm (0.433 in)	11 mm (0.433 in)	11 mm (0.433 in)	11 mm (0.433 in)	
Maximum Torque (Continuous)		0.2 Nm	0.2 Nm	0.2 Nm	0.2 Nm	0.2 Nm	0.2 Nm	
Load Capacity ⁽³⁾	Axial	2.0 kg (4.4 lb)	2.0 kg (4.4 lb)	2.0 kg (4.4 lb)	2.0 kg (4.4 lb)	2.0 kg (4.4 lb)	2.0 kg (4.4 lb)	
	Radial	1.5 kg (3.3 lb)	1.5 kg (3.3 lb)	1.5 kg (3.3 lb)	1.5 kg (3.3 lb)	1.5 kg (3.3 lb)	1.5 kg (3.3 lb)	
	Moment	2 Nm	2 Nm	2 Nm	2 Nm	2 Nm	2 Nm	
Rotor Inertia (Unloaded)		0.00065 kg-m ²	0.00065 kg-m ²	0.00066 kg-m ²	0.00066 kg-m ²	0.00069 kg-m ²	0.00069 kg-m ²	
Stage Mass		1.2 kg (2.6 lb)	1.2 kg (2.6 lb)	1.2 kg (2.6 lb)	1.2 kg (2.6 lb)	1.2 kg (2.6 lb)	1.2 kg (2.6 lb)	
Material		Aluminum Body/Black Hardcoat Finish						
MTBF (Mean Time Between Failure)		30,000 Hours						

Notes:

1. Certified with each stage. Requires the use of an Aerotech controller.
2. In-Position Jitter listing is 3 sigma value.
3. Axis orientation for on-axis loading is listed.
- Specifications are per axis, measured 25 mm above the tabletop. Consult factory for multi-axis or non-standard applications.
- All error motion specifications are measured at 60 rpm.
- For high speed operation, customer payload must be balanced to G1.0 per ISO 1940.

ANT95-R

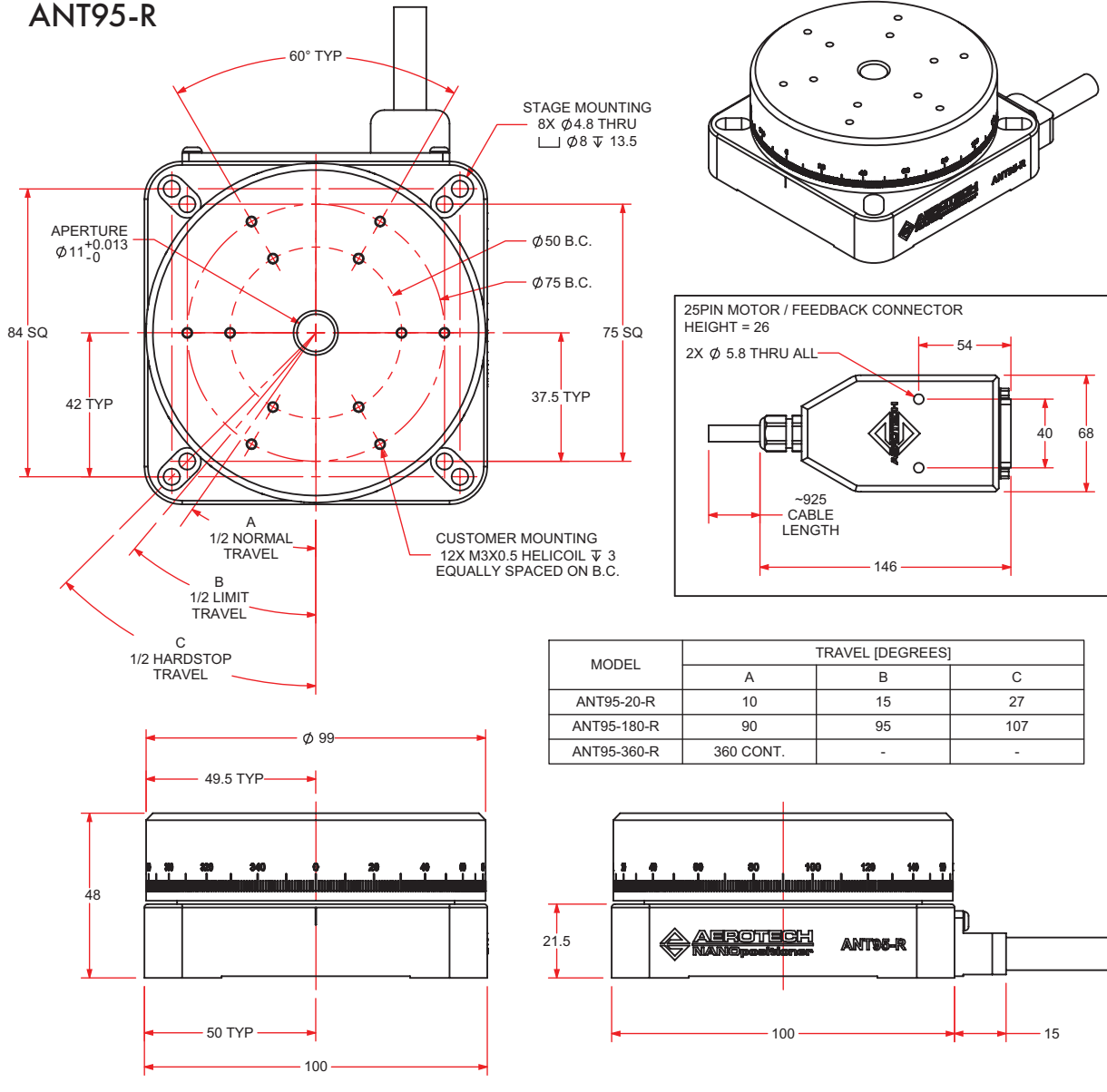

Unlike other rotary devices, the ANT95-R requires no periodic maintenance, assuring years of trouble-free operation.



ANT130-R

Mechanical Bearing, Direct-Drive Rotary Stage

- High resolution (0.01 arc sec)
- High performance in large travels
- Outstanding error motion specifications
- Excellent in-position stability
- Multi-axis configurations
- High dynamic performance

The ANT130-R series direct-drive rotary stages are part of Aerotech's nano Motion Technology product family. Our rotary stages offer unprecedented in-position stability (0.005 arc sec) and sub 0.01 arc-sec incremental motion performance, and are available in two grades of accuracy. ANT130-R stages operate in a 24/7 manufacturing environment. Unlike other rotary devices, the ANT130-R requires no periodic maintenance, assuring years of trouble-free operation.

Mechanical Specifications		ANT130-20-R	ANT130-20-R-PLUS	ANT130-180-R	ANT130-180-R-PLUS	ANT130-360-R	ANT130-360-R-PLUS
Rotation Angle		20°	20°	180°	180°	±360° Continuous	±360° Continuous
Accuracy ⁽¹⁾		10 arc sec	3 arc sec	10 arc sec	3 arc sec	10 arc sec	3 arc sec
Resolution		0.01 arc sec	0.01 arc sec	0.01 arc sec	0.01 arc sec	0.01 arc sec	0.01 arc sec
Repeatability (Bi-Directional) ⁽¹⁾		1.5 arc sec	1.5 arc sec	1.5 arc sec	1.5 arc sec	1.5 arc sec	1.5 arc sec
Repeatability (Uni-Directional)		0.5 arc sec	0.5 arc sec	0.5 arc sec	0.5 arc sec	0.5 arc sec	0.5 arc sec
Tilt Error Motion	Synchronous	NA	NA	NA	NA	10 arc sec	10 arc sec
	Asynchronous	NA	NA	NA	NA	3 arc sec	3 arc sec
Axial Error Motion ⁽¹⁾	Synchronous	NA	NA	NA	NA	2 µm	2 µm
	Asynchronous	NA	NA	NA	NA	0.5 µm	0.5 µm
Radial Error Motion ⁽¹⁾	Synchronous	NA	NA	NA	NA	3 µm	3 µm
	Asynchronous	NA	NA	NA	NA	1 µm	1 µm
Maximum Speed		20 rpm	20 rpm	20 rpm	20 rpm	200 rpm	200 rpm
Maximum Acceleration		400 rad/s ²	400 rad/s ²	400 rad/s ²	400 rad/s ²	400 rad/s ²	400 rad/s ²
In-Position Stability ⁽²⁾		0.005 arc sec	0.005 arc sec	0.005 arc sec	0.005 arc sec	0.005 arc sec	0.005 arc sec
Aperture		11 mm	11 mm	11 mm	11 mm	11 mm	11 mm
Maximum Torque (Continuous)		0.2 Nm	0.2 Nm	0.2 Nm	0.2 Nm	0.2 Nm	0.2 Nm
Load Capacity ⁽³⁾	Axial	3.0 kg (6.6 lb)	3.0 kg (6.6 lb)	3.0 kg (6.6 lb)	3.0 kg (6.6 lb)	3.0 kg (6.6 lb)	3.0 kg (6.6 lb)
	Radial	2.0 kg (4.4 lb)	2.0 kg (4.4 lb)	2.0 kg (4.4 lb)	2.0 kg (4.4 lb)	2.0 kg (4.4 lb)	2.0 kg (4.4 lb)
	Moment	3 Nm	3 Nm	3 Nm	3 Nm	3 Nm	3 Nm
Rotor Inertia (Unloaded)		0.001 kg-m ²	0.001 kg-m ²	0.001 kg-m ²	0.001 kg-m ²	0.0016 kg-m ²	0.0016 kg-m ²
Stage Mass		1.5 kg (3.3 lb)	1.5 kg (3.3 lb)	1.5 kg (3.3 lb)	1.5 kg (3.3 lb)	1.7 kg (3.74 lb)	1.7 kg (3.74 lb)
Material		Aluminum Body/Black Hardcoat Finish					
MTBF (Mean Time Between Failure)		30,000 Hours					

Notes:

1. Certified with each stage. Requires the use of an Aerotech controller.
 2. In-Position Jitter listing is 3 sigma value.
 3. Axis orientation for on-axis loading is listed.
- Specifications are per axis, measured 25 mm above the tabletop. Consult factory for multi-axis or non-standard applications.
 - All error motion specifications are measured at 60 rpm.
 - For high speed operation, customer payload must be balanced to G1.0 per ISO 1940.

ANT130-R

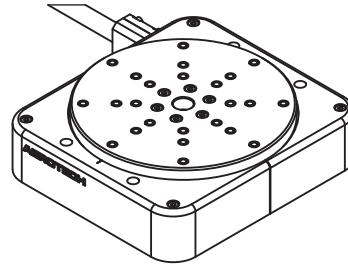
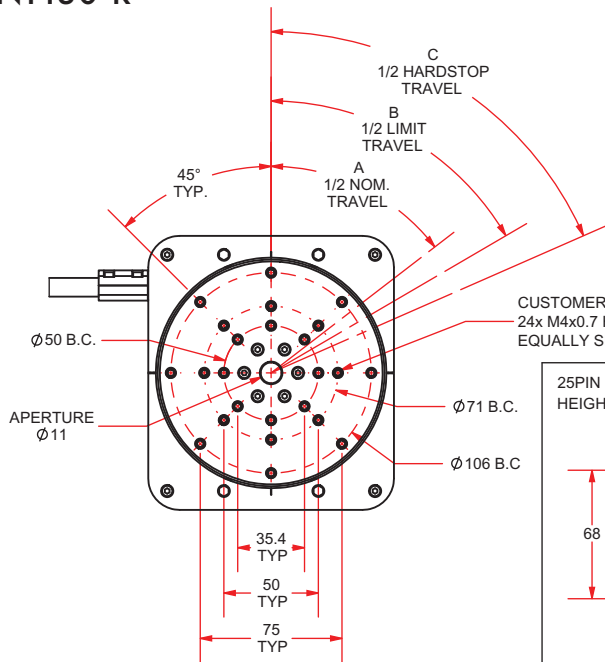

CUSTOMER MOUNTING
24x M4x0.7 HELICOIL ∇ 4.0
EQUALLY SPACED ON B.C.

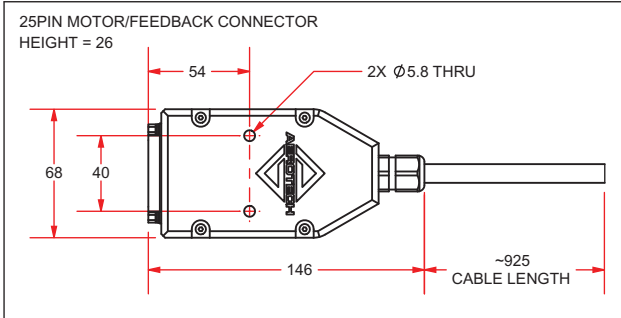

MODEL	TRAVEL (DEGREES)		
	A	B	C
ANT130-020-R	10	15	37
ANT130-180-R	90	95	117
ANT130-360-R	360 CONT.	-	-

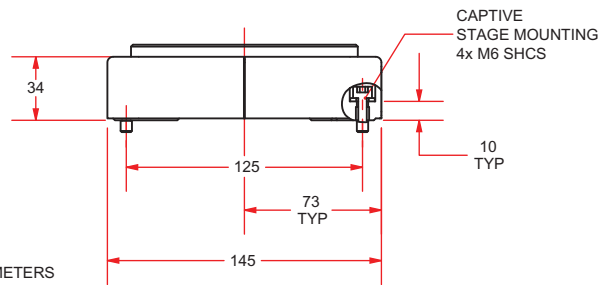
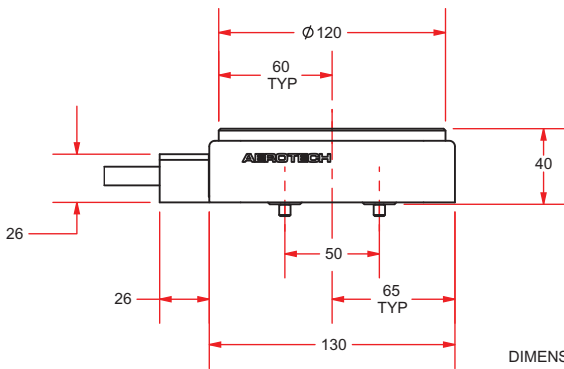

DIMENSIONS: MILLIMETERS



In addition to the high precision levels, these systems offer high dynamic performance and throughput ideal for disk drive manufacturing and test.

ASRT

Mechanical Bearing, Direct-Drive Rotary Stage

- IP66: Totally protected against dust and water jets from any direction
- Direct-drive motor provides rapid precision motion with no gear backlash
- Low-friction seal minimizes direction reversal hysteresis to allow small, precise positioning
- Continuous or limited travel
- Axial load capacity up to 175 kg
- Excellent accuracy and repeatability
- Three different aperture sizes: 30 mm, 80 mm, 130 mm
- Shaft aperture option allows for electrical, pneumatic or fluid feedthrough
- 100-200 rpm continuous rotation speed

ASRT sealed rotary stages provide precise angular positioning in hostile environments where dirt or liquids are present. The stage can operate in environments with dust or fluid jets. The ASRT also can be used where cutting fluids are present. Applications range from industrial machining automation to precision sensor positioning in hostile environments. The ASRT is effective for precise rotary motion in product environmental test and range tracking applications.

Mechanical Specifications		ASRT-185	ASRT-245	ASRT-300
Travel		360° Continuous		
Accuracy ⁽¹⁾ (-O)	Standard	20 arc sec		
	HALAR	2 arc sec		
Resolution (-O)		0.036 arc sec	0.027 arc sec	0.018 arc sec
Bi-Directional Repeatability ⁽¹⁾ (-O)		1 arc sec		
Accuracy ⁽¹⁾ (-M)	Standard	50 arc sec	45 arc sec	N/A
	HALAR	15 arc sec	15 arc sec	N/A
Resolution (-M)		0.63 arc sec	0.54 arc sec	N/A
Bi-Directional Repeatability ⁽¹⁾ (-M)		10 arc sec		
Tilt Error Motion		5 arc sec		
Maximum Speed		200 rpm	150 rpm	100 rpm
Maximum Acceleration		950 rad/s/s	900 rad/s/s	650 rad/s/s
Aperture		30 mm	80 mm	130 mm
Maximum Torque (Peak)		9.6 Nm	35.5 Nm	46.7 Nm
Maximum Torque (Continuous)		2.1 Nm	6.6 Nm	9.7 Nm
Load Capacity	Axial	30 kg	140 kg	175 kg
	Radial	25 kg	125 kg	150 kg
	Moment	175 Nm	425 Nm	500 Nm
Rotor Inertia (Unloaded)	Base Model	0.0096 kg-m ²	0.026 kg-m ²	0.066 kg-m ²
	Aperture Opt.	0.013 kg-m ²	0.039 kg-m ²	0.079 kg-m ²
Stage Mass	Base Model	10.3 kg	18.8 kg	25.0 kg
	Aperture Opt.	12.6 kg	21.9 kg	29.0 kg
Material		Polymer-Painted Aluminum/Aluminum Hardcoat		
MTBF (Mean Time Between Failure) ⁽²⁾		10,000 Hours		

Note:

1. Certified with each stage.
2. Application dependent. Dry environments between 0° and 70°C up to 10,000 hours.
3. Long-term exposure to temperature cycles and wet environments will require periodic maintenance.

ASRT-185

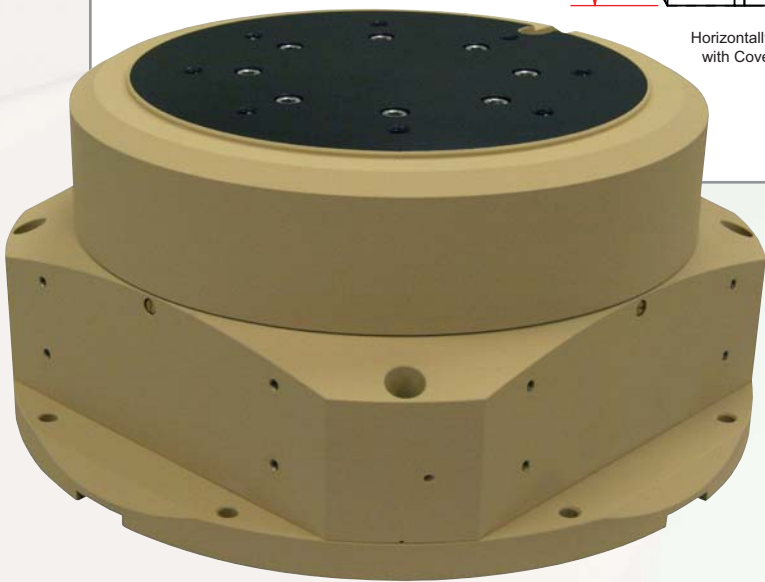
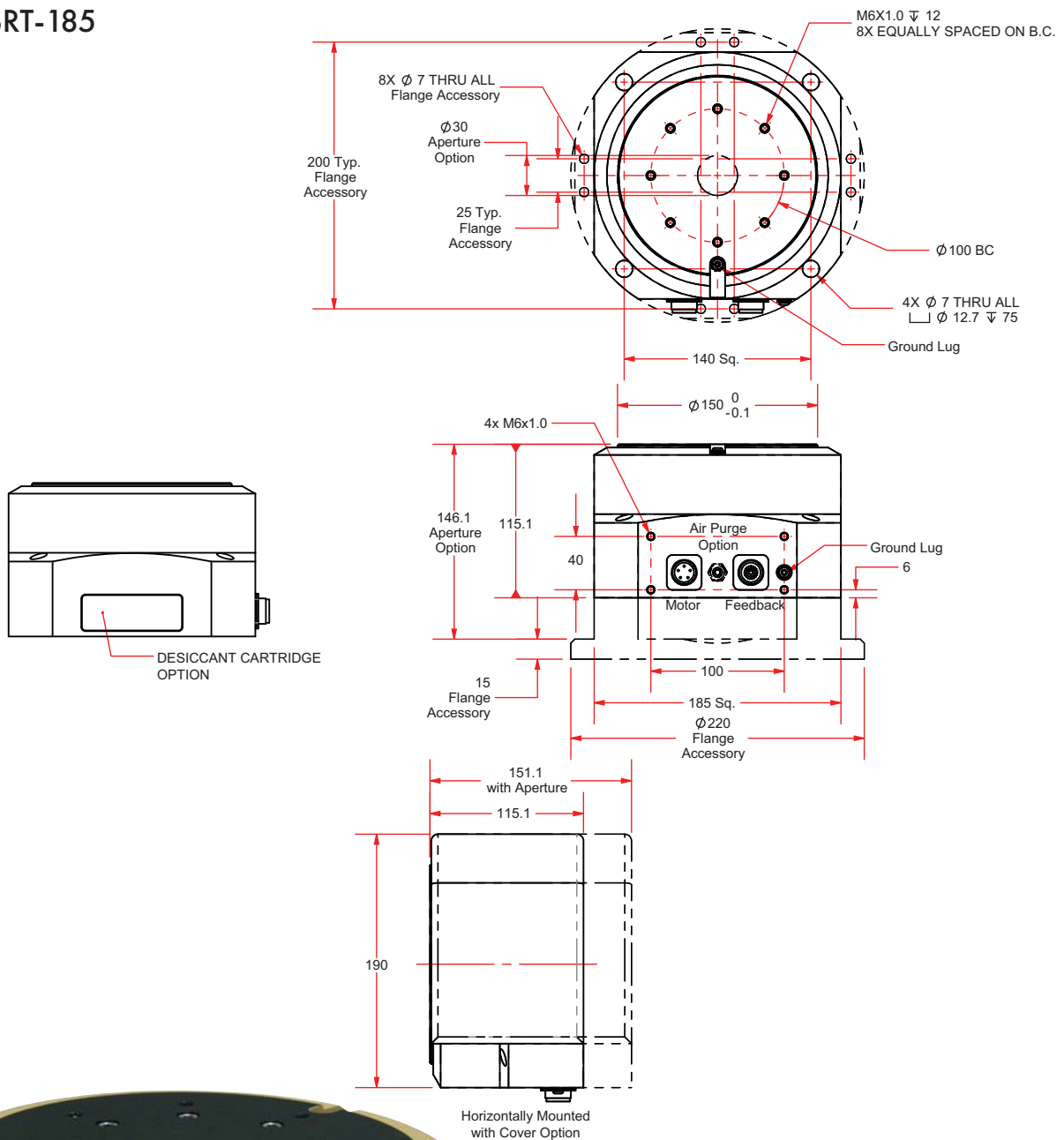

The ASRT is effective for precise rotary motion in product environmental test and range tracking applications.

ARMS

Mechanical Bearing, Direct-Drive Rotary Stage

- Designed for highly accurate motion generation
- Velocity stability of 0.0001% over 360°
- Position resolution to 0.02 arc sec
- Payloads to 230 kg
- Integrated slip rings and fluid rotary unions
- Direct-drive brushless motor options for high speed or high torque

Aerotech's ARMS series direct-drive rotary motion simulators provide superior angular rates, accelerations, and positioning for the testing of inertial components and systems such as MEMS, gyroscopes, inertial measurement units, avionics and accelerometers. When coupled with Aerotech's advanced controls, resolution can be as fine as 0.02 arc seconds, with accuracy to ± 2.5 arc seconds and repeatability to ± 0.5 arc seconds. The ARMS has rate resolution down to 0.002 deg/s and rate stability to 0.0001%. Low inertia and zero backlash make the ARMS the ideal solution for applications requiring frequent directional changes.

ARMS Series		ARMS-150-12	ARMS-150-37	ARMS-200-56	ARMS-200-80	ARMS-260-100	ARMS-260-146
Width		146 mm		196 mm		260 mm	
Height ⁽¹⁾		183 mm	246 mm	224 mm	249 mm	229 mm	250 mm
Aperture ⁽²⁾		8 mm				25 mm	
Total Travel		$\pm 360^\circ$ Continuous					
Motor		S-130-39-A	S-130-102-A	S-180-69-A	S-180-94-A	S-240-63-A	S-240-83-A
Continuous Current, Stall	A _{pk}	3.8	3.1	5.1	4.9	5.9	5.8
	A _{rms}	2.7	2.2	3.6	3.5	4.2	4.1
Bus Voltage		Up to 320 VDC					
Peak Torque		11.7 N-m	37.4 N-m	55.6 N-m	80.0 N-m	100 N-m	146 N-m
Continuous Torque		2.8 N-m	9.2 N-m	13.7 N-m	19.9 N-m	24.9 N-m	36.5 N-m
Resolution		0.04-4 arc sec		0.03-3 arc sec		0.02-2 arc sec	
Fundamental Encoder Resolution		16,200 lines/rev		23,600 lines/rev		32,400 lines/rev	
Accuracy ⁽³⁾		± 2.5 arc sec					
Repeatability		± 0.5 arc sec					
Max Load ⁽⁴⁾	Axial	30 kg		140 kg		230 kg	
Max Load ⁽⁴⁾	Moment	175 N-m		425 N-m		650 N-m	
Wobble		± 1 arc sec					
Maximum Rate ⁽⁵⁾		1500°/s					
Minimum Rate ⁽⁶⁾		0.002°/s				0.001°/s	
Rate Resolution ⁽⁶⁾		0.002°/s				0.001°/s	
Rate Stability ⁽⁶⁾	Over 360°	0.0001%					
	Over 10°	0.005%					
	Over 1°	0.05%					
Peak Acceleration ⁽⁷⁾		$> 20,000^\circ/\text{s}^2$					
Inertia (unloaded) ⁽⁷⁾		6,600 kg-mm ²	9,700 kg-mm ²	33,600 kg-mm ²	39,800 kg-mm ²	115,200 kg-mm ²	139,000 kg-mm ²
Total Mass ⁽⁷⁾		9 kg	15 kg	22 kg	26 kg	39 kg	44 kg
Servo Bandwidth ⁽⁸⁾		> 70 Hz (-3 dB)					
Material		Aluminum					
Stage Finish		Black Anodize					
Tabletop Finish		Hard Coating (62 Rockwell Hardness)					

Notes:

1. Height may vary with certain slip ring and rotary union options. See product dimensional drawings for more details.
2. Aperture not available with all slip ring and rotary union options. See ordering information for more details.
3. Certified with each stage. Requires the use of an Aerotech controller.
4. Maximum loads are mutually exclusive.
5. Maximum rate is based on stage capability. Actual rate may depend on encoder resolution, load, amplifier bus voltage and motor. See the S-series rotary motor for more information.
6. Minimum rate, rate resolution and rate accuracy are based on stage capability. Actual rate, resolution and accuracy may depend on encoder resolution.
7. Peak acceleration, inertia and total mass based on unloaded stage with standard diameter tabletop.
8. Servo bandwidth is based on unloaded stage with standard diameter tabletop. Actual bandwidth may depend on mass and inertia of stage payload.

ARMS-260

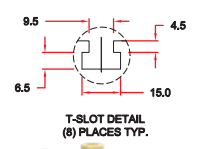
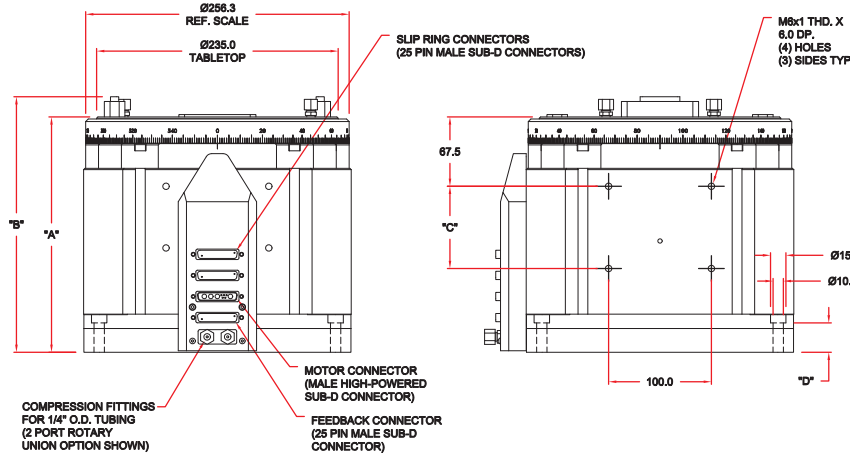
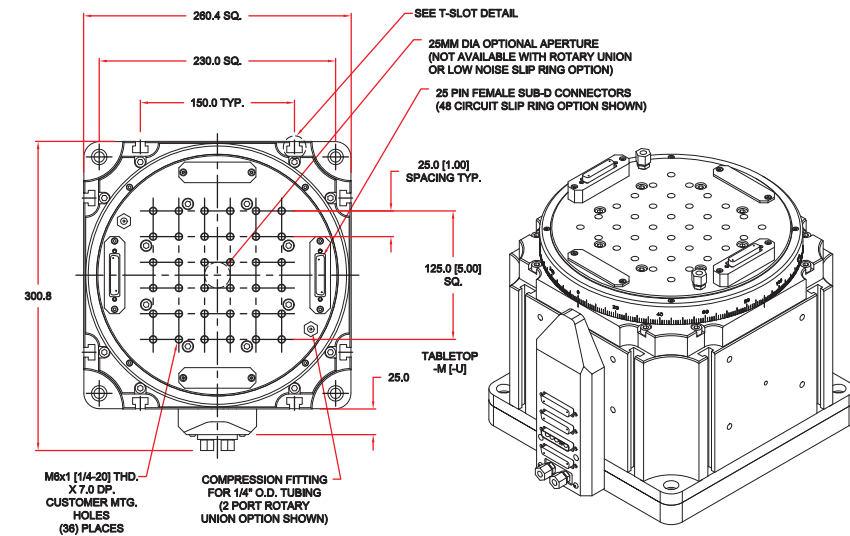

DIMENSIONS - MILLIMETERS				
BASIC MODEL	"A"	"B"	"C"	"D"
ARMS-260-100-SRNG24(24LN)	229.0	248.6	80.0	28.6
ARMS-260-100-SRNG48(48LN)	229.0	248.6	80.0	28.6
ARMS-260-100-SRNG72(70LN)	279.0	298.6	80.0	78.6
ARMS-260-100-SRNG96(90LN)	329.0	348.6	80.0	128.6
ARMS-260-146-SRNG24(24LN)	250.0	269.6	100.0	28.6
ARMS-260-146-SRNG48(48LN)	250.0	269.6	100.0	28.6
ARMS-260-146-SRNG72(70LN)	279.0	298.6	100.0	57.6
ARMS-260-146-SRNG96(90LN)	329.0	348.6	100.0	100.6



Low inertia and zero backlash make the ARMS the ideal solution for applications requiring frequent directional changes.

AGR

Mechanical Bearing, Gear-Drive Rotary Stage

- Enhanced speed and load capacity
- Large aperture addresses a wide range of applications
- Continuous 360° rotary positioning
- Direct encoder options available
- Operation over a wide temperature range

AGR series motorized rotary stages provide significant improvements in speed, load capacity and long-term positioning performance over previous generations of worm-gear-drive stages. AGR series stages address a wide range of applications for general purpose positioning in laboratory and industrial uses. The addition of a larger clear aperture is a key enhancement over previous generations of worm-gear-driven stages.

Mechanical Specifications		AGR50	AGR75	AGR100	AGR150	AGR200
Travel		360° (Limited Travel Versions Available)				
Accuracy⁽¹⁾	Standard	180 arc sec		120 arc sec		
	Direct Encoder	20 arc sec				
Repeatability (Uni-Directional)⁽¹⁾	Standard	10 arc sec				
	Direct Encoder	5 arc sec				
Repeatability (Bi-Directional)⁽¹⁾	Standard	45 arc sec				
	Direct Encoder	8 arc sec				
Tilt Error Motion		10 arc sec				
Axial Error Motion		5 µm				
Radial Error Motion		10 µm				
Gear Ratio		51:1	67:1	85:1	117:1	126:1
Maximum Speed⁽²⁾	BM/BMS	180°/s				120°/s
	SM	60°/s		40°/s		
Maximum Acceleration⁽³⁾		720°/s ²				480°/s ²
Aperture	mm	50 mm	75 mm	100 mm	150 mm	200 mm
Load Capacity	Axial	40 kg	100 kg	200 kg	300 kg	425 kg
	Radial	20 kg	50 kg	100 kg	125 kg	200 kg
	Moment	See Moment Load Curves				
Maximum Torque Load to Stage Shaft		2.5 N·m	3.5 N·m	12 N·m	20 N·m	80 N·m
Rotor Inertia (Unloaded)		0.00052 kg·m ²	0.0013 kg·m ²	0.0035 kg·m ²	0.011 kg·m ²	0.076 kg·m ²
Stage Mass (No Motor)	Standard	1.9 kg	2.4 kg	4.5 kg	6.1 kg	18.6 kg
	Direct Encoder	2.5 kg	3.1 kg	5.6 kg	7.6 kg	21.7 kg
Material		Aluminum				

Note:

1. Certified with each stage.
2. Maximum speed is load dependent. Contact an Aerotech Application Engineer if imbalanced loads are present.
3. Unloaded acceleration.
4. On-axis loading is listed.
5. Specifications are for single-axis systems measured 25 mm above the tabletop. Performance of multi-axis systems is payload and workpoint dependent. Consult factory for multi-axis or non-standard applications.

AGR-100

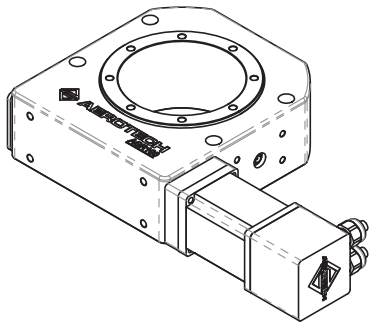

MOTOR	LENGTH "A"
BM75	132.3
BM75-BRAKE	209.5
BMS60	132.3
BMS60-BRAKE	209.5
50SMB2-HM	84.3

OPTION	HEIGHT "B"
DEFAULT	65
SEAL	78
ENCODER	81
SEAL + ENCODER	94

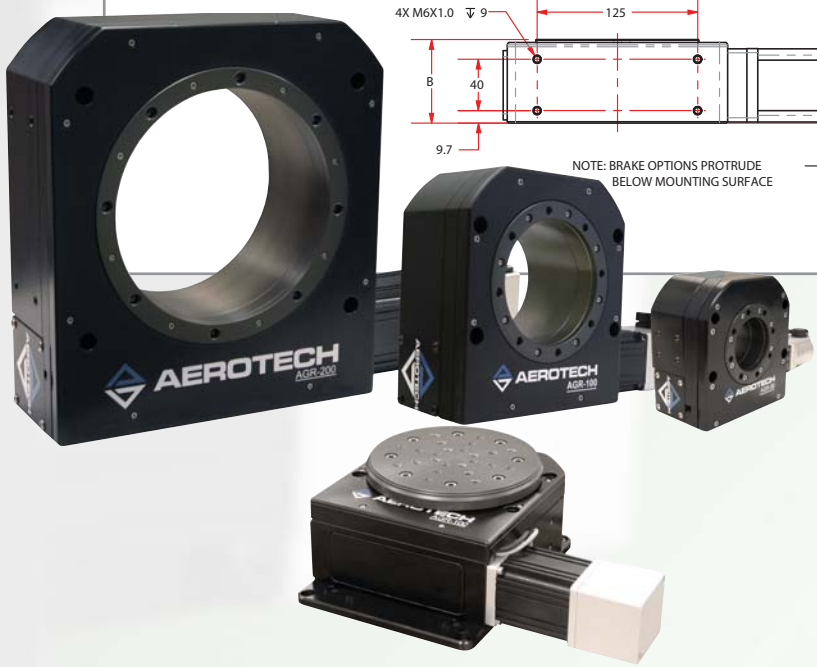
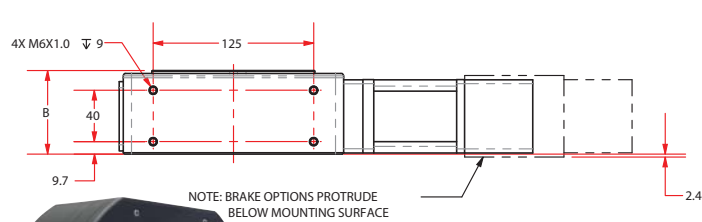
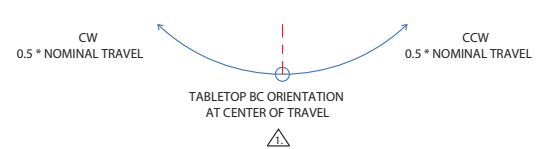
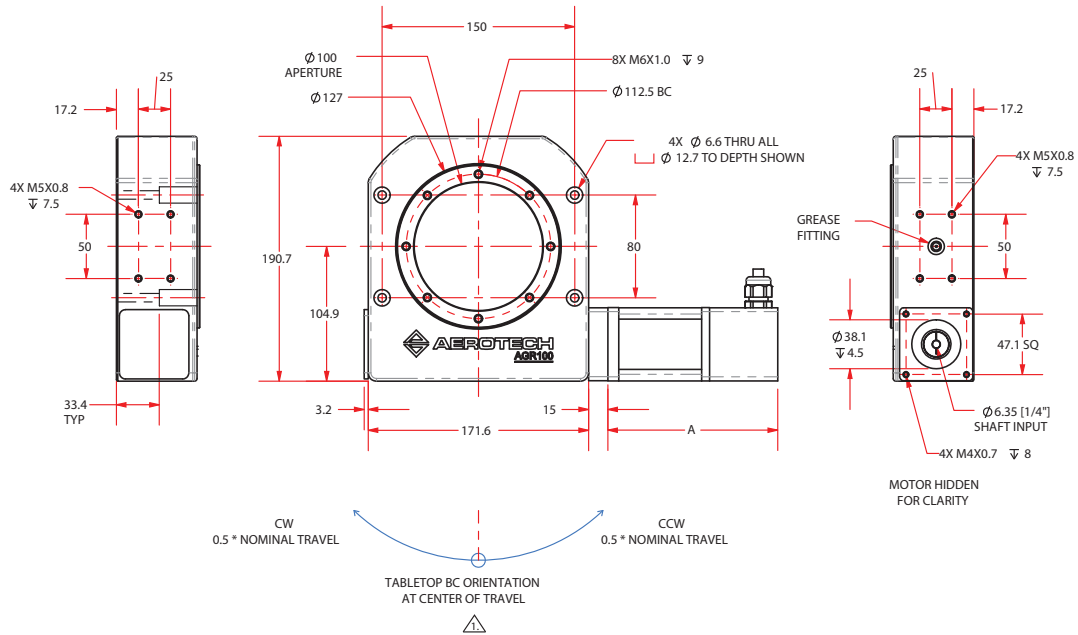

The addition of a larger clear aperture allows the AGR series to address applications requiring a through-hole or accommodations to mount an optic.

Advanced System Controls

GSE: Ground Support Equipment

- Save time and money with reconfigurable ground support equipment
- Windows®-based motion controllers provide simple, user-friendly software in LabVIEW®, .NET, C, C#, AeroBasic™
- Position Synchronized Output trigger for laser, eddy current or ultrasonic sensor control
- Easily configured for brushless, brush and stepper motors
- Reads resolver, inductosyn, incremental and absolute encoder signals
- Capture all motion performance during testing for quality control
- Loop transmission frequency response testing built-in

Use the libraries and example code to develop your own front-end and applications with .NET, C#, C and LabVIEW®.

- Easy setup with calculators and autotune routine
- Use state-of-the-art IDE for developing your motion program
- Second-to-none diagnostics toolkit
- Conditional 2D error plotting

Automation 3200



- Up to 32 tasks
- PC-based
- RS-274 G-code
- Advanced features for demanding applications
- 1 to 32 axes of coordinated motion
- Scanner control for marking
- Tightly integrated laser functionality
- Retrofit package
- Analog and digital I/O

Ensemble



- Up to 4 tasks
- Stand-alone 1- to 10-axis controller
- Versatile, cost-effective, coordinated motion
- PWM or linear drives (10-150 A peak)

Integrated Development Environment

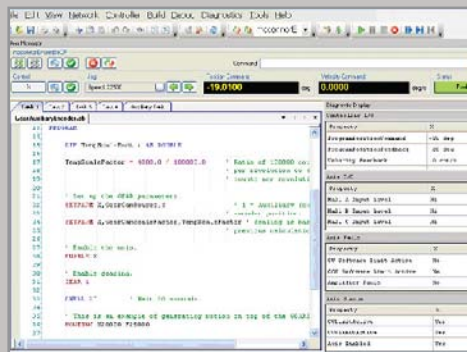

Programming Interface

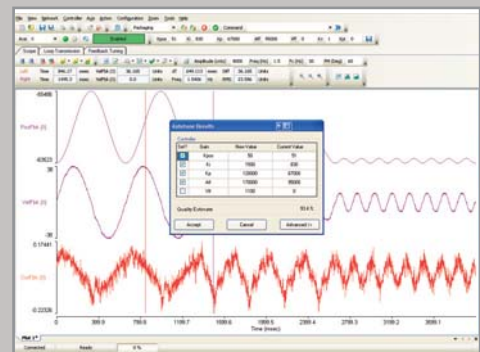

Autotune

Linear and Rotary Servo and Torque Motors



Interfaces

- Ethernet/IP™
- Modbus®/TCP
- DeviceNET
- Ethernet TCP/IP
- USB
- RS-232
- GPIB



Accessories

- Linear amps
- ESTOP
- Rack-mount configuration
- Rack-mount PCs



- Brushless, brush or stepper motors
- Desktop or panel mount
- .NET, C++ or LabVIEW®
- GPIB, Ethernet, USB

Soloist



- Elegant, economical, single-axis controller
- Stand-alone
- PWM or linear drives (10-150 A peak)
- .NET, C#, LabVIEW®
- Ethernet, USB

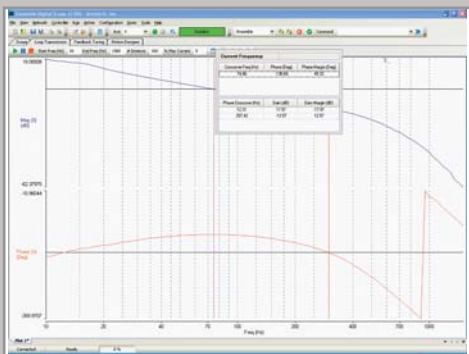

Loop Transmission

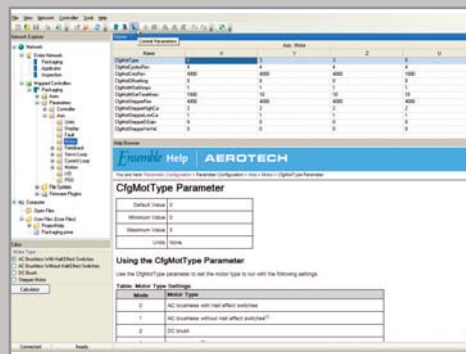

Parameter Editor

Aerotech at a Glance



Corporate Headquarters • Pittsburgh, PA • USA



Aerotech UK



Aerotech Germany



Aerotech Japan



Aerotech China

High Volume Manufacturing

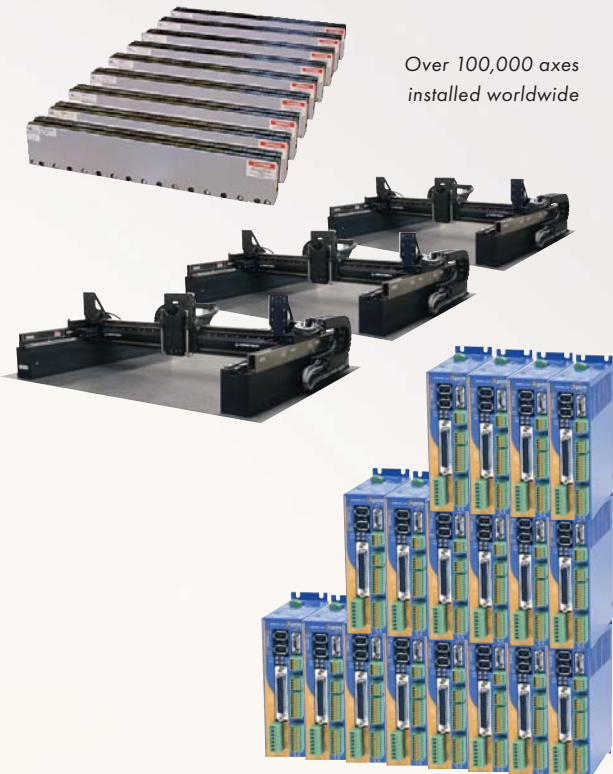

Over 100,000 axes
installed worldwide

Worldwide Service and Support



Worldwide startup
service and on-site
training



Fully equipped on-site
training facilities



Technically Superior Components

Highest performance brushless linear and rotary motors



AGR rotary stage

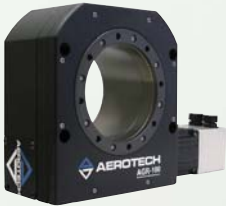

PRO series linear-motor stage



Ndrive



A3200



Npaq

Award-winning Automation 3200 1-32 axis motion, vision, PLC, robotics and I/O platform

High Performance Sub-Assemblies

XYAB subsystem for high dynamic accuracy positioning in laser drilling and micromachining applications



LaserTurn 5 high-speed cylindrical laser cutting system



Highest throughput linear motor Cartesian gantry systems

Best-in-Class Subsystems



Highly integrated motion subsystems with machine base, display and packaged electronics



Custom-engineered vacuum- and cleanroom-compatible systems



Production-proven, large format air-bearing systems for flat panel and semiconductor applications

Comprehensive Technical Support Services



Custom software application support

3D models to facilitate faster and more accurate system layout

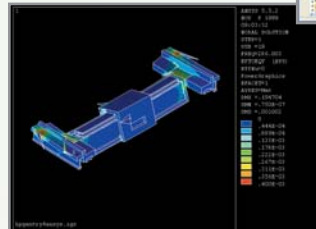
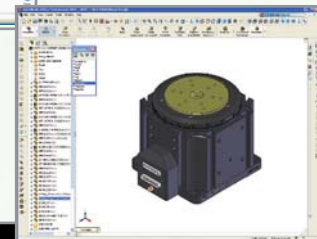

Advanced analytical techniques for optimization of system geometry

Aerotech Rotary Calibrator (ARC)

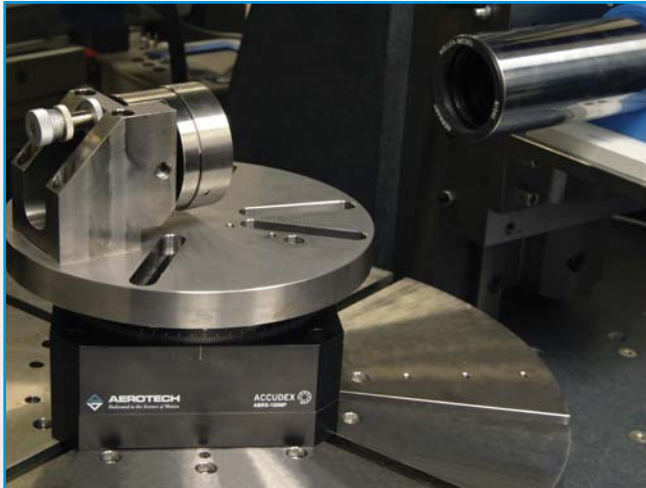

The Aerotech Rotary Calibrator (ARC) sets a new industry standard of performance for angle and rotary table calibrations. At the heart of the Calibrator is a large rotary air-bearing axis with nanometer-level error motion performance. This high-accuracy air-bearing master axis is constructed of steel to closely match the CTE of the surrounding granite structure. The air-bearing acts as the master angle generator to generate angles as small as 0.015 arc-seconds to over 360° (continuous rotation).

The Calibrator is equipped with a high-resolution, high-accuracy electronic autocollimator for measurement feedback on optical surfaces. The entire instrument is built on



a precision granite machine structure that is isolated from the machine base and floor through passive air isolation. A custom enclosure isolates the system from air turbulence, high-frequency thermal fluctuations and ambient light. System electronics are housed in a separate enclosure from the instrument to isolate any electrical noise and heat from the instrument. Custom calibration software provides the operator with easy control of the angular step, test procedure (such as circle closure) and plot/report generation.

1. Angular measurement uncertainty analysis performed according to ANSI/NCSL Z540-2-1997: Guide to the Expression of Uncertainty in Measurement while calibration of a rotary table over 360° with 10° steps using a modified circle closure technique. The temperature of the lab was controlled to 20°C ±0.25°C.

Specifications

- Master-axis accuracy:
<0.15 arc-seconds (<727 nano-radians)
- Minimum incremental step (min. angle):
0.015 arc-seconds (73 nano-radians)
- Electronic system resolution:
0.0069 arc-seconds (34 nano-radians)
- Angular measurement uncertainty:
<0.2 arc-seconds expanded uncertainty, k=2
(<970 nano-radians, k=2)¹.

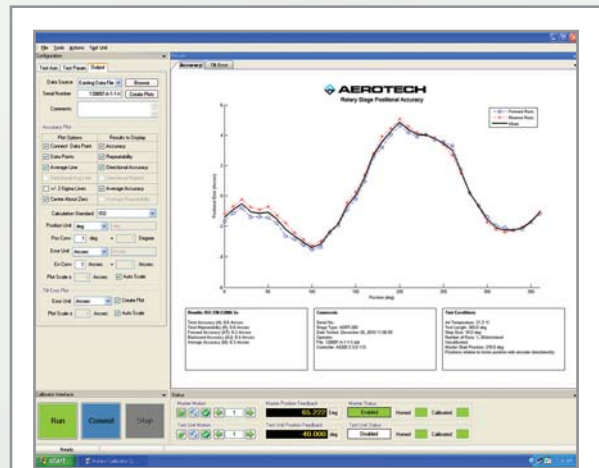

- Customized software for automated test execution and report generation
- Built-in control and plot utilities

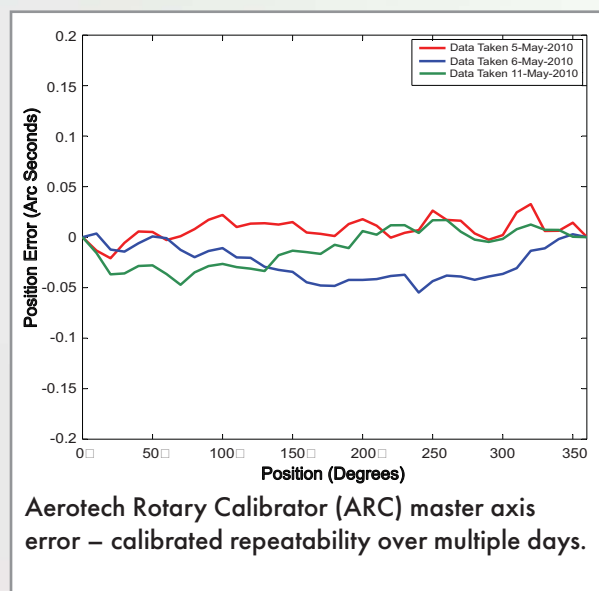

Aerotech Rotary Calibrator (ARC) master axis error – calibrated repeatability over multiple days.

Awards and Recognition



2011 Control Engineering
Engineers' Choice Award –
ANT130-XY



Design News 2010
Golden Mousetrap Winner –
ANT130-XY



Design News
2009 Golden Mousetrap Finalist
Product – LaserTurn® 1,
AGS15000, ANT95-XY

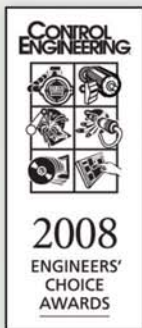

2008 Control
Engineering Engineers'
Choice Award –
LaserTurn® 1



Semiconductor
International 2008 Editors'
Choice Best Product –
Ensemble™



Design News
2008 Golden Mousetrap Finalist
Product –
Nmark™ SSaM



Semiconductor
International 2007
Editors' Choice Best Product –
WaferMax T™



EuroAsia IC 2006
Industry Award –
WaferMax Z™



Product Design and
Development
2002 Top 50 Product –
Automation 3200



Design News 2002
Best Product Nominee –
Automation 3200



Aandrijftechniek
2002 Award –
FiberMax®



Lightwave NFOEC 2002
Attendees' Choice Award –
FiberMax®



Lightwave OFC 2001
Attendees' Choice Award
– FiberAlign® 130



Machine Design Excellence in
Manufacturing Technology –
Slides/Ways 1998 and 2000

Capabilities in Other Markets

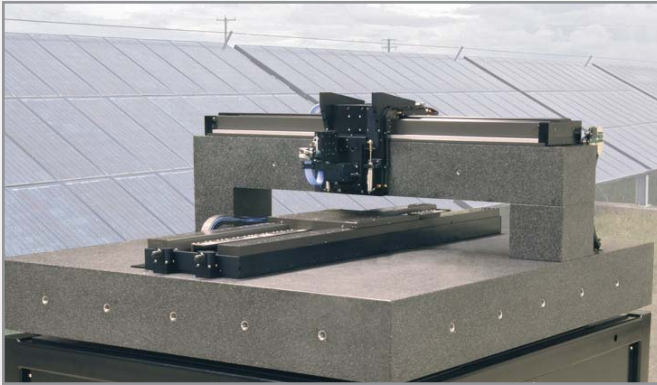

Photovoltaic, Fuel Cell and Alternative Energy

Extensive application experience and a broad array of motion products make Aerotech the perfect partner for your photovoltaic (solar cell), fuel cell and other alternative energy manufacturing and testing platforms. Our worldwide operation has engineered and manufactured a multitude of motion platforms for these markets and we continue to provide innovative solutions.

General Automation

Since 1970 Aerotech has been a manufacturer of top-quality automation products. The breadth of the company's product line, including automated nanopositioners, planar air-bearing systems, high-speed gantries, linear and rotary and lift stages, brushless linear and rotary servomotors and drives, single- and multi-axis motion controllers, goniometers and gimbals/optical mounts, makes Aerotech unique among motion control manufacturers. Aerotech is *Dedicated to the Science of Motion.*

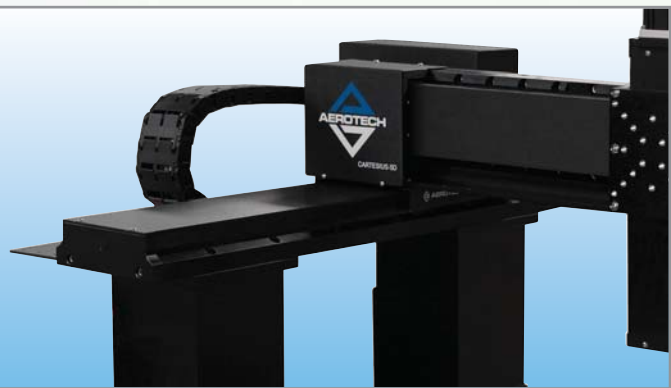

Control Systems

Aerotech motion controllers, motors and drives are utilized in our own positioning systems and by end users and OEMs worldwide. From our Automation 3200 software-based motion controller that can control up to 32 axes, to the Soloist™ single-axis servo controller, to the Ensemble™ multi-axis stand-alone motion controller, Aerotech provides a variety of options to suit your application.

Laser Processing

Aerotech has extensive experience in providing motion components and subsystems for laser processes such as cutting, welding, marking, etching and micromachining. These processes are the key to advancing technology in markets such as photovoltaic manufacturing, aerospace and medical device manufacturing.

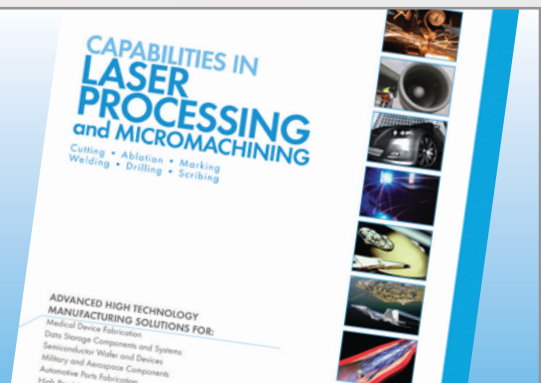

Medical Device Manufacturing and Life Sciences

Aerotech manufactures high-performance motion systems and components for medical and life sciences applications including stent cutting, medical laser welding systems for cardiac pacemakers and catheters, IOL and contact lens manufacturing, DNA sequencing, blood sequencing, haptic mills and drills, x-ray machines, magnetic resonance scanners and CAT scanners. We can customize a medical laser welding system for any need.

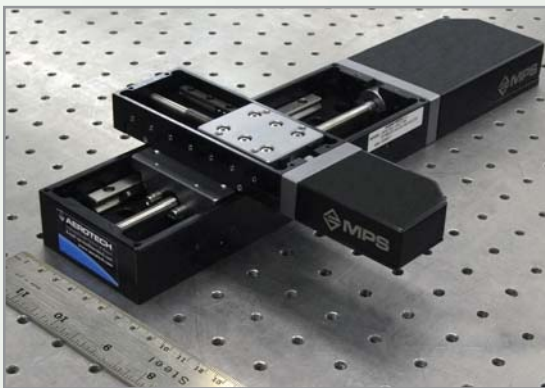
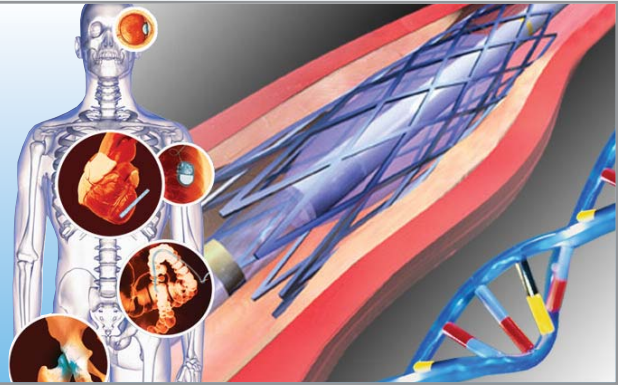

Government and Educational Research and Development

The breadth of Aerotech's product line offers solutions for the wide-ranging requirements of academic and government R&D. The fiberoptic line of positioning stages provides the accuracy required not only for photonics experiments, but also for micro- and nanomachining workstations. Aerotech's multi-axis rotary positioners and gimbals offer the high precision needed for defense, satellite and space science research. Unique applications call for unique solutions, and Aerotech can provide custom-engineered systems to meet your needs.

Electronics Manufacturing and Assembly

Speed, accuracy and reliability are the key requirements for pick-and-place machines, stencil cutting machines, printed circuit board assembly and other electronic manufacturing and assembly equipment. Since 1970 Aerotech has exceeded the most stringent criteria used to judge electronic manufacturing and assembly equipment, and we continue to raise the standard with our advanced motion technologies by addressing industry-specific challenges in pick-and-place machines, stencil cutting machines and printed circuit board assembly systems.

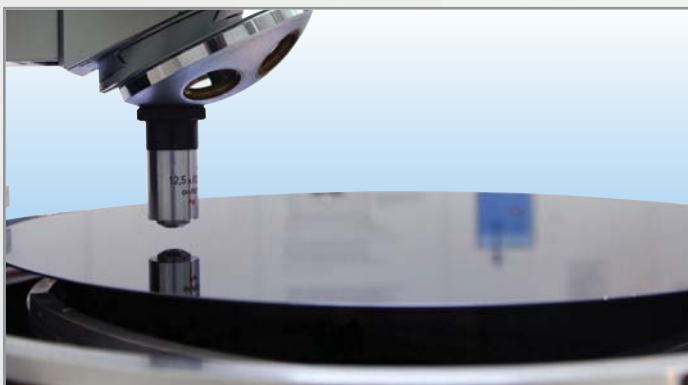

Test and Inspection

Aerotech is involved in test and inspection across a wide array of industries with applications including CMMs, ultrasonic, eddy current, x-ray, optical and electronic. All of these applications rely on Aerotech products' unmatched precision, accuracy and durability. Optical inspection solutions range from high-end linear-motor-driven models packaged with all control elements in an optimized machine base, to modular systems specifically designed for cost-sensitive applications.



Dedicated to the Science of Motion

Aerotech's Worldwide Sales and Service Locations

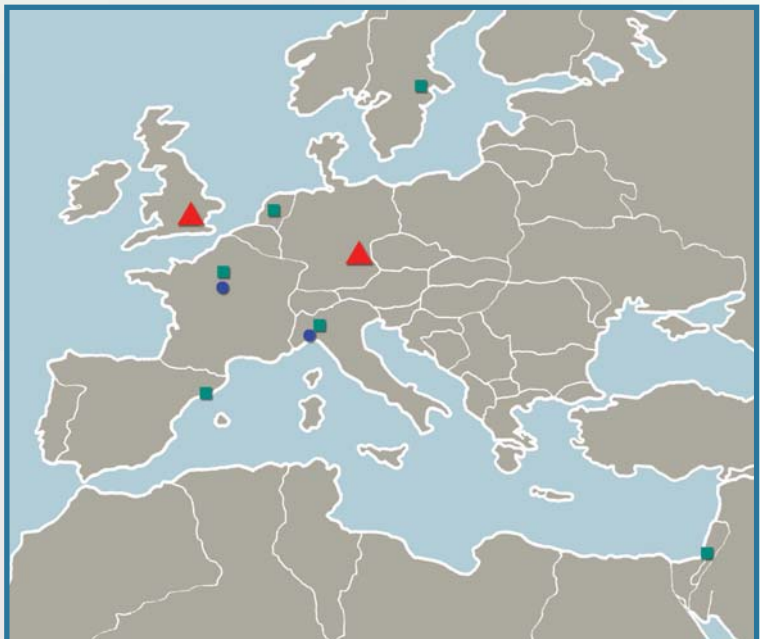
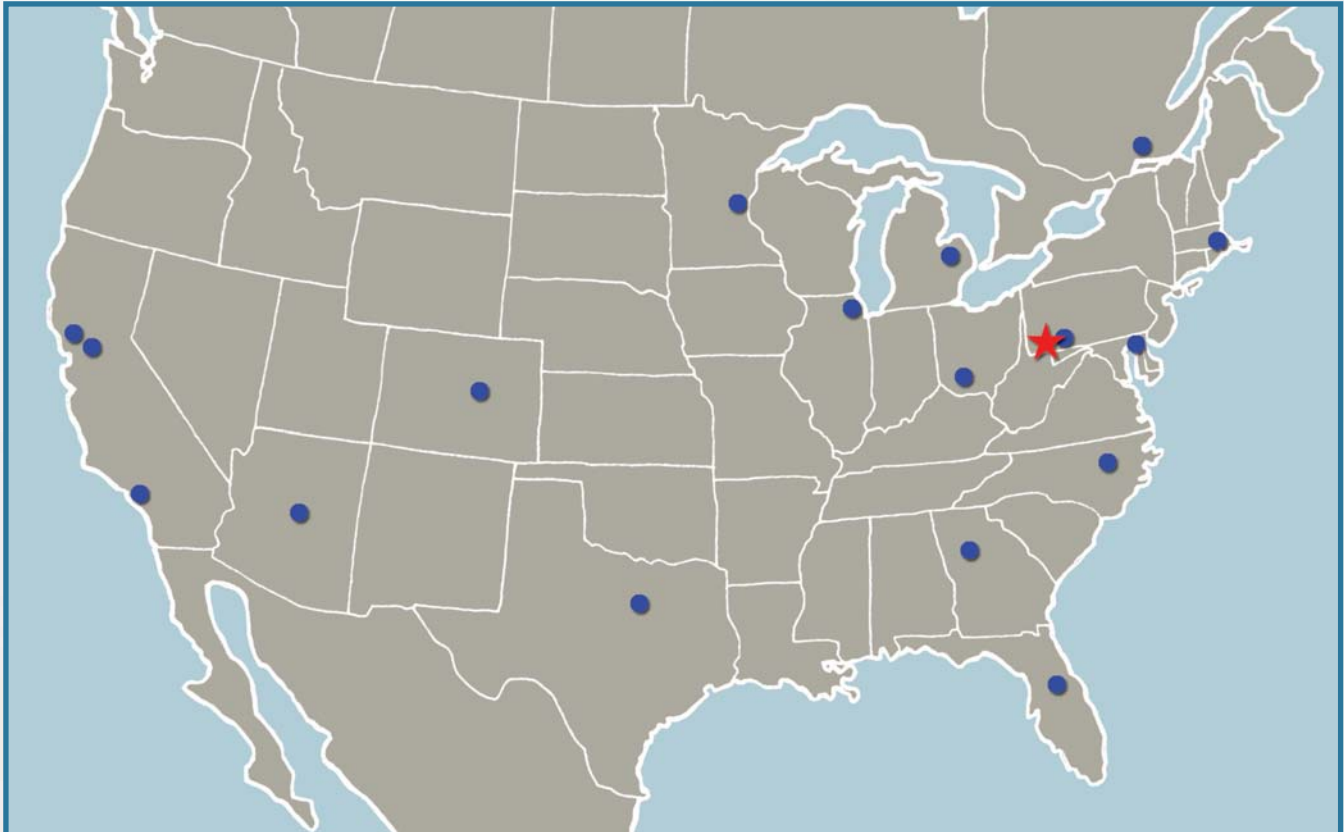

★ - Aerotech Headquarters ● - Direct Field Sales Office ▲ - Aerotech Subsidiary ■ - Representative

www.aerotech.com

