

AGC Series

Gear-Driven Goniometers

$\pm 45^\circ$ rotary positioning with unobstructed 360° view of customer load

Stackable design with common rotation point

Precision worm gear drive for outstanding accuracy and repeatability

Direct encoder option

Horizontal or vertical mounting orientation

High load capacity

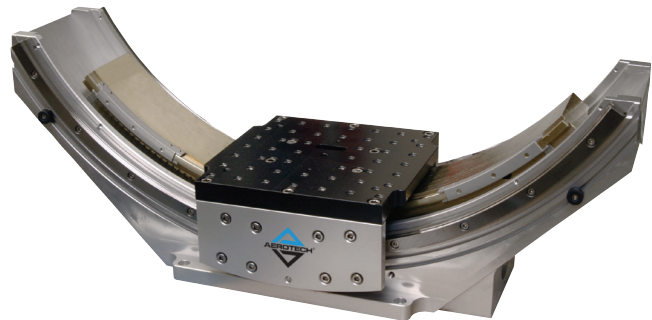

AGC motorized mechanical goniometers are used in applications where 90 degrees of angular travel is needed with the payload at the center of rotation, or where two axes of rotation are needed about a common point. AGC goniometers are designed to be mounted to standard optical tables, as well as standard Aerotech rotary stages, to provide roll, pitch, and yaw about a common 3-axis intersection. This flexible stage series is ideal for optical alignment, payload tip/tilt, beam steering, sensor calibration, laser applications, automated manufacturing and/or testing, and multi-axis diffractometer systems.

Construction Features

The sizes within the AGC family are designed to be mounted on one another to form a three-axis rotary system with all three axes of rotation sharing a common intersection point. This allows compact pitch/roll/yaw systems to be created easily from a standard stage platform and without special adapter plates or mating fixtures. The drive mechanism for AGC stages is a precision gear and matched worm that are preloaded to reduce backlash. All AGC stages include optical limit switches and hard stops to define a ± 45 degree range of travel.

Innovative feedback technology yields stable performance and negligible performance drift over the life of the stage. This is in stark contrast to inferior designs that must be continually adjusted to compensate for worm wear. All stage tabletops feature hardcoated aluminum, with stainless-steel Heli-Coil® inserts to prevent thread wear.

Flexible Options

Options include flexible motor selections as well as a direct encoder mounted along the stage travel to offer outstanding repeatability and to minimize hysteresis and backlash. Vacuum-compatible versions, for use in pressures as low as 10⁻⁶ torr, are also available.

Motor and Drives

Standard AGC stage configurations feature Aerotech's brushless servomotors. A full range of matching drives and controls are available for a complete single-source solution.

AGC SPECIFICATIONS

Mechanical Specifications		AGC85	AGC160	AGC245
Travel Range		±45°		
Accuracy ⁽¹⁾		±12 arc sec		
Resolution (Minimum Incremental Motion)		3 arc sec		
Repeatability (Bi-Directional) ⁽¹⁾		±10 arc sec		
Repeatability (Uni-Directional) ⁽¹⁾		±5 arc sec		
Tilt Error Motion		40 arc sec		
Gear Ratio		152:1	192:1	288:1
Maximum Speed		30°/s		
Nominal Radius of Rotation		125 mm	200 mm	300 mm
Distance from Tabletop to Rotation Point		85 mm	160 mm	245 mm
Maximum Torque (Continuous)		18 N-m	24 N-m	44 N-m
Load Capacity ⁽²⁾	Axial	20 kg	30 kg	50 kg
	Moment	20 N-m	30 N-m	50 N-m
Stage Mass		5.6 kg	12.5 kg	24.3 kg
Material		Aluminum Body/Clear Anodize Finish		
MTBF (Mean Time Between Failure)		5000 Hours		

Notes:

1. Certified with each stage. Requires direct encoder feedback with calibration option and is tested with Aerotech controller.
2. On-axis loading is listed.
3. Specifications are for single-axis systems measured at the center of rotation. Performance of multi-axis systems is payload and workpoint dependent. Consult factory for multi-axis or non-standard applications.
4. Load Center of Mass not to exceed bounding volume of 160 mm in diameter by 80 mm above pivot point.

Electrical Specifications			AGC85	AGC160	AGC245
Drive System			Worm-Gear Assembly		
Feedback			Rotary Encoder on Drive Motor and Noncontact Direct Encoder		
Maximum Bus Voltage			320 VDC		
Limit Switches			5 V, Normally Closed		
Home Switch			Near Limit		
Motor Line Count (cnts/rev)	Analog		1000	1000	1000
	Digital		2500	2500	5000
Direct Encoder Radius (mm)			116.7	195.7	294.2
Electrical Resolution	Motor Encoder	Analog - Fundamental (arc sec)	8.5263	6.7500	4.500
		Digital (arc sec)	0.8526	0.6750	0.2250
	Direct Encoder	Analog - Fundamental (arc sec)	35.3496	21.0797	14.0221
		Digital x50 (arc sec)	0.1767	0.1054	0.0701

Recommended Controller		AGC85	AGC160	AGC245
Multi-Axis	A3200/Npaq	Ndrive CP20	Ndrive CP20	Ndrive CP20
	Ensemble	Ensemble CP20	Ensemble CP20	Ensemble CP20
Single Axis	Soloist	Soloist CP20	Soloist CP20	Soloist CP20

AGC85 (Feedback Option Shown)

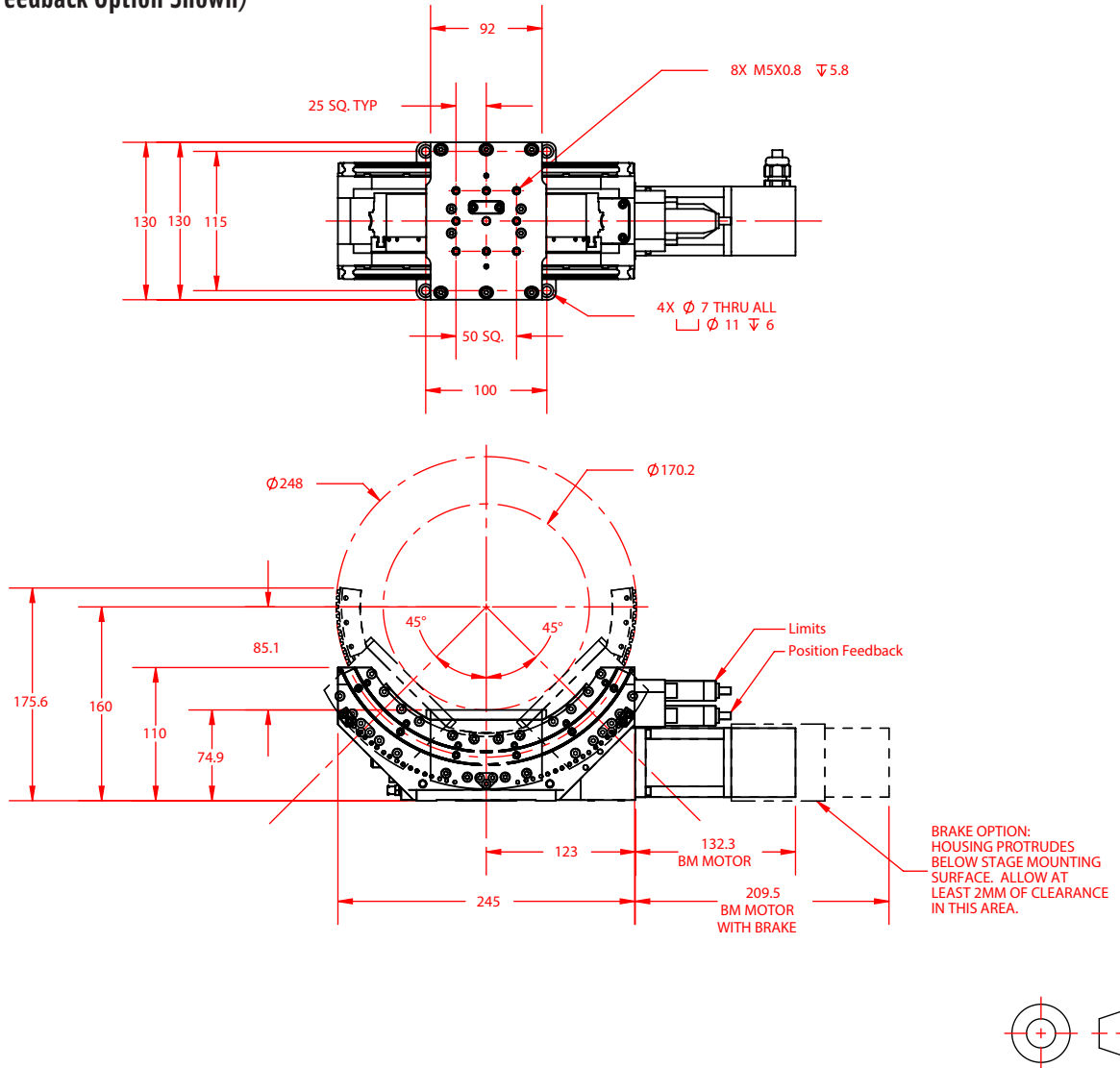

AGC160 (Feedback Option Shown)

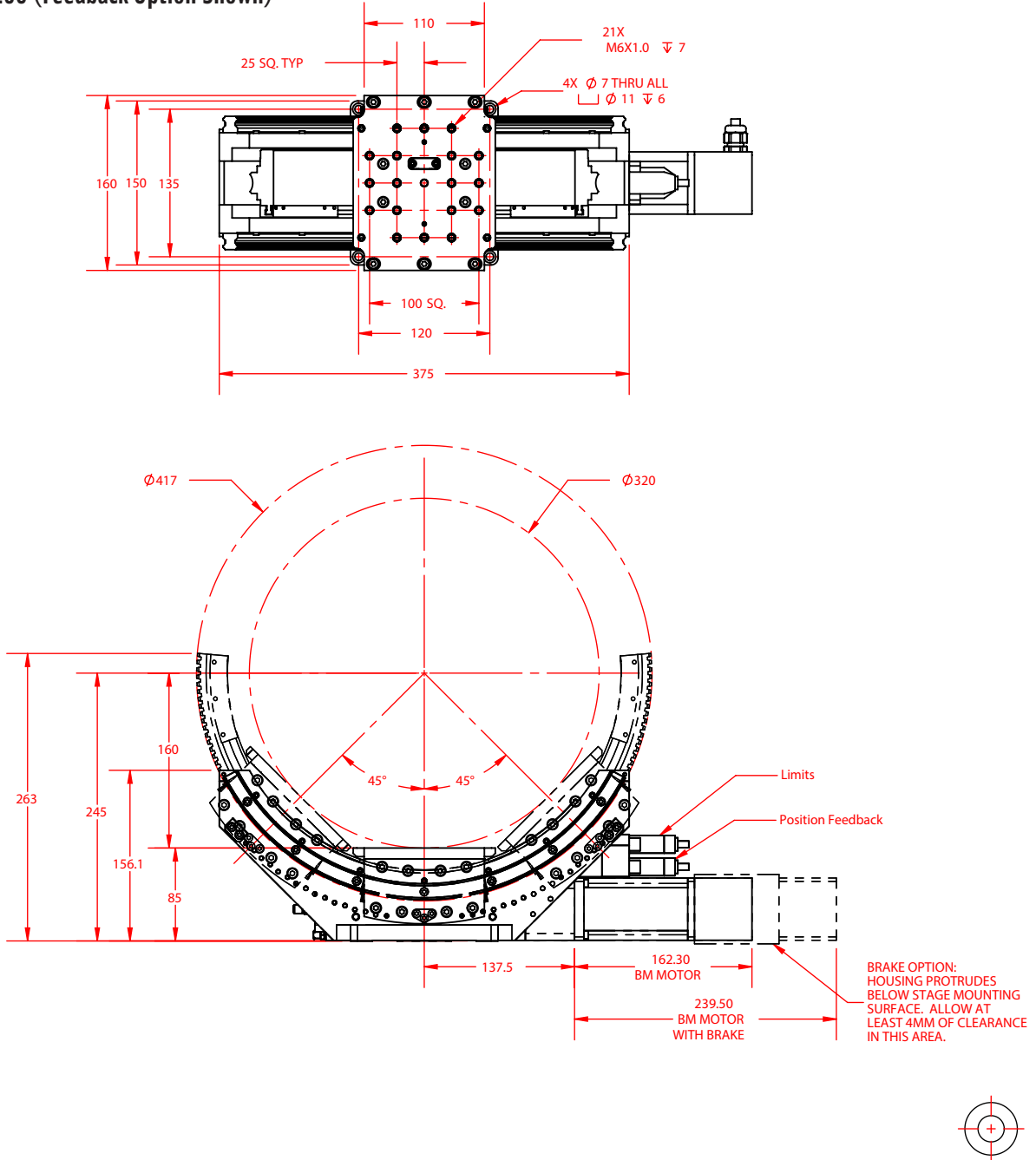

AGC245 (Feedback Option Shown)

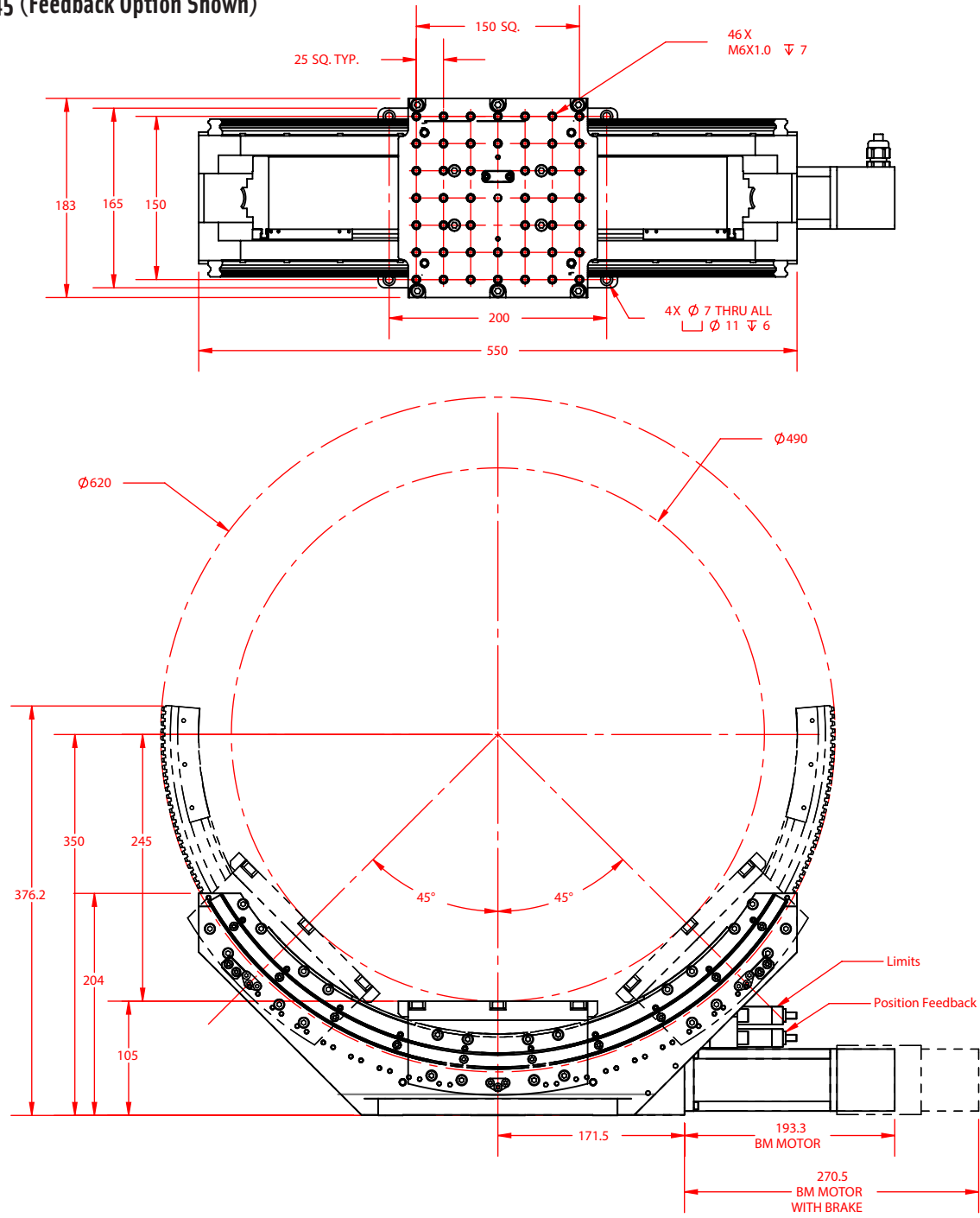

AGC160-AGC85 Stack (Feedback Option Shown)

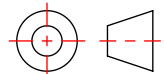
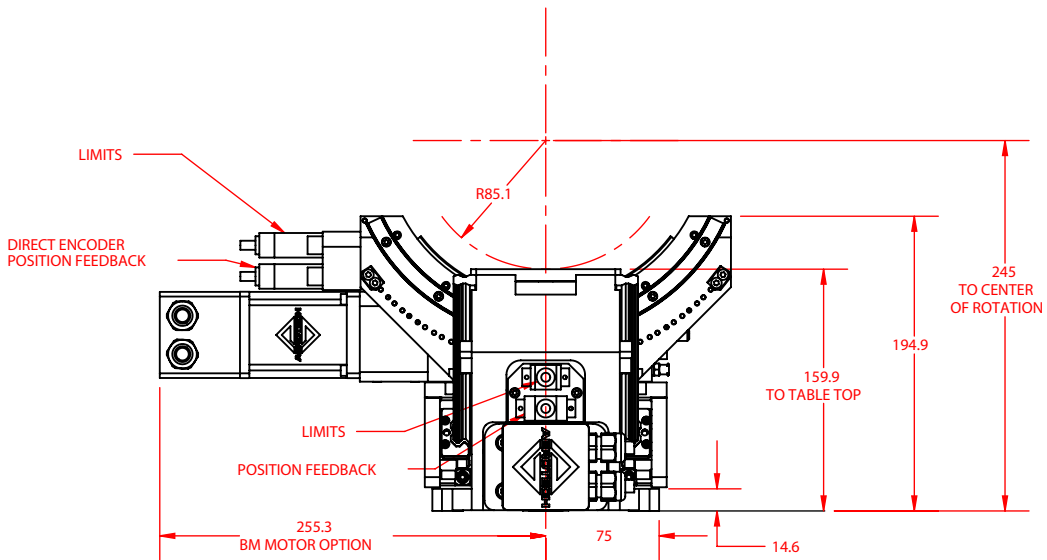
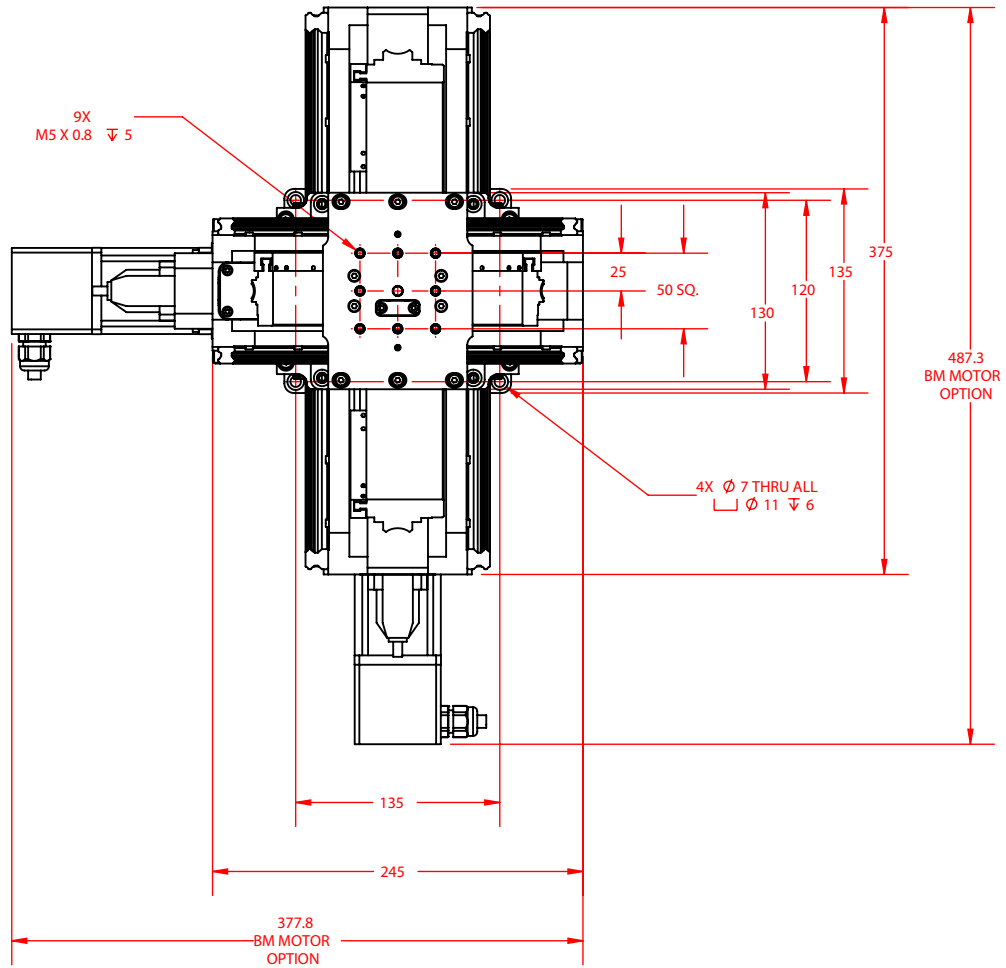

AGC245-AGC160 Stack (Feedback Option Shown)

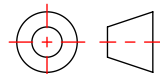
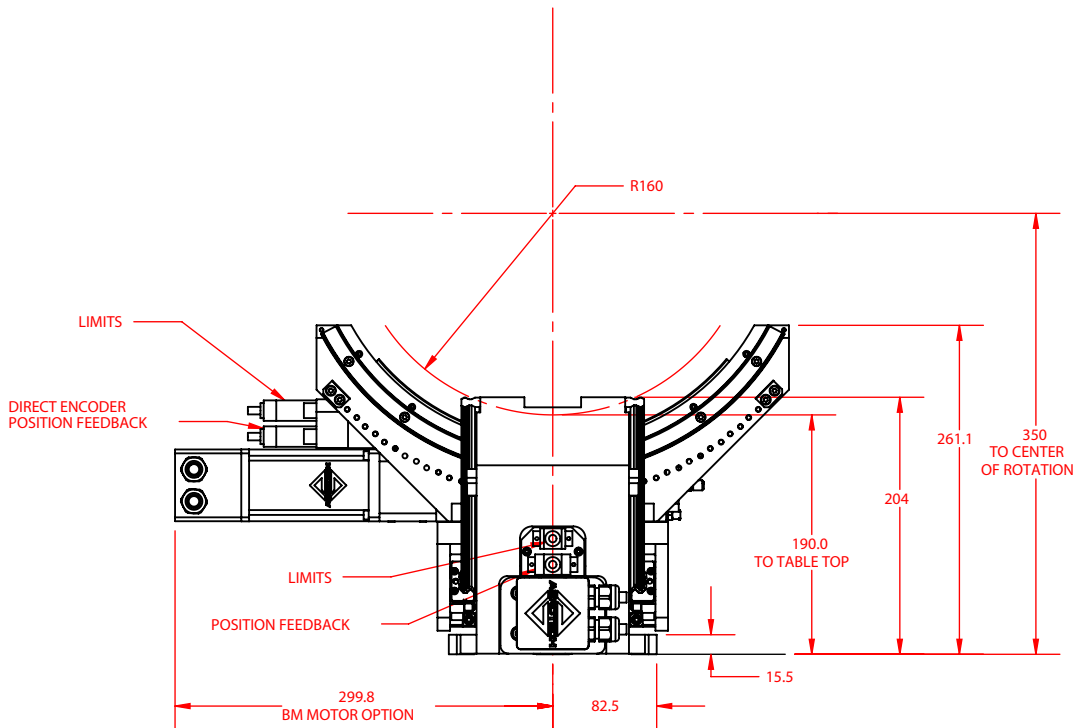
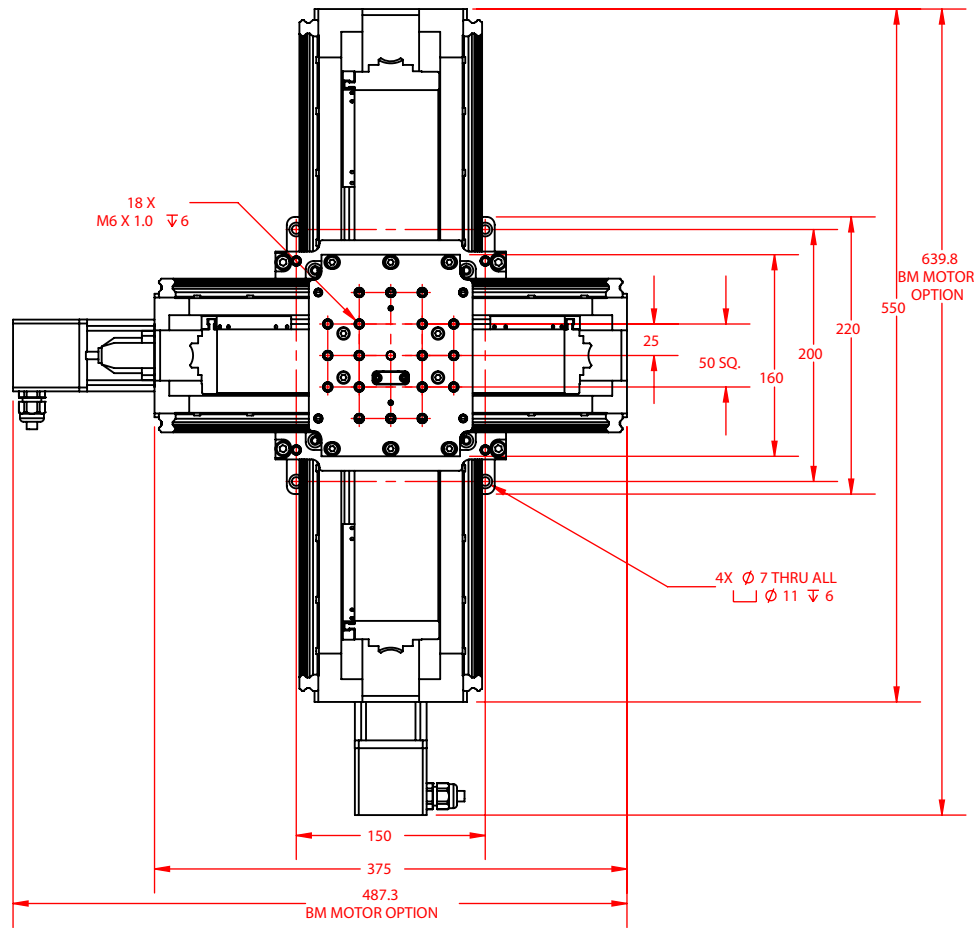

AGC Series ORDERING INFORMATION

AGC Series Gear-Driven Goniometer

AGC85	Gear-driven goniometer, 85 mm radius of curvature
AGC160	Gear-driven goniometer, 160 mm radius of curvature
AGC245	Gear-driven goniometer, 245 mm radius of curvature

Travel (Required)

-TR010	Limited travel, ± 5 degrees
-TR015	Limited travel, ± 7.5 degrees
-TR020	Limited travel, ± 10 degrees
-TR025	Limited travel, ± 12.5 degrees
-TR030	Limited travel, ± 15 degrees
-TR035	Limited travel, ± 17.5 degrees
-TR040	Limited travel, ± 20 degrees
-TR045	Limited travel, ± 22.5 degrees
-TR050	Limited travel, ± 25 degrees
-TR060	Limited travel, ± 30 degrees
-TR070	Limited travel, ± 35 degrees
-TR080	Limited travel, ± 40 degrees
-TR090	Limited travel, ± 45 degrees

Motor (Optional)

-M1	Brushless servomotor with digital encoder; AGC85 (BM75 with 2500-line TTL encoder); AGC160 (BM130 with 2500-line TTL encoder); AGC245 (BM200 with 5000-line TTL encoder)
-M2	Brushless servomotor with digital encoder and brake; AGC85 (BM75 with 2500-line TTL encoder); AGC160 (BM130 with 2500-line TTL encoder); AGC245 (BM200 with 5000-line TTL encoder)
-M3	Brushless servomotor, 1000-line 1 Vpp encoder; AGC85 (BM75); AGC160 (BM130); AGC245 (BM200)
-M4	Brushless servomotor, 1000-line 1 Vpp encoder and brake; AGC85 (BM75); AGC160 (BM130); AGC245 (BM200)

Motor Orientation (Required)

-2	Bottom cable exit, optional orientation
-3	Left-side cable exit, standard orientation
-4	Top cable exit, optional orientation
-5	Right-side cable exit, optional orientation

Direct Rotary Feedback (Optional)

-E1	Incremental encoder, 1 Vpp
-E2	Incremental encoder, digital TTL output, x50 multiplication

Note: Using AGC stages with dual feedback loops will necessitate that the drive motor is outfitted with an amplified sine encoder and appropriate encoder interpolation (MXH, MXU or MXR).

Integration (Required)

Aerotech offers both standard and custom integration services to help you get your system fully operational as quickly as possible. The following standard integration options are available for this system. Please consult Aerotech if you are unsure what level of integration is required, or if you desire custom integration support with your system.

-TAS	<p>Integration - Test as system</p> <p>Testing, integration, and documentation of a group of components as a complete system that will be used together (ex: drive, controller, and stage). This includes parameter file generation, system tuning, and documentation of the system configuration.</p>
-TAC	<p>Integration - Test as components</p> <p>Testing and integration of individual items as discrete components that ship together. This is typically used for spare parts, replacement parts, or items that will not be used together. These components may or may not be part of a larger system.</p>