

MPS-GR Series

Miniature Gear-Driven Rotary Stage

Low profile and compact with aperture

Precision worm-gear drive

DC servo or stepper motor

Continuous 360° rotary positioning

Graduated tabletop

High vacuum capable

Optional lens mount adapter

Compact multi-axis configurations with linear and other MPS series stages



The MPS50GR and MPS75GR miniature rotary stages provide accurate positioning for both the confines of the laboratory and in manufacturing environments.

The MPS50GR and MPS75GR rotary stages provide accurate positioning performance in a low profile and compact footprint. They are perfect for the confines and requirements of the laboratory and are also applicable for use in manufacturing environments. MPS-GR stages are ideal for optics, measurement, alignment and other demanding applications.

Construction Features

The MPS-GR stages incorporate a precision worm-gear drive mechanism and bearing components for highly accurate positioning performance over the lifetime of the product. They are available with DC servo or stepper motors. The DC servomotors for both stages are equipped with a square-wave rotary encoder. The MPS50GR has a 20 mm aperture and the MPS75GR has a 30 mm aperture. The MPS75GR includes a manual adjustment knob.



The MPS-GR series includes a graduated tabletop.

Vacuum and Mounting Options

Both stages are available with optional vacuum preparation to 10^{-6} torr including a vacuum-rated connector. An optional breadboard mounting plate provides direct mounting to both English and metric breadboards. Also available is an aperture Lens Mount Option (LMO) for easy mounting of standard lenses over the stage aperture.

The MPS50GR and MPS75GR are members of the MPS (Miniature Positioning Stage) family of linear, rotary, goniometer and vertical lift stages. Two or more stages can easily be mounted together in numerous combinations using standardized mounting patterns with adapter plates and brackets.

MPS-GR Series SPECIFICATIONS

Mechanical Specifications		MPS50GR	MPS75GR
Travel		360° Continuous	
Accuracy ⁽¹⁾	Uncalibrated	250 arc sec	200 arc sec
	Calibrated	80 arc sec	
Resolution (Minimum Incremental Motion)	DC Servomotor (-M1)	2 arc sec	1 arc sec
	Stepper Motor (-M2)	2 arc sec	1 arc sec
Unidirectional Repeatability ⁽¹⁾	DC Servomotor (-M1)	8 arc sec	6 arc sec
	Stepper Motor (-M2)	20 arc sec	10 arc sec
Tilt Error Motion		40 arc sec	
Worm Gear Ratio		80:1	100:1
Maximum Speed	DC Servomotor (-M1)	23 deg/s	180 deg/s
	Stepper Motor (-M2)	4.5 deg/s	100 deg/s
Aperture		20 mm	30 mm
Maximum Torque (Continuous)		0.4 N-m	0.6 N-m
Load Capacity	Axial	4 kg	12 kg
	Radial	1 kg	5 kg
	Moment	0.25 N-m	1.5 N-m
Rotor Inertia (Unloaded)		0.000031 kg-m ²	0.000141 kg-m ²
Stage Mass		0.8 kg	1.7 kg
Material		Anodized Aluminum Body	

Notes:

1. With Aerotech controllers.
2. Payload specifications are single-axis system.
3. Excessive duty cycle may impact stage accuracy.
4. Specifications are for single-axis systems measured 25 mm above the tabletop. Performance of multi-axis systems is payload and workpoint dependent. Consult factory for multi-axis or non-standard applications.

Electrical Specifications	MPS50GR DC Servomotor (-M1)	MPS50GR Stepper Motor (-M2)	MPS75GR DC Servomotor (-M1)	MPS75GR Stepper Motor (-M2)
Drive System	DC Brush Servomotor with 14:1 Gearbox	24 VDC Bipolar Stepper Motor with 43:1 Gearbox	DC Brush Servomotor	24 VDC Bipolar Stepper Motor
Feedback	512 Lines/Rev Rotary Encoder	N/A	10,000 Lines/Rev Rotary Encoder	N/A
Electronic Resolution	0.565 arc sec (0.000157°)	0.785 arc sec (0.000218°) @ 480 steps/rev motor resolution	0.324 arc sec (0.00009°)	0.324 arc sec (0.00009°) @ 40000 steps/rev motor resolution
Maximum Bus Voltage	48 VDC	48 VDC*	48 VDC	48 VDC*
* With Aerotech control system		Optical Switch	Optical Switch	Optical Switch

Recommended Controller		MPS50GR DC Servomotor (-M1)	MPS50GR Stepper Motor (-M2)	MPS75GR DC Servomotor (-M1)	MPS75GR Stepper Motor (-M2)
Multi-Axis	A3200	Npaq/Npaq MR/Ndrive MP			
	Ensemble	Ensemble LAB/Epaq/Epaq MR/Ensemble MP			
Single Axis	Soloist	Soloist MP			

MPS-GR Series SPECIFICATIONS

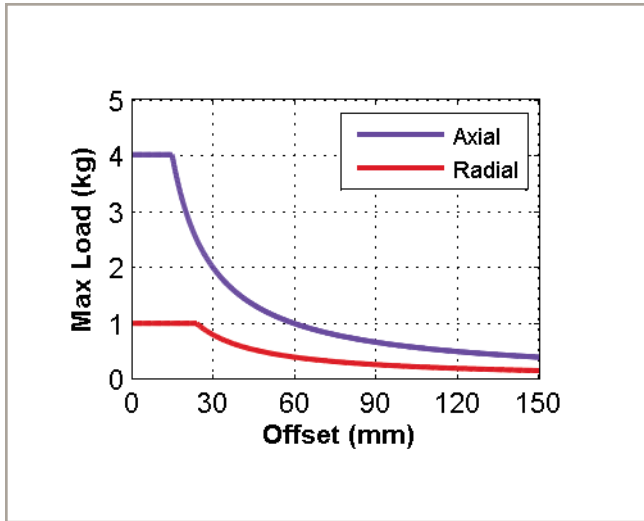

MPS50GR maximum load versus offset.

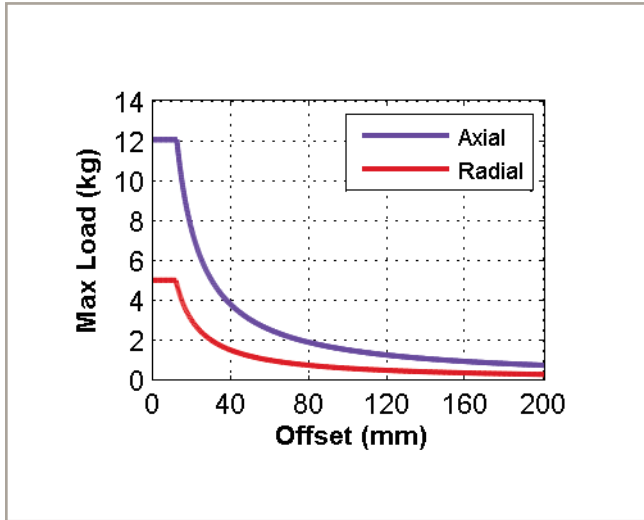
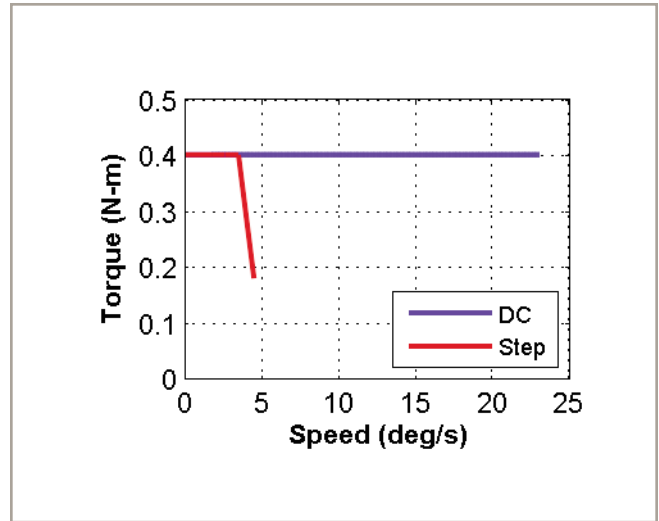

MPS75GR maximum load versus offset.

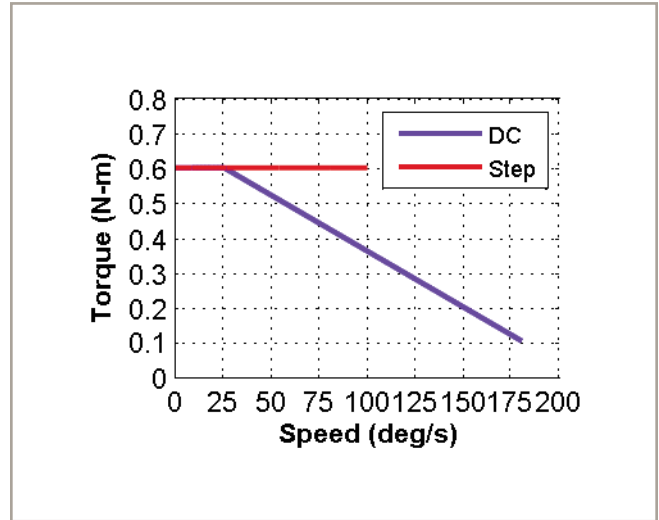

MPS75GR continuous torque versus speed.

MPS-GR Series DIMENSIONS

MPS50GR

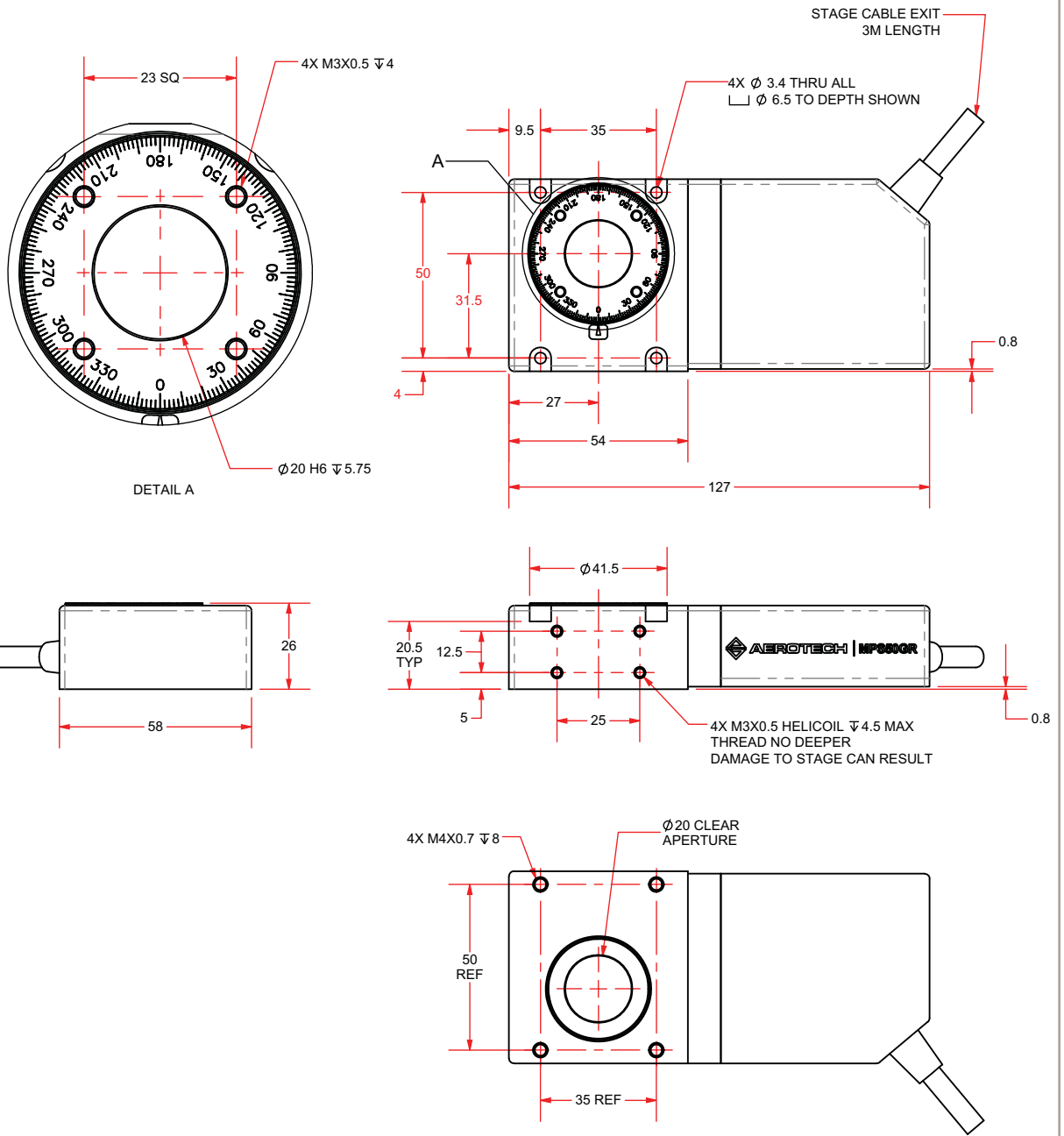
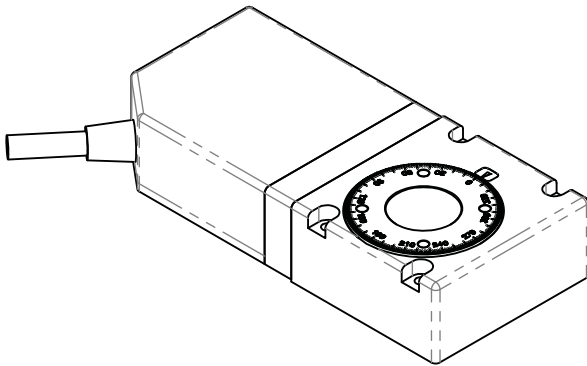

MPS-GR Series DIMENSIONS

MPS50GR-MP

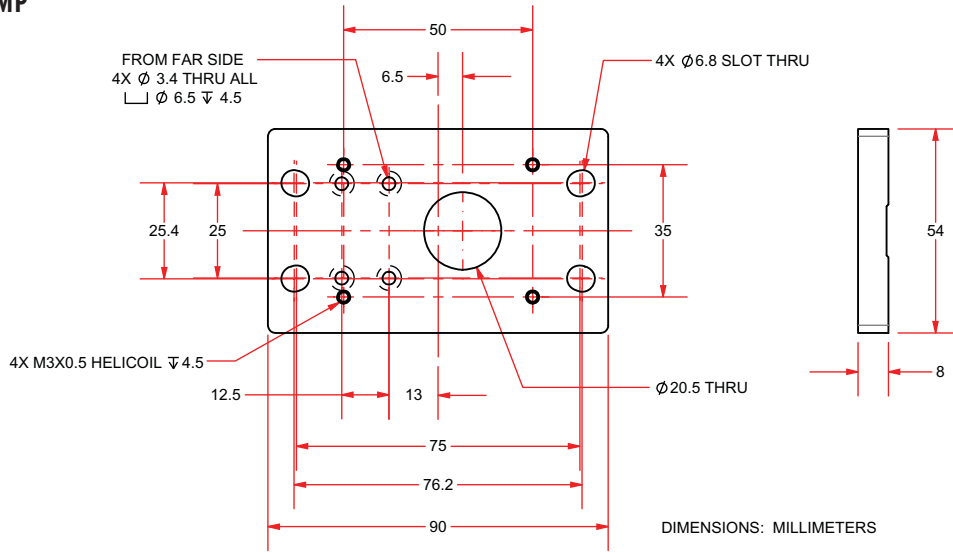

MPS50GR-LM0

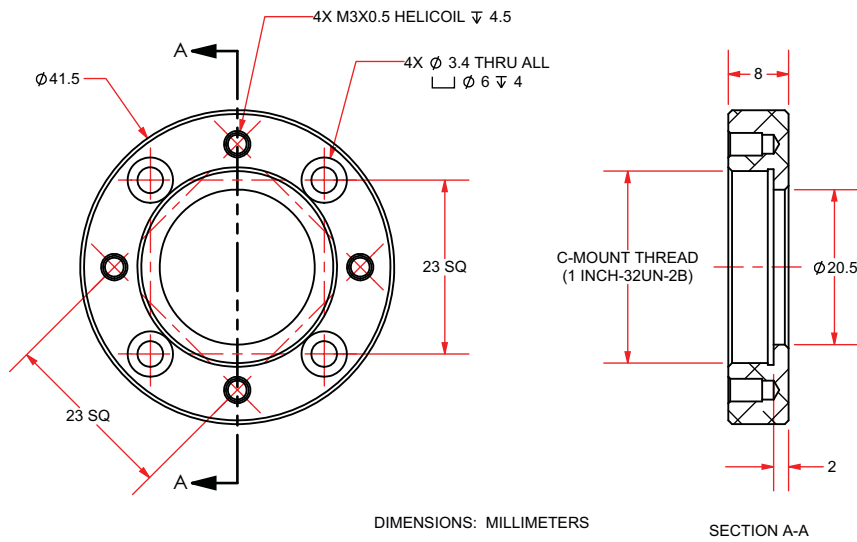

MPS-GR Series DIMENSIONS

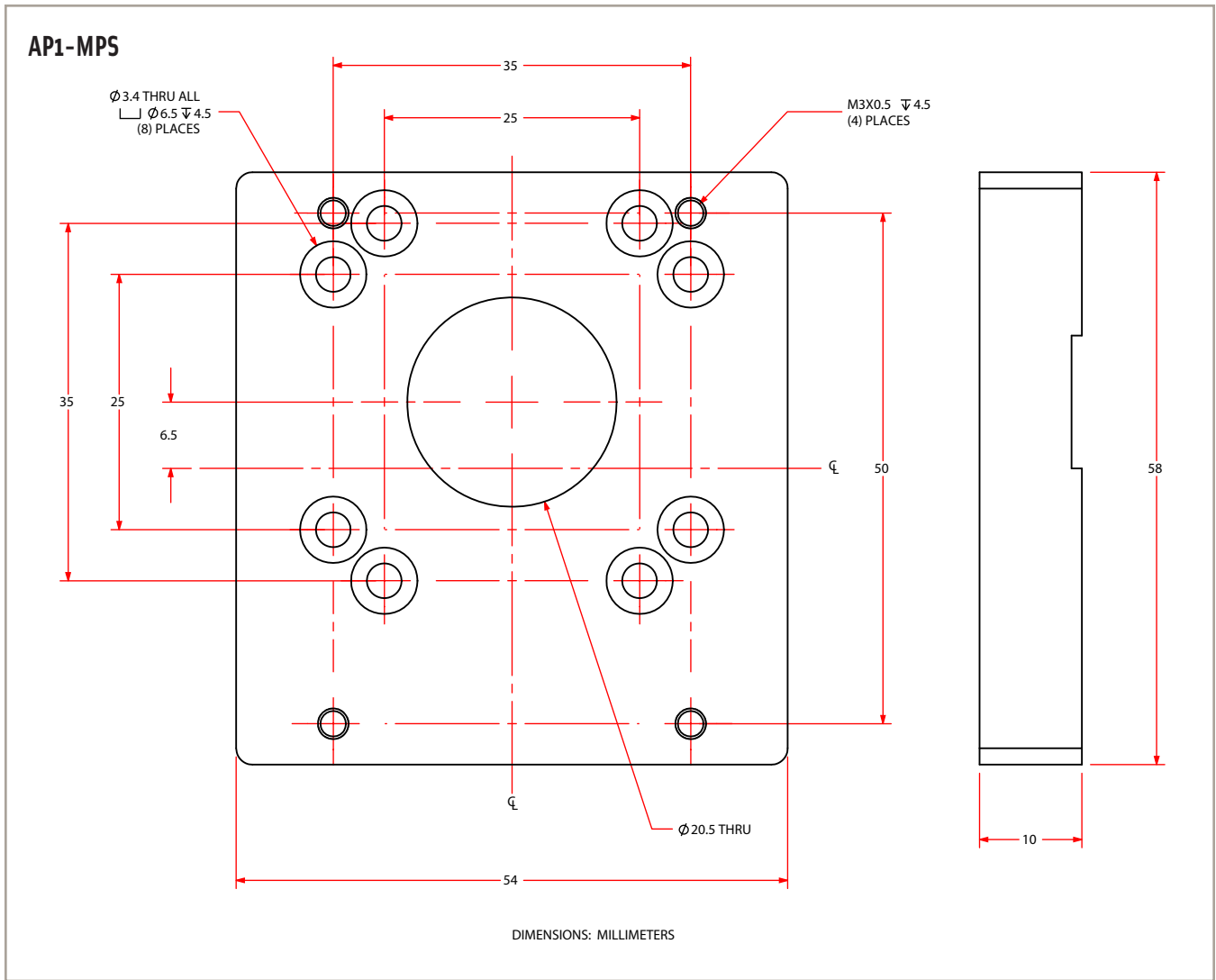

MPS-GR Series DIMENSIONS

HDZ-MPS50GR

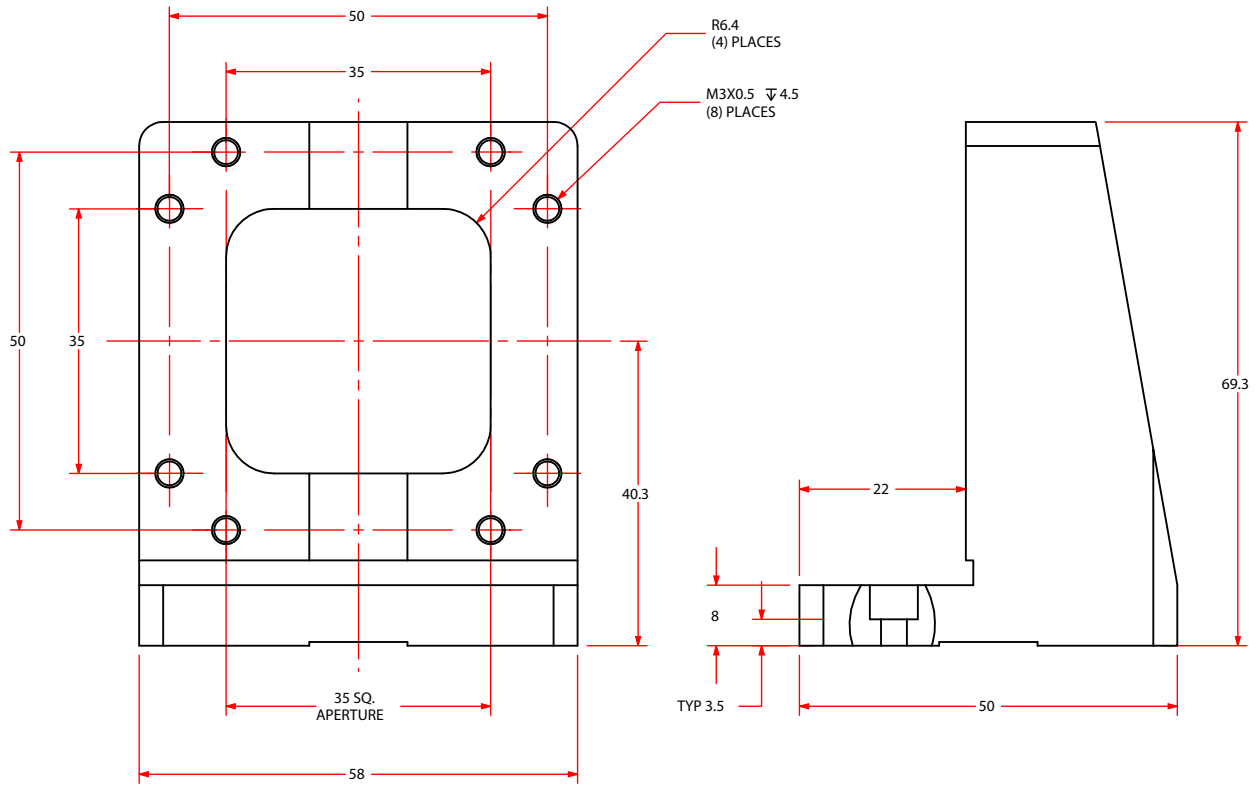
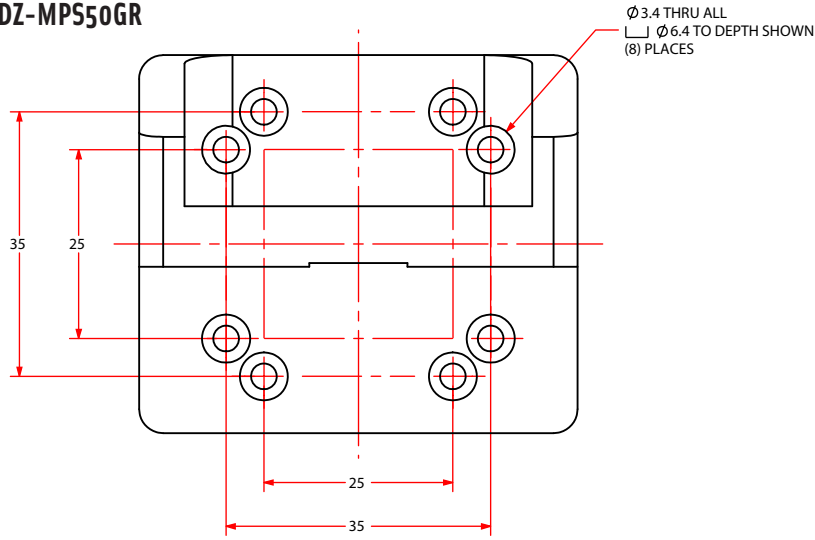

DIMENSIONS: MILLIMETERS

MPS-GR Series DIMENSIONS

MPS75GR

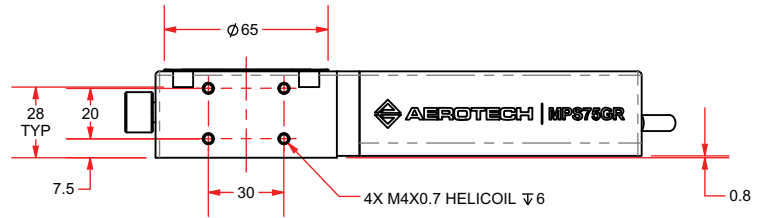
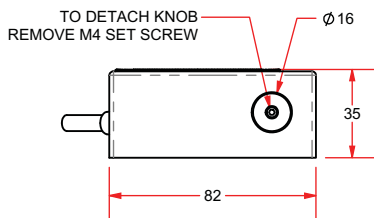
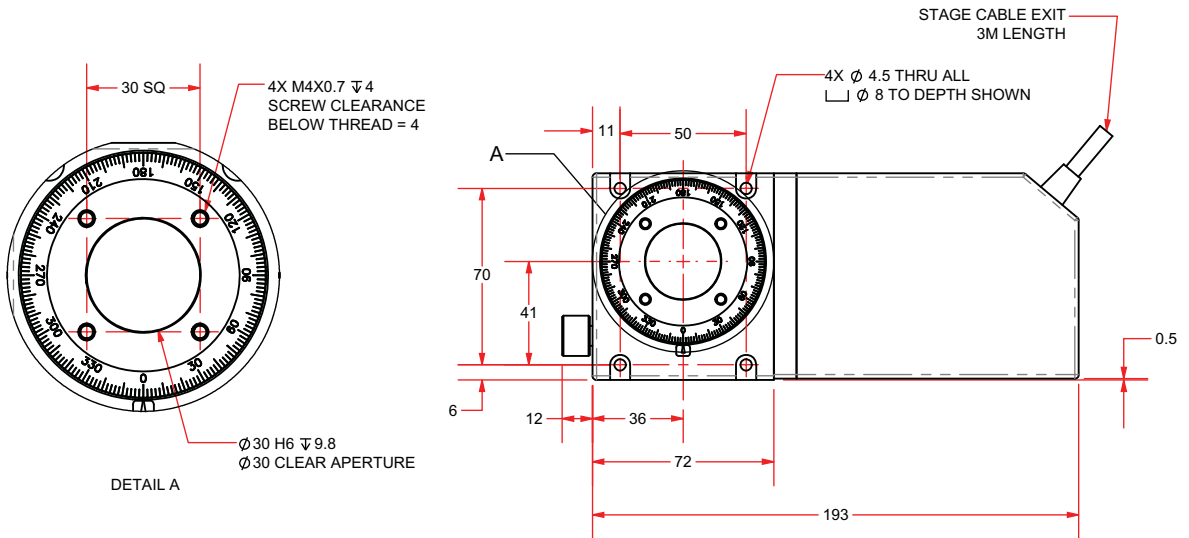
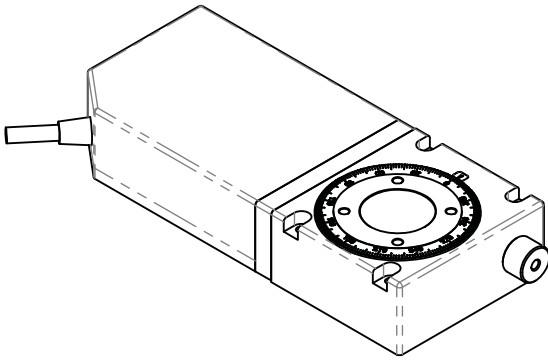

DIMENSIONS: MILLIMETERS

MPS-GR Series DIMENSIONS

MPS75GR-MP

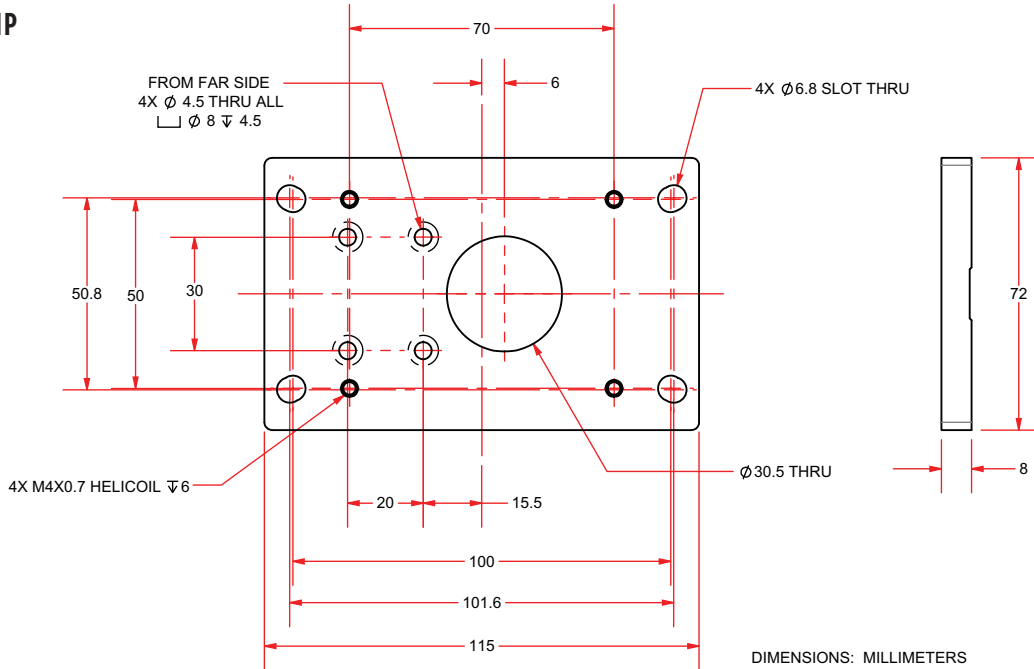

MPS75GR-LMO

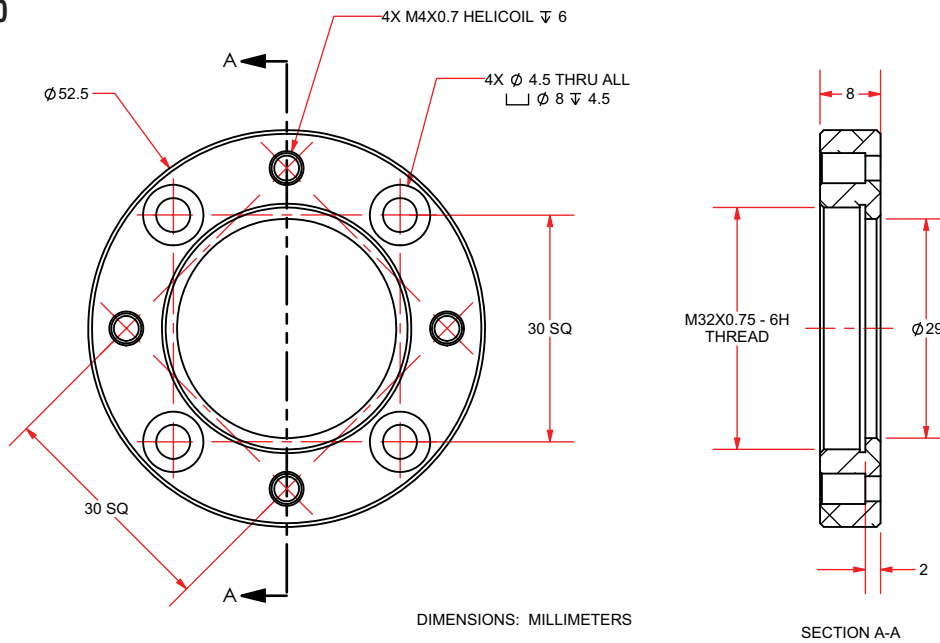

MPS-GR Series DIMENSIONS

HDZ-MPS75GR

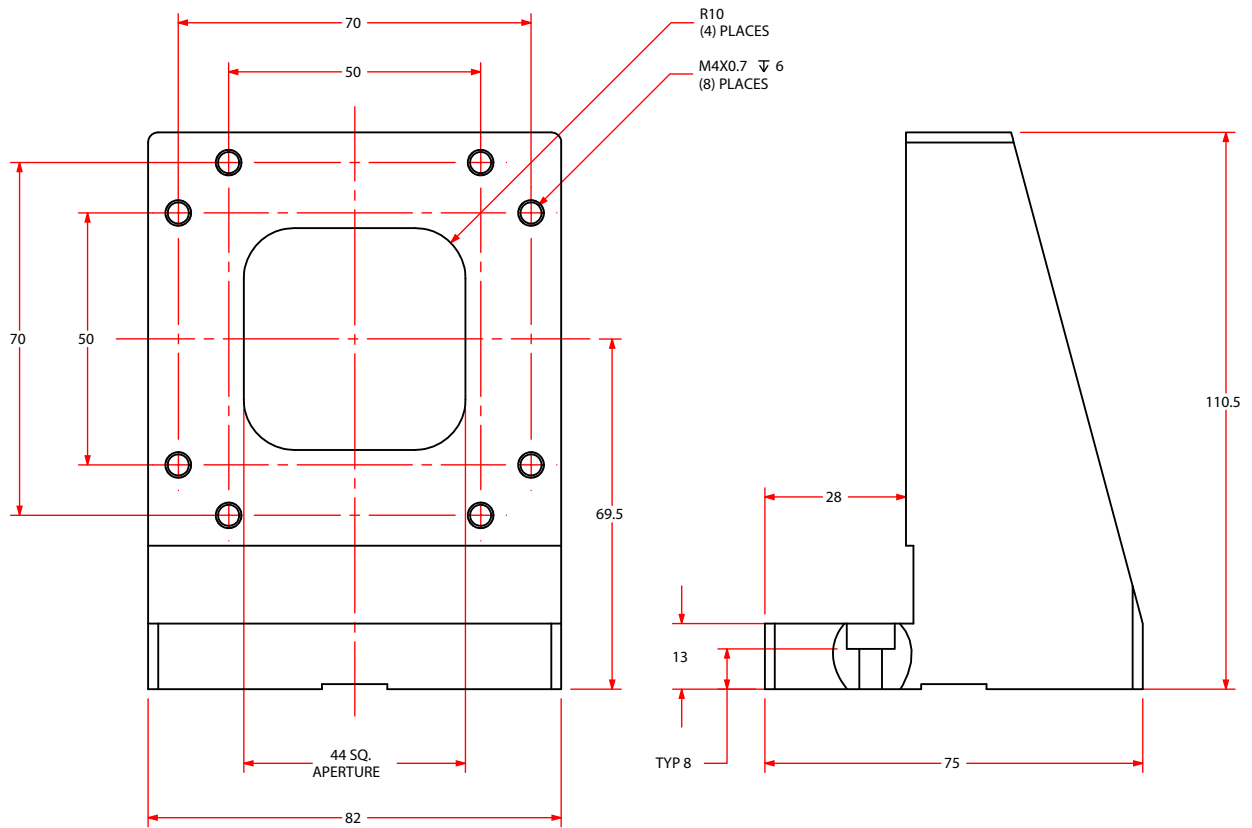
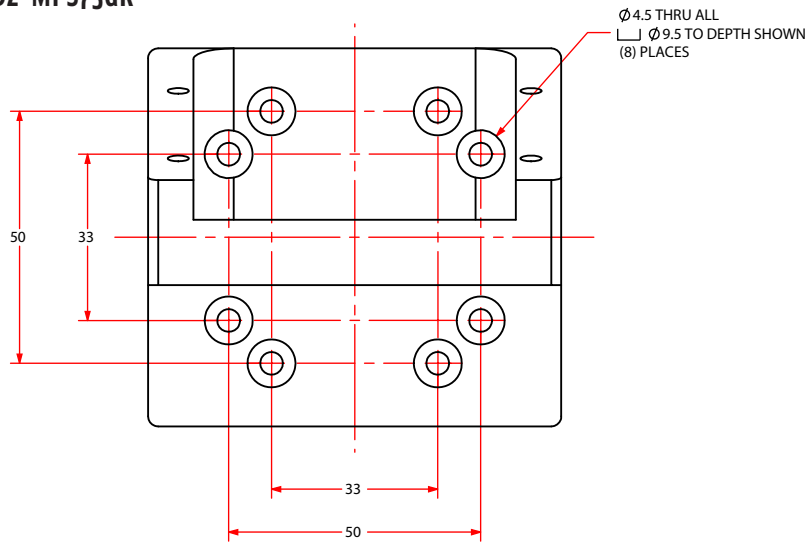

DIMENSIONS: MILLIMETERS

MPS-GR Series ORDERING INFORMATION

MPS-GR Series Miniature Gear-Driven Rotary Stage

MPS50GR	MPS50GR miniature gear-driven rotary stage with 20 mm aperture
MPS75GR	MPS75GR miniature gear-driven rotary stage with 30 mm aperture

Vacuum Preparation (Optional)

-HV	High vacuum preparation to 10^{-6} torr
-----	---

Motor (Required)

-M1	DC servomotor
-M2	Stepper motor

Mounting Plate (Optional)

-MP	Optical table mounting plate
-----	------------------------------

Lens Mount (Optional)

-LMO	Aperture lens mount
------	---------------------

Metrology (Required)

-PL0	No metrology performance plots
-PL1	Metrology, uncalibrated with performance plots
-PL2	Metrology, calibrated (HALAR) with performance plots

Integration (Required)

Aerotech offers both standard and custom integration services to help you get your system fully operational as quickly as possible. The following standard integration options are available for this system. Please consult Aerotech if you are unsure what level of integration is required, or if you desire custom integration support with your system.

-TAS	Integration - Test as system Testing, integration, and documentation of a group of components as a complete system that will be used together (ex: drive, controller, and stage). This includes parameter file generation, system tuning, and documentation of the system configuration.
-TAC	Integration - Test as components Testing and integration of individual items as discrete components that ship together. This is typically used for spare parts, replacement parts, or items that will not be used together. These components may or may not be part of a larger system.