

QFOCUS QF46Z

Travels from 100 μm to 300 μm

High stiffness and dynamics resulting in outstanding step-and-settle and scanning performance

High precision, frictionless flexure guidance

Long device lifetime

Superior positioning resolution and linearity with direct-metrology capacitive sensor option

Mounting flexibility with a variety of threaded adapters or mounting holes for custom mounting arrangements

Clear aperture to 29 mm diameter

Aerotech's QFOCUS® QF46Z piezo nanopositioning stage series enables microscope objective and optics positioning at high-speeds with nanometer-level performance. Available in closed-loop travels of 100 μm and 250 μm (120 μm and 300 μm open-loop), the QF46Z provides long travels without sacrificing dynamic operation and nanometer precision.

The QF46Z is designed with next-generation optical instruments and laser machines in mind. For example, the QF46Z can perform better than competitive offerings with larger and heavier higher numerical aperture (NA) objectives due to its higher inherent stiffness. The QF46Z is perfect for any demanding optical application requiring high precision and throughput with long travels.

Precision Mechanical Structure

The QFOCUS QF46Z piezo stages are guided by precision flexures that are optimized using finite element analysis to ensure high-stiffness and long device life. The resulting design offers outstanding stiffness and resonant frequency enabling high process throughput and fast closed-loop response.



The QFOCUS QF46Z objective focusing stages are ideal for precision optics focusing and microscopy.

In addition, the QF46Z has been designed to provide excellent geometric performance (straightness and angular errors) for critical microscopy and optics positioning applications.

High-Resolution and Positioning Accuracy

The QF46Z piezo stages have the option of closed-loop feedback (-C) using a unique capacitive sensor design that results in sub-nanometer resolution and high linearity. The capacitive sensors measure the output of the positioning carriage directly enabling superior accuracy and repeatability.

Ultra-Precision Control

When coupled with Aerotech's Q-series controllers and drives, the QF46Z demonstrates sub-nanometer positioning resolution, in-position stability (jitter), and high-positioning bandwidth. Software options such as Aerotech's Dynamic Controls Toolbox and Motion Designer packages provide a host of advanced yet easy-to-use tools such as Learning Control, Harmonic Cancellation, and Command Shaping, providing improved tracking errors and faster step-and-settle times. OEM drive options are also available.

Flexibility

The QFOCUS QF46Z is available with threaded adapters to fit most microscopes and objectives. The microscope turret mounting allows easy and fast positioning of the QF46Z at the desired orientation. In addition, tapped holes on the stage body provide alternative mounting for custom interfaces in machines or other optical instruments. The QF46Z is available with a clear aperture up to 29 mm. Custom stage designs, travels, and threaded adapters are available.

QFOCUS QF46Z Series SPECIFICATIONS

Mechanical Specifications		QF46Z-100	QF46Z-250
Closed-Loop Travel		100 μm	250 μm
Open-Loop Travel, -30 to +150 V ⁽¹⁾		120 μm	300 μm
Resolution ⁽²⁾	Closed-Loop	0.30 nm	0.50 nm
	Open-Loop	0.15 nm	0.2 nm
Linearity ^(3,4)		0.01%	0.01%
Bidirectional Repeatability ⁽⁵⁾		2.5 nm	3 nm
Pitch/Yaw		10 μrad (2.1 arc sec)	10 μrad (2.1 arc sec)
Straightness (XY)		15 nm	15 nm
Stiffness (in direction of motion) ⁽⁶⁾		1.20 N/ μm	0.41 N/ μm
Unloaded Resonant Frequency ⁽⁶⁾		750 Hz	430 Hz
Resonant Frequency (150 g load) ^(6,7)		260 Hz	180 Hz
Max Payload ⁽⁸⁾		1 kg	1 kg
Maximum Acceleration (Unloaded) ⁽⁹⁾		350 m/s ²	275 m/s ²
Moving Mass (No Objective)		56 g	61 g
Stage Mass ⁽¹⁰⁾		0.21 kg	0.21 kg
Material		Anodized Aluminum/Brass ⁽¹¹⁾	
MTBF (Mean Time Between Failure)		30,000 Hours	

Notes:

- Value $\pm 10\%$.
- See Piezo Engineering reference section 4.2 for description of resolution.
- Certified with each stage (closed-loop feedback models only).
- See Piezo Engineering reference section 4.1 for description of linearity and accuracy specifications.
- Specified as a 1 sigma (standard deviation) value (closed-loop feedback models only). See Piezo Engineering reference section 4.3 for description of bidirectional repeatability.
- Values $\pm 20\%$.
- Loaded resonance can vary as a function of objective size/geometry.
- On-axis loading listed.
- Max acceleration listed is the stage mechanical limitation. Achievable acceleration is a function of amplifier selection and move parameters.
- Stage mass includes microscope adapter (-MA1) and objective adapter (-OA1).
- External elements are anodized aluminum. Brass used for threaded adapters. Some stainless steel components are used in the internal construction. Other materials upon request.

Electrical Specifications	QF46Z-100	QF46Z-250
Drive System	Piezo Multi-Layer Stack Actuator	
Feedback	Closed-Loop: Integrated Capacitive Sensor (-C) Open-Loop: None (-)	
Max Voltage	-30 V to +150 V	
Piezo Stack Capacitance ⁽¹⁾	1.6 μF	2.3 μF

- Value $\pm 20\%$

Recommended Controller	
Ensemble	Ensemble QLAB Ensemble QDe Ensemble QLe Ensemble QL
A3200	Ndrive QLe Ndrive QL

- Unless noted the QLAB, QDe, or QLe are required to achieve the listed specifications. Contact Aerotech for specifications when used with the QL drives.

QFOCUS QF46Z Series DIMENSIONS

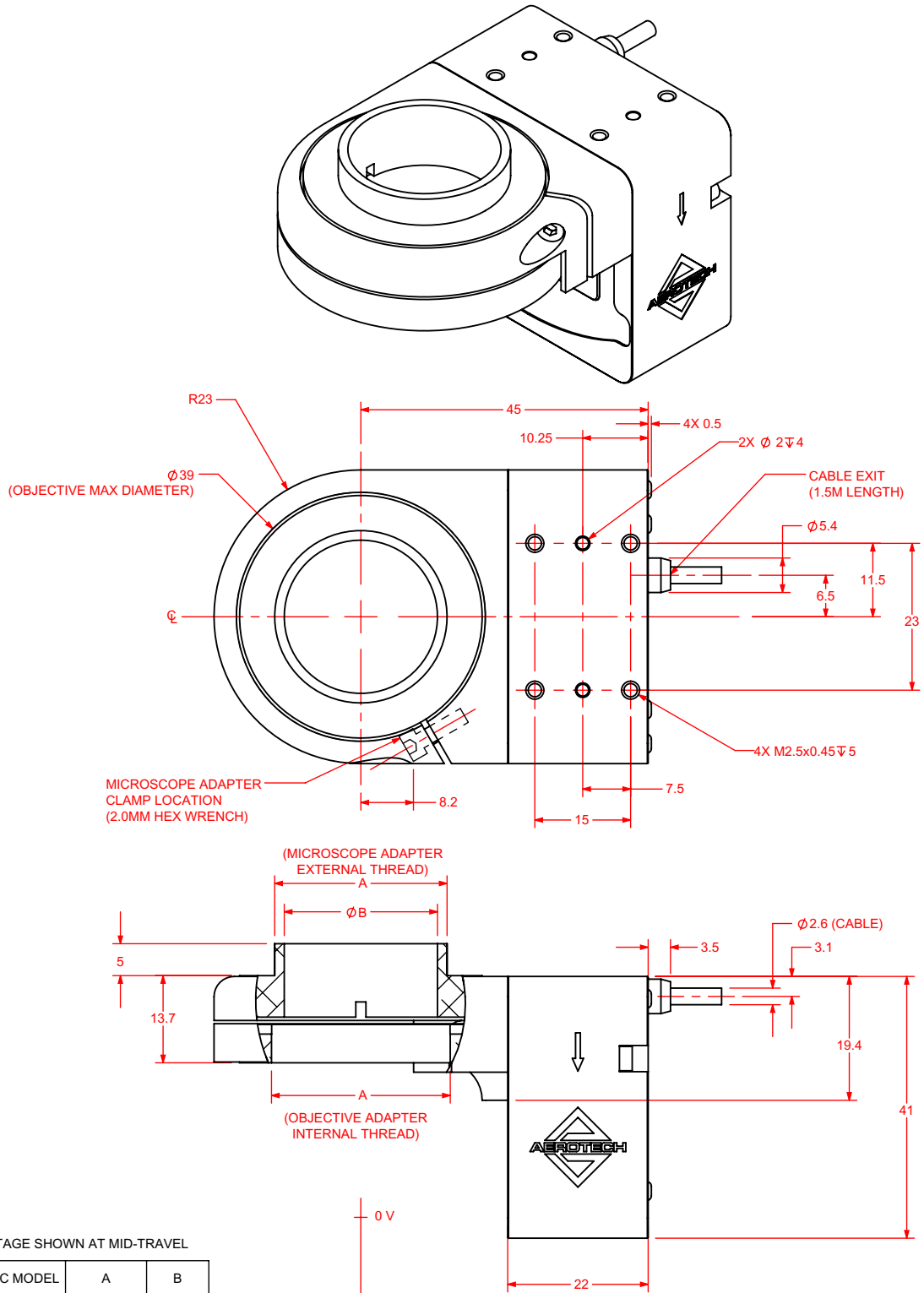

STAGE SHOWN AT MID-TRAVEL

BASIC MODEL	A	B
QF46Z-100 QF46Z-250	M19x0.75	14
	M25x0.75	22
	M26x0.75	23
	M27x0.75	24
	M28x0.75	25
	M32x0.75	29
	M26x1/36"	23
W0.8x1/36"	14	

DIMENSIONS: MILLIMETERS

QFOCUS QF46Z ORDERING INFORMATION

Travel (Required)

-100	100 μm closed-loop travel, 120 μm open-loop travel
-250	250 μm closed-loop travel, 300 μm open-loop travel

Feedback (Optional)

-C	Capacitance sensor feedback
----	-----------------------------

Microscope Adapter (Optional)

-MA1	W0.8 x 1/36" microscope adapter
-MA2	M19 x 0.75 microscope adapter
-MA3	M25 x 0.75 microscope adapter
-MA4	M26 x 0.75 microscope adapter
-MA5	M27 x 0.75 microscope adapter
-MA6	M28 x 0.75 microscope adapter
-MA7	M32 x 0.75 microscope adapter
-MA8	M26 x 1/36" microscope adapter

Objective Adapter (Optional)

-OA1	W0.8 x 1/36" objective adapter
-OA2	M19 x 0.75 objective adapter
-OA3	M25 x 0.75 objective adapter
-OA4	M26 x 0.75 objective adapter
-OA5	M27 x 0.75 objective adapter
-OA6	M28 x 0.75 objective adapter
-OA7	M32 x 0.75 objective adapter
-OA8	M26 x 1/36" objective adapter

Integration (Required)

Aerotech offers both standard and custom integration services to help you get your system fully operational as quickly as possible. The following standard integration options are available for this system. Please consult Aerotech if you are unsure what level of integration is required, or if you desire custom integration support with your system.

-TAS	<p>Integration - Test as system</p> <p>Testing, integration, and documentation of a group of components as a complete system that will be used together (ex: drive, controller, and stage). This includes parameter file generation, system tuning, and documentation of the system configuration.</p>
-TAC	<p>Integration - Test as components</p> <p>Testing and integration of individual items as discrete components that ship together. This is typically used for spare parts, replacement parts, or items that will not be used together. These components may or may not be part of a larger system.</p>