

ARMS Series

Rotary Motion Simulators

Designed for highly accurate motion generation

Velocity stability of 0.0001% over 360°

Position resolution to 0.02 arc sec

Payloads to 230 kg

Integrated slip rings and optional rotary unions

Direct-drive brushless motor options for high speed or high torque



Aerotech's ARMS series direct-drive rotary motion simulators provide superior angular rates, accelerations, and positioning for the testing of inertial components and systems such as MEMS, gyroscopes, inertial measurement units, avionics, and accelerometers.

Accurate Velocity and Positioning

The ARMS family of stages provides excellent velocity and positioning control. When coupled with Aerotech's advanced controls, resolution can be as fine as 0.02 arc second, with accuracy to ± 2.5 arc second and repeatability to ± 0.5 arc second. The motor and high-performance rotary encoder are directly coupled to a common shaft. The absence of gear trains and mechanical couplings means no position errors caused by hysteresis, windup, or backlash. The ARMS has rate resolution down to 0.001 deg/s and rate stability to 0.0001%.

Superior Mechanical Design

Dual large-diameter bearings are used to maximize performance with respect to wobble, moment stiffness, and repeatability. The large diameter bearings permit large payloads without compromising performance.

Brushless Direct-Drive

The ARMS series utilizes Aerotech's S-series brushless, slotless motor to maximize positioning performance. The S-series motor provides all of the advantages of a brushless direct-drive motor – no brushes to wear, no gear trains to maintain, and high acceleration and high speeds. The slotless, ironless design eliminates cogging and, therefore,

produces absolutely no torque ripple. With its low inherent inertia and optimized motor design, the ARMS is capable of speeds and accelerations that are significantly higher than competing products. Low inertia and zero backlash make the ARMS the ideal solution for applications requiring frequent directional changes.

Flexible Configurations

Slip rings and rotary unions are standard options available to ease integration of customer devices. With various tabletop styles as well as optional HDP pedestals, customers can also tailor the mechanical interface of the ARMS stages to suit many different needs.

Advanced User-Friendly Controls

Aerotech rate tables are controlled with state-of-the-art Aerotech controls and drives. Our software packages are available as stand-alone applications, where no other language or compiler is needed, as well as LabVIEW®, C, and .NET software interfaces. Users can graphically generate their own motion profiles and execute them automatically with Aerotech's GUI Motion Designer software. Or, for users who already have their own motion simulation software, our software can easily accept files with arrays of velocity, position, and acceleration versus time profiles. This is then downloaded and run on the ARMS by our motion control software.

ARMS Series SPECIFICATIONS

ARMS Series		ARMS150-M1	ARMS150-M2	ARMS200-M1	ARMS200-M2	ARMS260-M1	ARMS260-M2
Width		146 mm		196 mm		260 mm	
Height ⁽¹⁾		183 mm	246 mm	224 mm	249 mm	229 mm	250 mm
Aperture ⁽²⁾		8 mm				25 mm	
Total Travel		±360° Continuous					
Bus Voltage		Up to 340 VDC					
Maximum Torque (Continuous)		2.36 N·m	7.69 N·m	11.12 N·m	15.93 N·m	19.71 N·m	29.09 N·m
Fundamental Encoder Resolution		16,200 lines/rev		23,600 lines/rev		32,400 lines/rev	
Accuracy ⁽³⁾		±2.5 arc sec					
Repeatability		±0.5 arc sec					
Max Load ⁽⁴⁾	Axial	30 kg		140 kg		230 kg	
Max Load ⁽⁴⁾	Moment	175 N·m		425 N·m		650 N·m	
Tilt Error Motion		±1 arc sec					
Maximum Rate ⁽⁵⁾		1500°/s					
Minimum Rate ⁽⁶⁾		0.002°/s				0.001°/s	
Rate Resolution ⁽⁶⁾		0.002°/s				0.001°/s	
Rate Stability ⁽⁶⁾	Over 360°	0.0001%					
	Over 10°	0.005%					
	Over 1°	0.05%					
Peak Acceleration ⁽⁷⁾		>20,000°/s ²					
Inertia (unloaded) ⁽⁷⁾		6,600 kg·mm ²	9,700 kg·mm ²	33,600 kg·mm ²	39,800 kg·mm ²	115,200 kg·mm ²	139,000 kg·mm ²
Total Mass ⁽⁷⁾		9 kg	15 kg	22 kg	26 kg	39 kg	44 kg
Servo Bandwidth ⁽⁸⁾		>70 Hz (-3 dB)					
Material		Aluminum					
Stage Finish		Black Anodize					
Tabletop Finish		Hard Coating (62 Rockwell Hardness)					

Notes:

- Height may vary with certain slip ring and rotary union options. See product dimensional drawings for more details.
- Aperture not available with all slip ring and rotary union options. See ordering information for more details.
- Certified with each stage. Requires the use of an Aerotech controller.
- Maximum loads are mutually exclusive.
- Maximum rate is based on stage capability. Actual rate may depend on encoder resolution, load, amplifier bus voltage and motor. See the S-series rotary motor for more information.
- Minimum rate, rate resolution and rate accuracy are based on stage capability. Actual rate, resolution and accuracy may depend on encoder resolution.
- Peak acceleration, inertia and total mass based on unloaded stage with standard diameter tabletop.
- Servo bandwidth is based on unloaded stage with standard diameter tabletop. Actual bandwidth may depend on mass and inertia of stage payload.

ARMS150

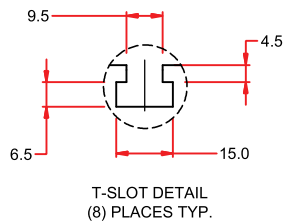
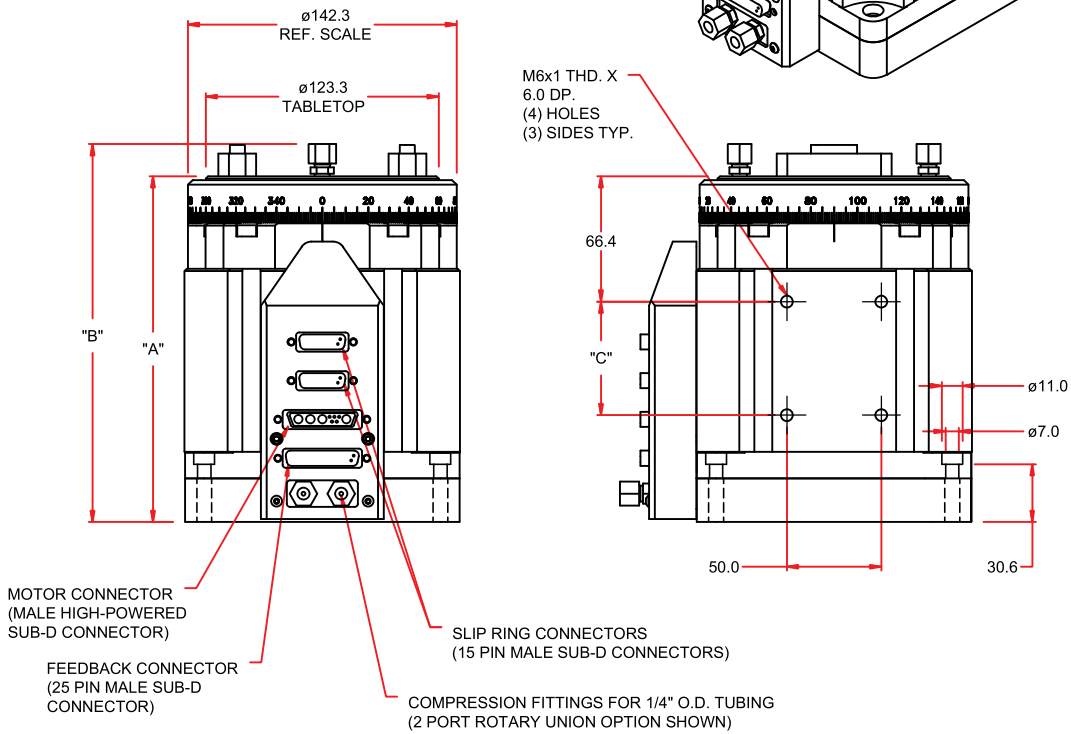
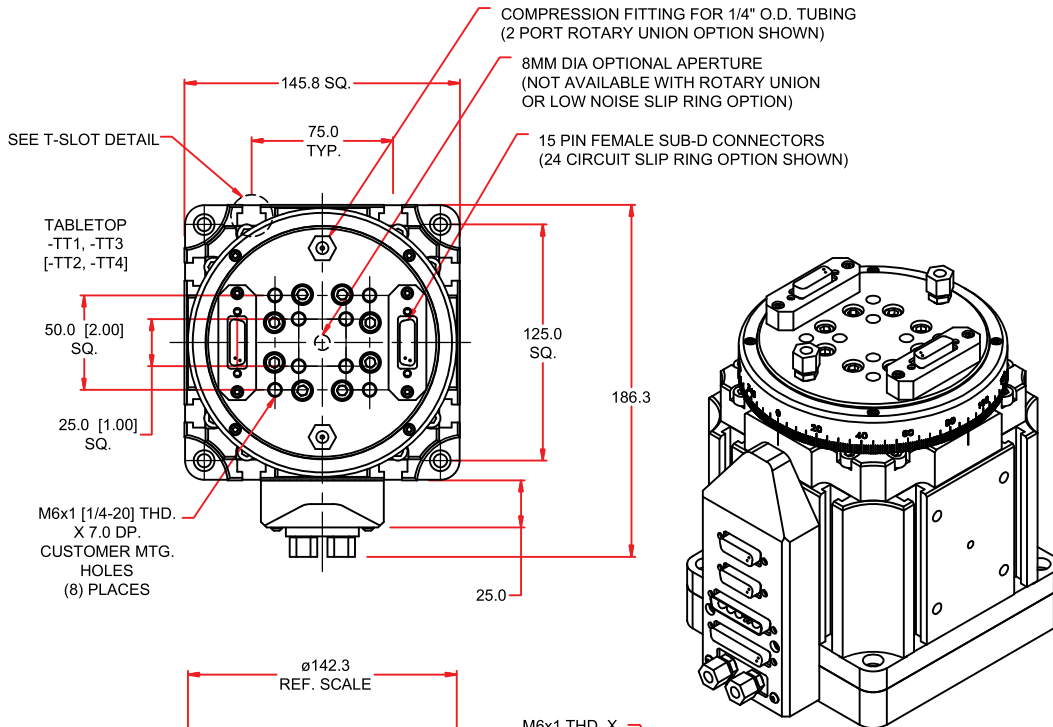

DIMENSIONS - MILLIMETERS			
BASIC MODEL	"A"	"B"	"C"
ARMS150-M1	183.0	200.1	60.0
ARMS150-M2	246.0	263.1	120.0

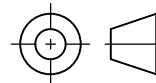

ARMS150-LD

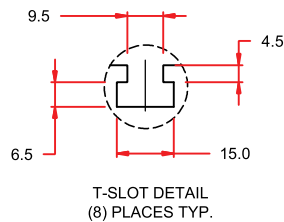
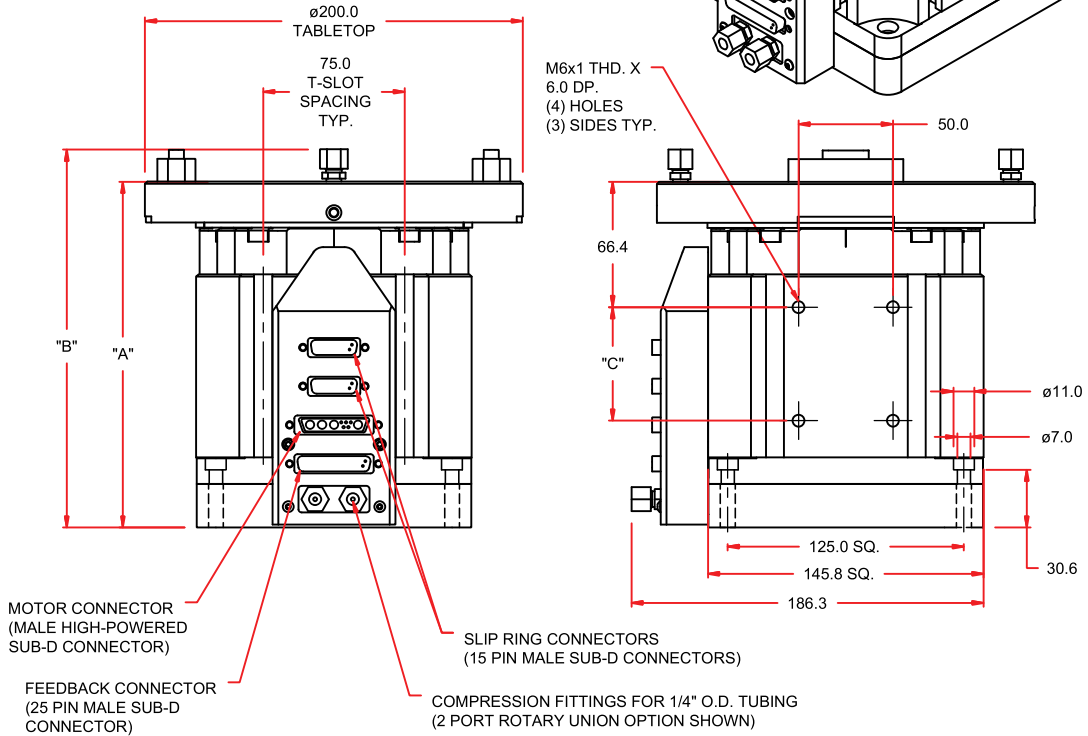
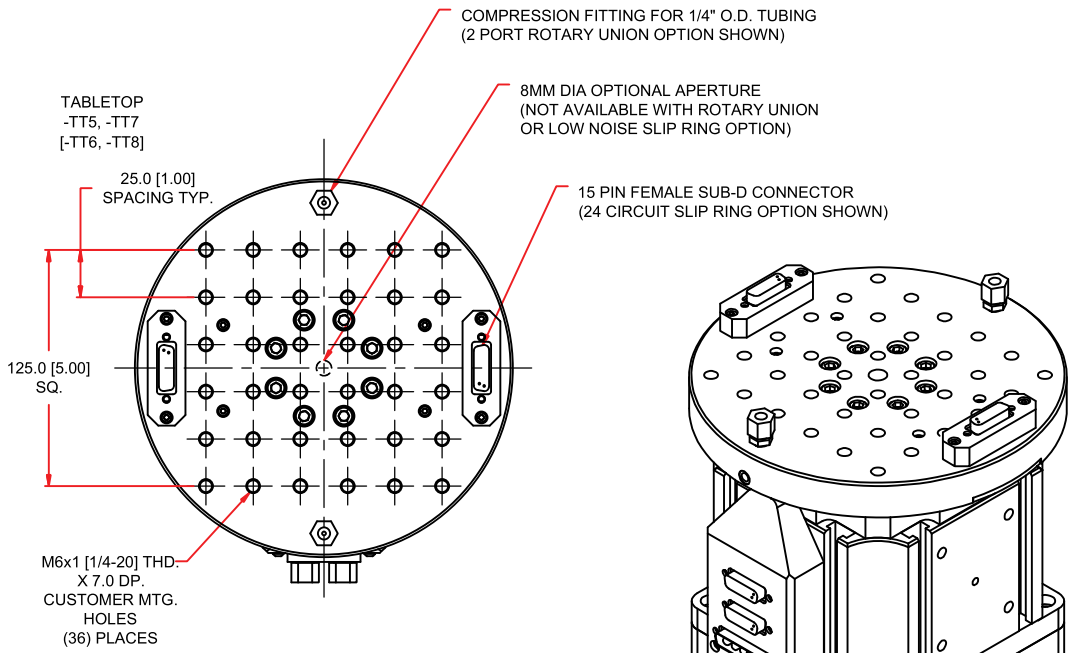

DIMENSIONS - MILLIMETERS			
BASIC MODEL	"A"	"B"	"C"
ARMS150-M1	183.0	200.1	60.0
ARMS150-M2	246.0	263.1	120.0

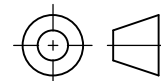

HPD150 DIMENSIONS

HPD150

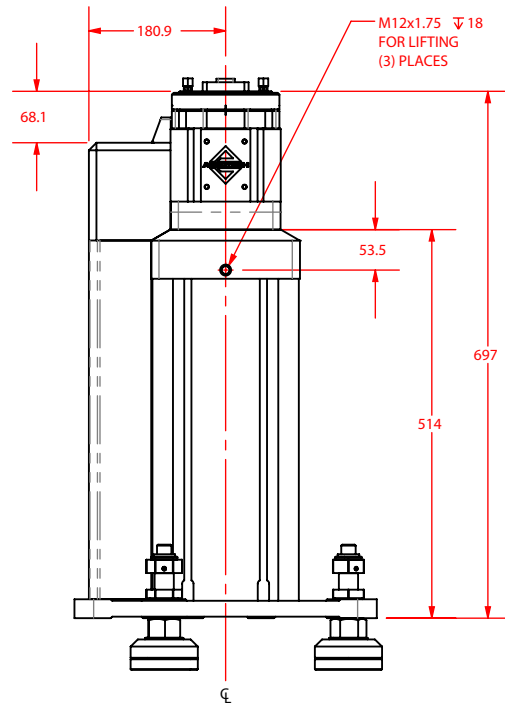
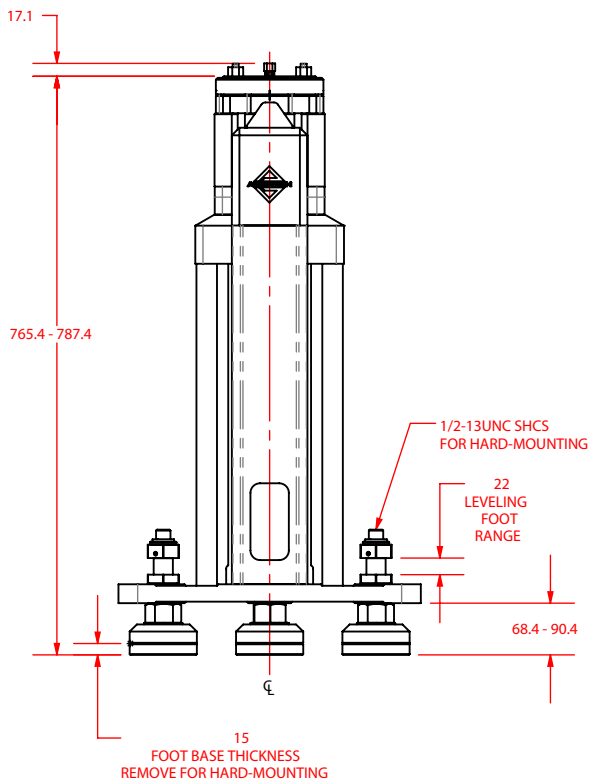
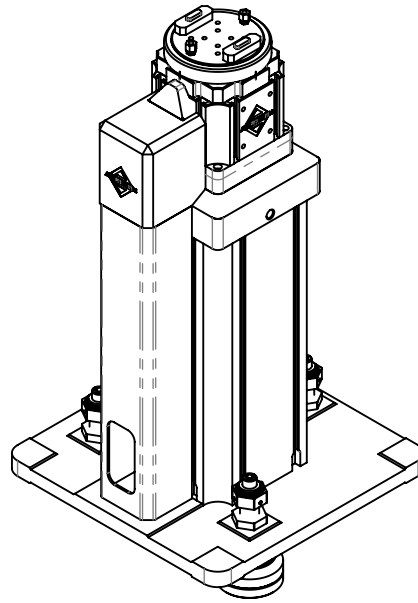
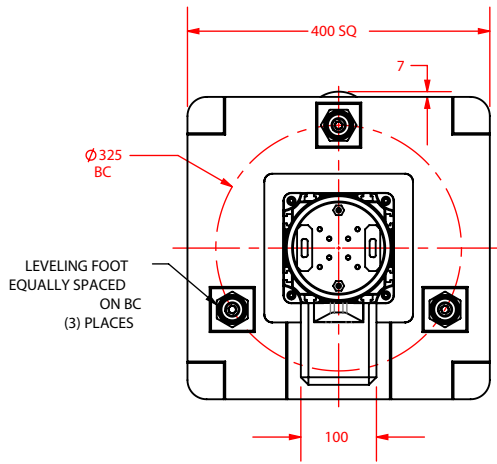

NOTES:

1. SEE ARMS150 DRAWING FOR STAGE DETAILS.
2. HDP150 AS SHOWN IS CONFIGURED FOR -M1 MOTOR. CONSULT FACTORY FOR ALTERNATE CONFIGURATIONS.
3. ALL SLIP RING OPTIONS AVAILABLE.
4. ALL MOUNTING AND GRID PATTERNS AVAILABLE.
5. ALL ROTARY UNIONS OPTIONS AVAILABLE.

DIMENSIONS: MILLIMETERS

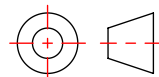

ARMS200

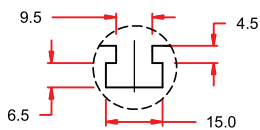
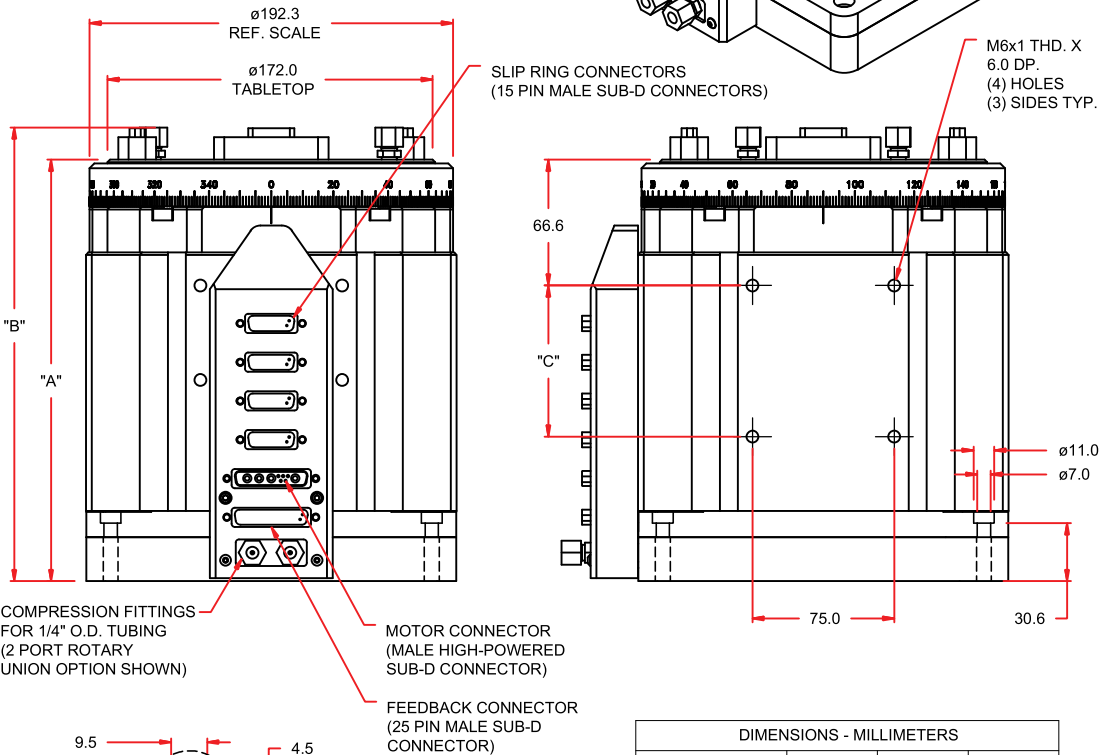
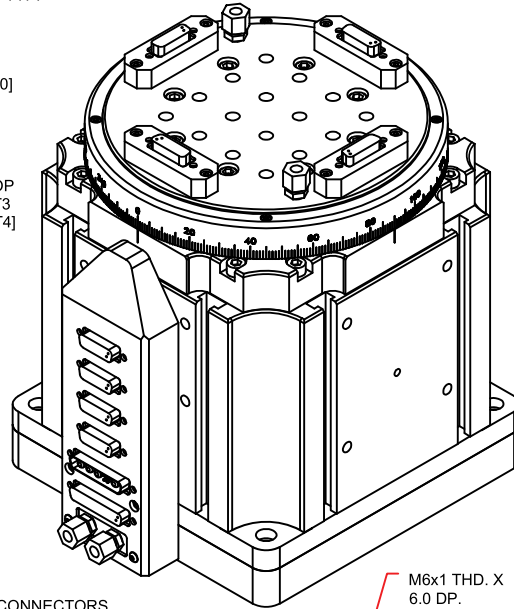
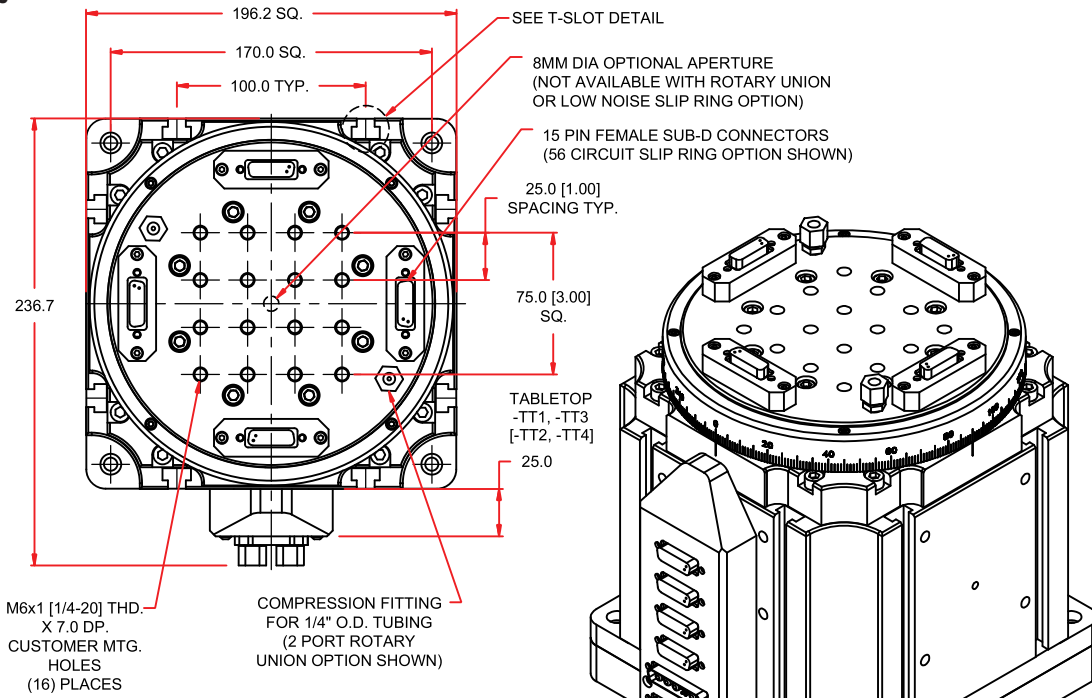

T-SLOT DETAIL
(8) PLACES TYP.

DIMENSIONS - MILLIMETERS			
BASIC MODEL	"A"	"B"	"C"
ARMS200-M1	223.0	240.1	80.0
ARMS200-M2	248.0	265.1	100.0

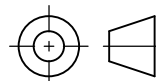

ARMS Series DIMENSIONS

ARMS200-LD

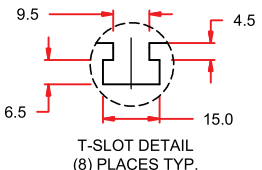
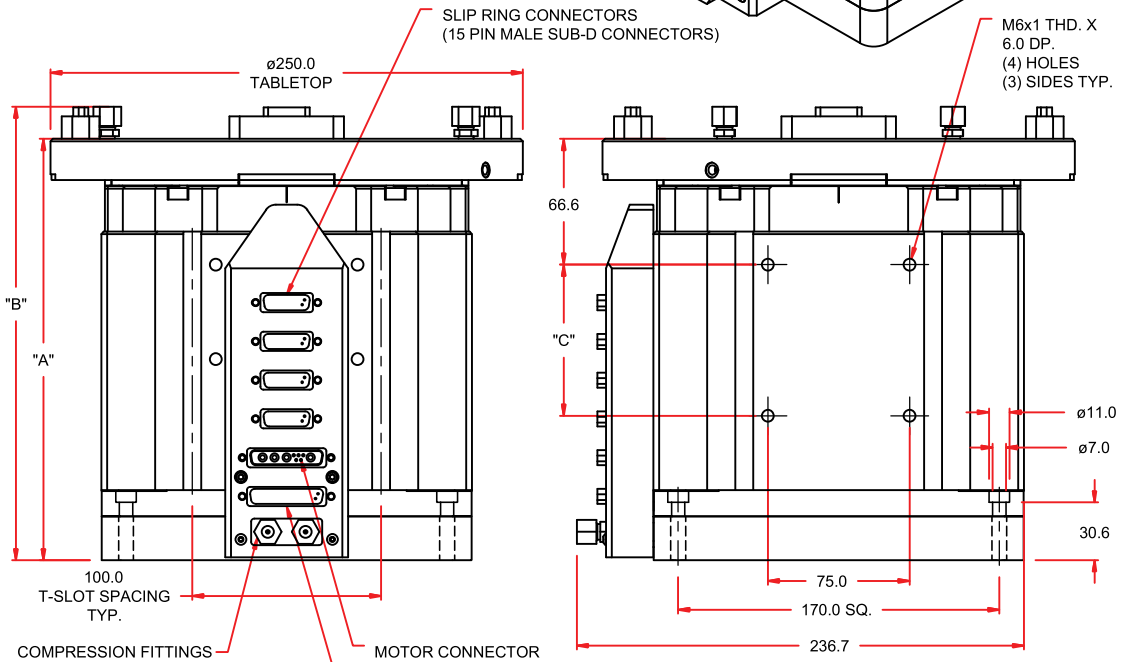
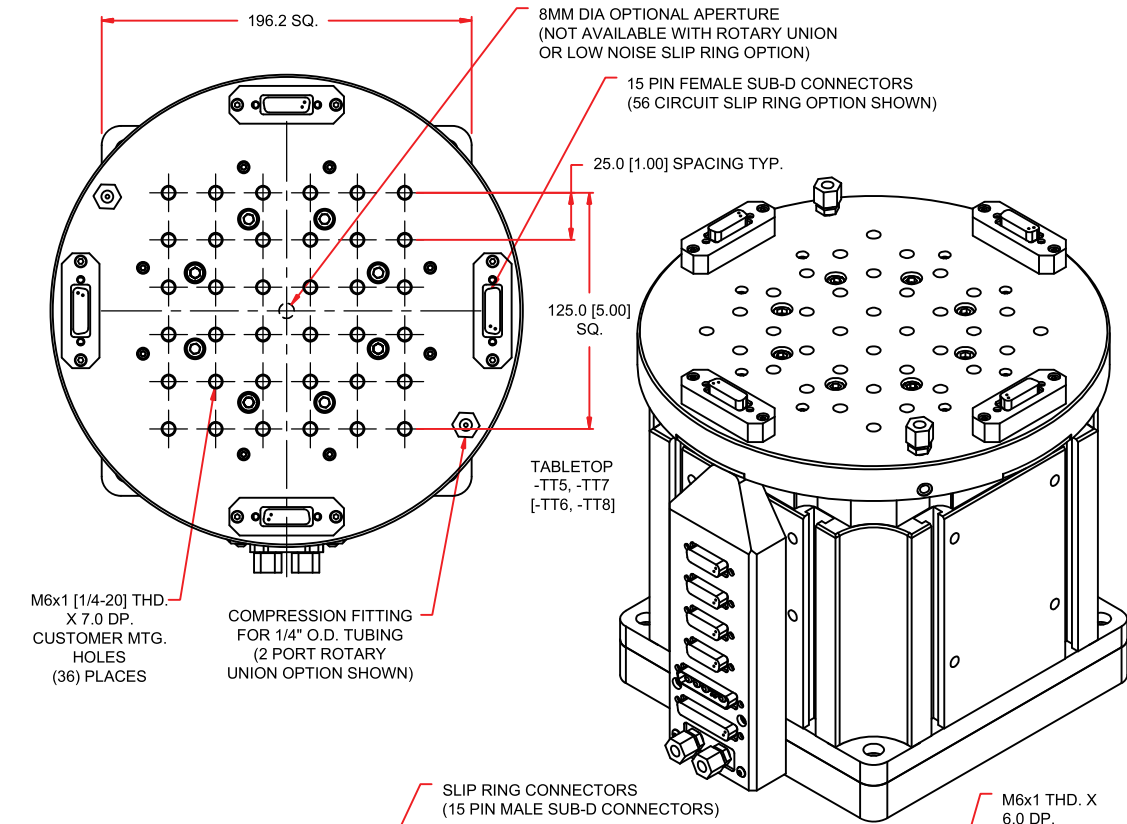

DIMENSIONS - MILLIMETERS			
BASIC MODEL	"A"	"B"	"C"
ARMS200-M1	223.0	240.1	80.0
ARMS200-M2	248.0	265.1	100.0

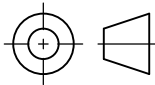

HPD200 DIMENSIONS

HPD200

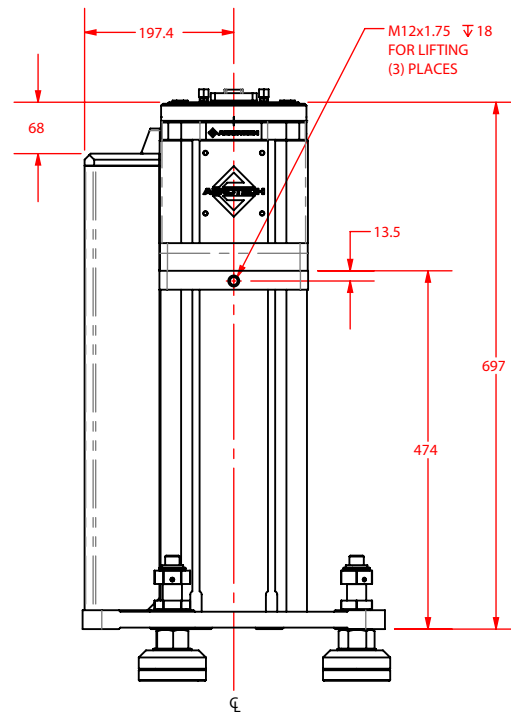
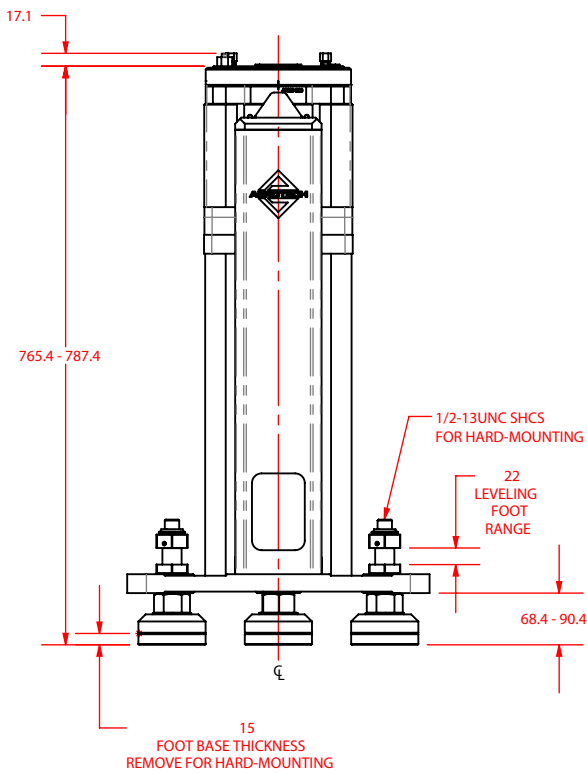
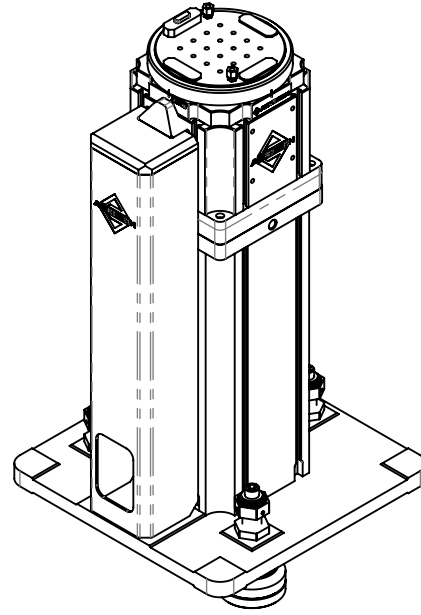
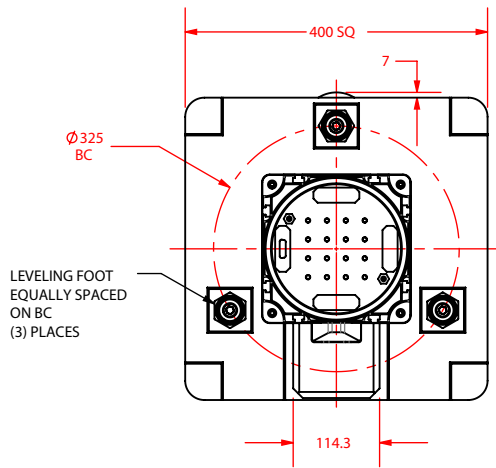

NOTES:

1. SEE ARMS200 DRAWING FOR STAGE DETAILS.
2. HDP200 AS SHOWN IS CONFIGURED FOR -M1 MOTOR. CONSULT FACTORY FOR ALTERNATE CONFIGURATIONS.
3. ALL SLIP RING OPTIONS AVAILABLE
4. ALL MOUNTING AND GRID PATTERNS AVAILABLE
5. ALL ROTARY UNION OPTIONS AVAILABLE

DIMENSIONS: MILLIMETERS

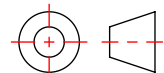

ARMS260

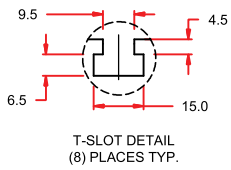
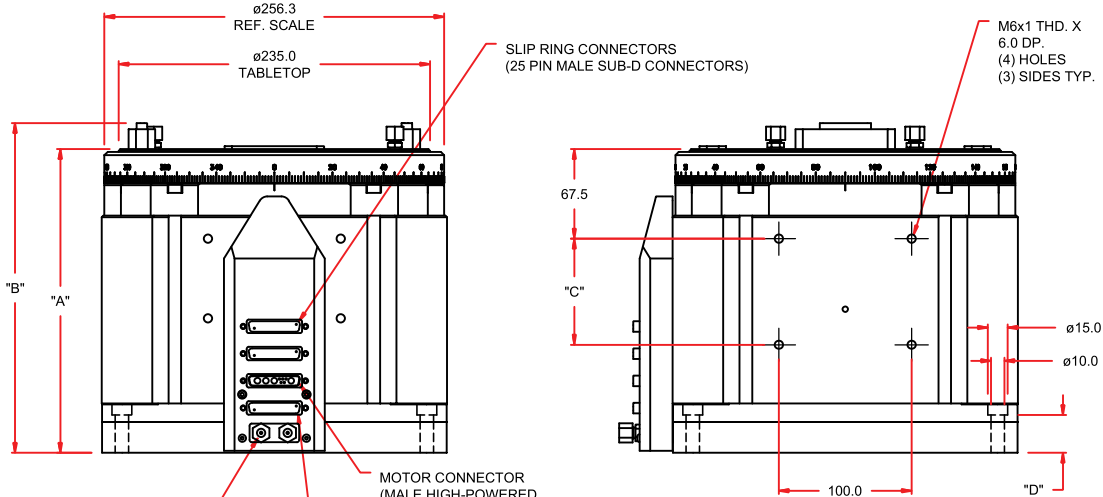
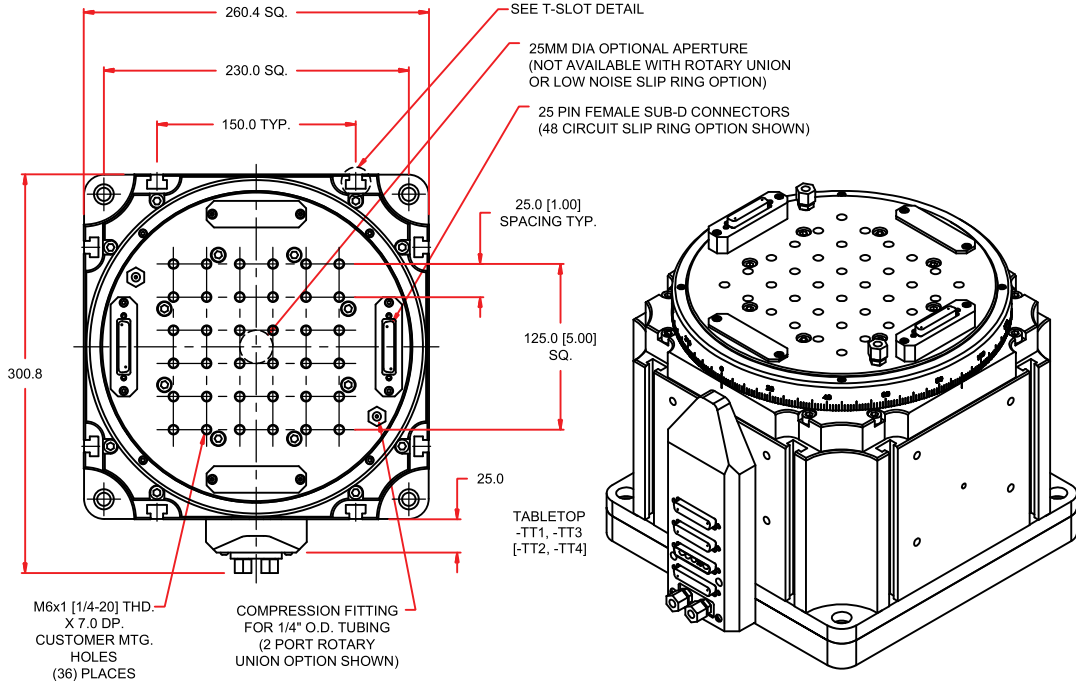

DIMENSIONS - MILLIMETERS

BASIC MODEL	"A"	"B"	"C"	"D"
ARMS260-M1-SR02, -SR09	229.0	248.6	80.0	28.6
ARMS260-M1-SR04, -SR11	229.0	248.6	80.0	28.6
ARMS260-M1-SR06, -SR12	279.0	298.6	80.0	78.6
ARMS260-M1-SR07, -SR13	329.0	348.6	80.0	128.6
ARMS260-M2-SR02, -SR09	250.0	269.6	100.0	28.6
ARMS260-M2-SR04, -SR11	250.0	269.6	100.0	28.6
ARMS260-M2-SR06, -SR12	279.0	298.6	100.0	57.6
ARMS260-M2-SR07, -SR13	329.0	348.6	100.0	100.6

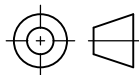

ARMS260-LD

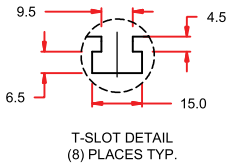
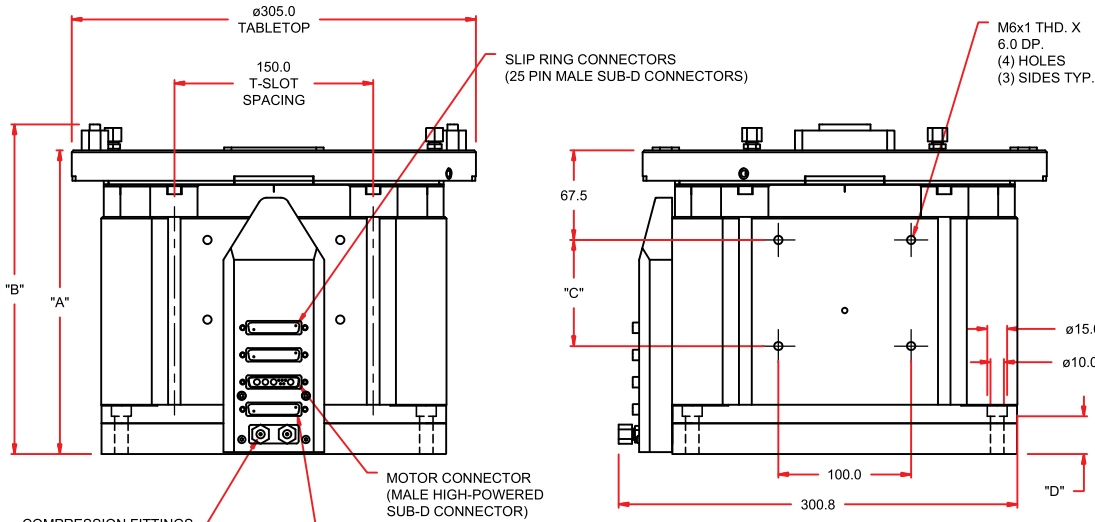
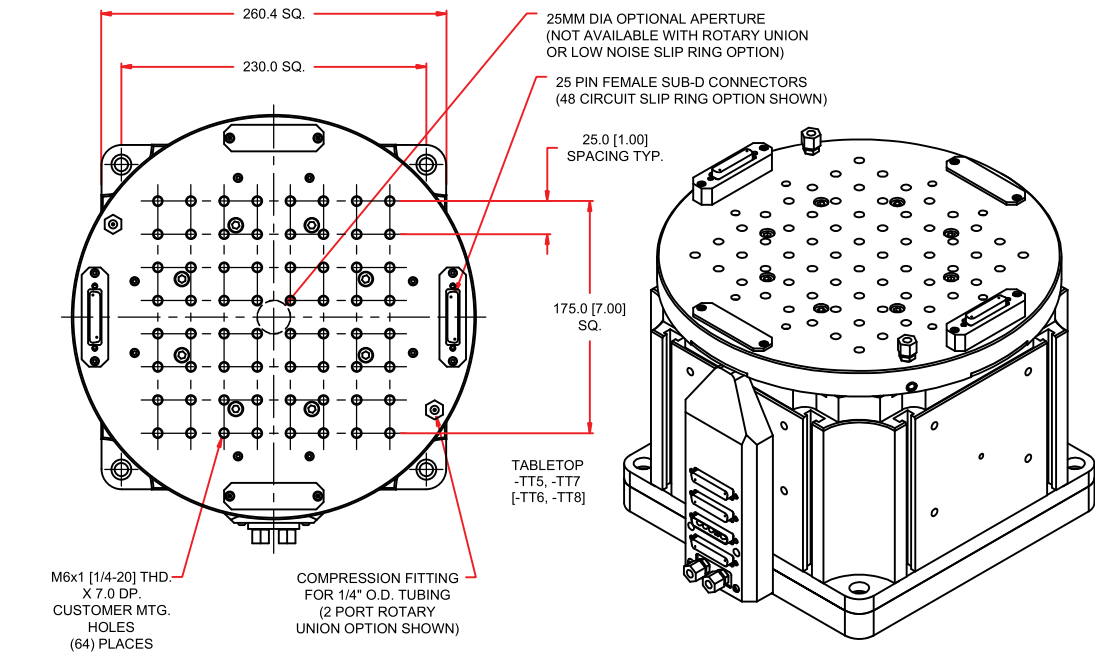

DIMENSIONS - MILLIMETERS				
BASIC MODEL	"A"	"B"	"C"	"D"
ARMS260-M1-SR02, -SR09	229.0	248.6	80.0	28.6
ARMS260-M1-SR04, -SR11	229.0	248.6	80.0	28.6
ARMS260-M1-SR06, -SR12	279.0	298.6	80.0	78.6
ARMS260-M1-SR07, -SR13	329.0	348.6	80.0	128.6
ARMS260-M2-SR02, -SR09	250.0	269.6	100.0	28.6
ARMS260-M2-SR04, -SR11	250.0	269.6	100.0	28.6
ARMS260-M2-SR06, -SR12	279.0	298.6	100.0	57.6
ARMS260-M2-SR07, -SR13	329.0	348.6	100.0	100.6

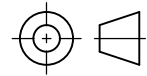

HPD260 DIMENSIONS

HPD260

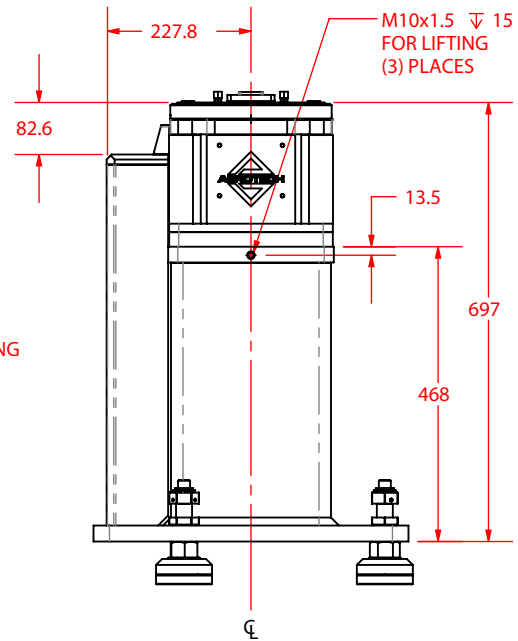
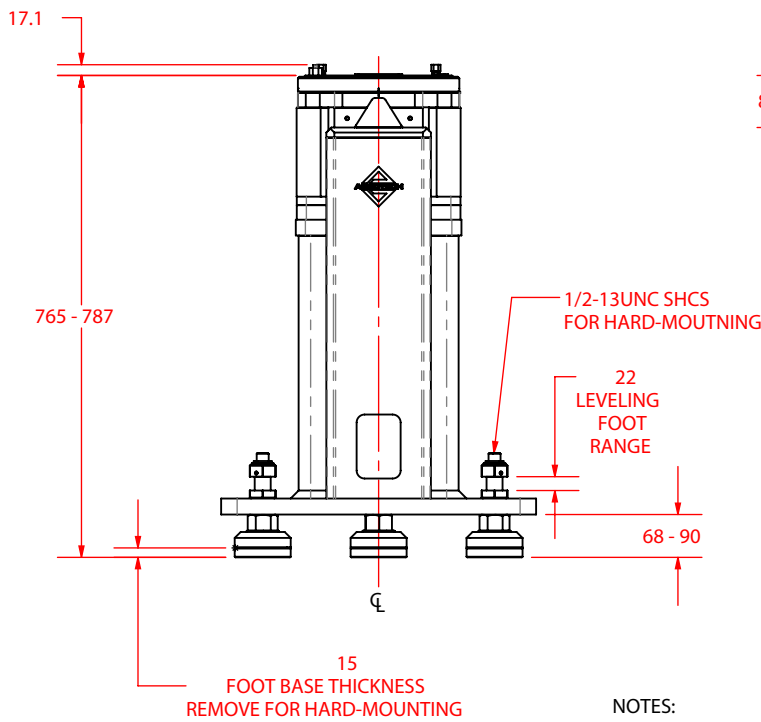
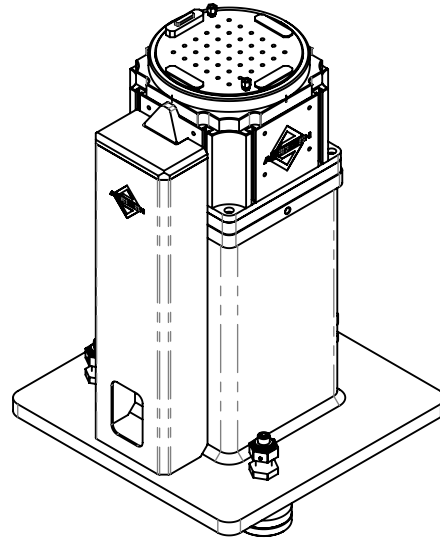
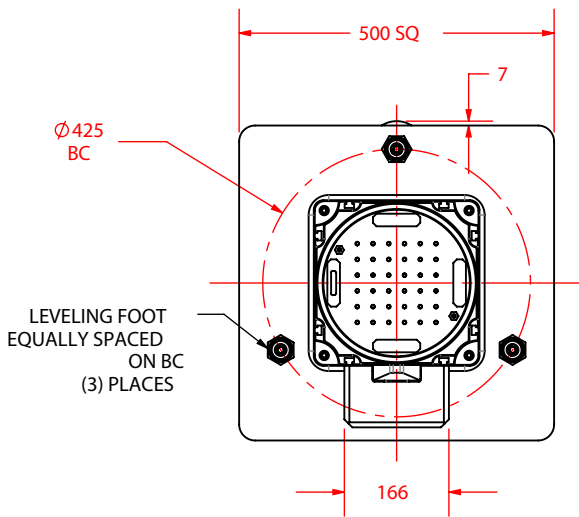

NOTES:

1. SEE ARMS260 DRAWING FOR STAGE DETAILS
2. HDP260 AS SHOWN IS CONFIGURED FOR -M1 MOTOR AND -SR1, -SR2, -SR5, -SR6 SLIP RING OPTIONS. CONSULT FACTORY FOR ALTERNATE CONFIGURATIONS.
3. ALL MOUNTING AND GRID PATTERNS AVAILABLE.
4. ALL ROTARY UNION OPTIONS AVAILABLE.

DIMENSIONS: MILLIMETERS

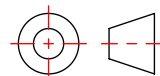

ARMS Series ORDERING INFORMATION

ARMS Rotary Motion Simulator

ARMS150	Rotary motion simulator
ARMS200	Rotary motion simulator
ARMS260	Rotary motion simulator

Tabletop (Required)

-TT1	Tabletop, metric dimension mounting, engraved scale
-TT2	Tabletop, English dimension mounting, engraved scale
-TT3	Tabletop, aperture, metric dimension mounting, engraved scale
-TT4	Tabletop, aperture, English dimension mounting, engraved scale
-TT5	Large diameter tabletop, metric dimension mounting
-TT6	Large diameter tabletop with English dimension mounting
-TT7	Large diameter tabletop, aperture, metric dimension mounting
-TT8	Large diameter tabletop, aperture, English dimension mounting

Motor (Required)

-M1	Direct-drive brushless, slotless motor, standard torque
-M2	Direct-drive brushless, slotless motor, high torque

Slip-Ring (Required)

-SR01	Integrated slip ring, 12 lines, 2A max current (ARMS150 and ARMS200 only)
-SR02	Integrated slip ring, 24 lines, 2A max current
-SR03	Integrated slip ring, 36 lines, 2A max current (ARMS200 only)
-SR04	Integrated slip ring, 48 lines, 2A max current (ARMS260 only)
-SR05	Integrated slip ring, 56 lines, 2A max current (ARMS200 only)
-SR06	Integrated slip ring, 72 lines, 2A max current (ARMS260 only)
-SR07	Integrated slip ring, 96 lines, 2A max current (ARMS260 only)
-SR08	Integrated slip ring, low-noise, 12 lines, 1A max current (ARMS150 and ARMS200 only)
-SR09	Integrated slip ring, low-noise, 24 lines, 1A max current with ARMS150 and ARMS200; 2A max current with ARMS260
-SR10	Integrated slip ring, low-noise, 30 lines, 1A max current (ARMS200 only)
-SR11	Integrated slip ring, low-noise, 48 lines, 2A max current (ARMS260 only)
-SR12	Integrated slip ring, low-noise, 70 lines, 2A max current (ARMS260 only)
-SR13	Integrated slip ring, low-noise, 90 lines, 2A max current (ARMS260 only)

Note: Slip ring options -SR03, -SR05, and -SR08 thru -SR13 are incompatible with all aperture tabletop options (-TT3, -TT4, -TT7, -TT8).

Rotary Union (Optional)

-RU1	One (1) rotary union line for air, vacuum, or non-corrosive gas, 120 psi max
-RU2	Two (2) rotary union lines for air, vacuum, or non-corrosive gas, 120 psi max

Note: Rotary union options are incompatible with all aperture tabletop options (-TT3, -TT4, -TT7, -TT8). Rotary unions for carrying liquids will require customized design, potentially resulting in dimensional changes to the ARMS product. Contact Aerotech to inquire.

Mounting Pedestal (Optional)

-HDP	Mounting pedestal with adjustable, hard-mount capable leveling feet
------	---

Integration (Required)

Aerotech offers both standard and custom integration services to help you get your system fully operational as quickly as possible. The following standard integration options are available for this system. Please consult Aerotech if you are unsure what level of integration is required, or if you desire custom integration support with your system.

-TAS	Integration - Test as system Testing, integration, and documentation of a group of components as a complete system that will be used together (ex: drive, controller, and stage). This includes parameter file generation, system tuning, and documentation of the system configuration.
-TAC	Integration - Test as components Testing and integration of individual items as discrete components that ship together. This is typically used for spare parts, replacement parts, or items that will not be used together. These components may or may not be part of a larger system.

ARMS Series ORDERING INFORMATION

Accessories (to be ordered as separate line item)

MC-D15-F	Connector mate, 15-Pin D-sub female
MC-D15-M	Connector mate, 15-Pin D-sub male
MC-D25-F	Connector mate, 25-Pin D-sub female
MC-D25-M	Connector mate, 25-Pin D-sub male