

# ATS150 Series

## *Mechanical Bearing, Screw-Driven Linear Stage*

Long life linear motion guide bearing system

Ultra-fine resolution

Integral bellows waycovers

Low profile, compact design

Submicron accuracy

Optional high-accuracy linear encoder



The ATS150 series motor-driven linear stages provide the high resolution and repeatability required for semiconductor wafer testing and fabrication, automated microscope inspection systems, and precision micromachining applications.

### **Construction Features**

ATS150 series stages are machined from a special cast aluminum alloy to provide a high strength-to-weight ratio, and long-term stability. The base is a box design that provides exceptional stiffness and stability.

ATS150 series stages employ a precision-ground ball screw that is pre-loaded to eliminate backlash, and its nut has wipers to prevent contamination and maintain high accuracy throughout the life of the stage. High quality, pre-loaded duplex bearings are used to eliminate axial play.

All ATS150 series stages incorporate Linear Motion Guide (LMG) bearings to provide high load capability and high stiffness. The LMG design provides a compact stage with continuous carriage support over the entire travel and good cantilevered load capability. Integral wipers on the bearing trucks help ensure stage travel life. Highly accurate optical limit switches and end stops are also standard.

Integral bellows-type waycovers protect the drive and bearing system from contamination. Metal surfaces are protected with an attractive clear anodized finish. Both metric (standard) and English mounting and bolt-hole patterns are available.

### **Linear Encoder**

A precision noncontact linear encoder is an option. The encoder is mounted internal to the stage, protecting it from external contaminants and debris.

### **Motors and Drives**

Included with all ATS150 series stages are Aerotech's BMS series brushless rotary motors. This motor has all of the advantages of a brushless motor – high acceleration, no brushes to wear, and lower heating – yet has zero cogging for extremely smooth motion and accuracy.

Aerotech manufactures a wide range of matching drives and controls to provide a fully integrated and optimized motion solution.

# ATS150 Series SPECIFICATIONS

Basic Model		ATS150-100	ATS150-150	ATS150-200	ATS150-250	
Total Travel		100 mm (4 in)	150 mm (6 in)	200 mm (8 in)	250 mm (10 in)	
Drive System		Super Precision Ground Ball Screw/Brushless Servomotor (BMS60-A-D25-E1000H)				
Bus Voltage		Up to 160 VDC				
Continuous Current	A <sub>pk</sub>	Up to 2.3 A				
	A <sub>rms</sub>	Up to 1.6 A				
Feedback		Noncontact Rotary Encoder (1000 line)				
Resolution	2 mm/rev lead	0.5 μm (20 μin) @ 4000 steps/rev Motor Resolution				
	4 mm/rev lead	1.0 μm (40 μin) @ 4000 steps/rev Motor Resolution				
	LN Linear Encoder	0.001 μm - 0.2 μm (0.04 μin - 8.0 μin)	NA	NA	NA	
Maximum Travel Speed <sup>(1)</sup>	2 mm/rev lead	115 mm/s (4.5 in/s)				
	4 mm/rev lead	230 mm/s (9.0 in/s)				
Maximum Load <sup>(2)</sup>	Horizontal	45.0 kg (99.2 lb)				
	Vertical	25.0 kg (55.1 lb)				
	Side	25.0 kg (55.1 lb)				
Accuracy	Ball Screw	Calibrated <sup>(3)</sup>	±1.0 μm (±40 μin)			
		Standard	+2, -4 μm (+80, -160 μin)	+2, -5 μm (+80, -200 μin)	+2, -8 μm (+80, -320 μin)	+2, -10 μm (+80, -400 μin)
	LN	Calibrated <sup>(3)</sup>	±1.0 μm (±40 μin)		NA	NA
		Standard	±5.0 μm (±200 μin)		NA	NA
Repeatability (Bidirectional)	Ball Screw	Calibrated <sup>(3)</sup>	±0.5 μm (±20 μin)			
		Standard	±1.0 μm (±40 μin)			
	LN	±0.5 μm (±20 μin)		NA	NA	
Straightness and Flatness	Differential	HALSF	1 μm/25 mm (40 μin/in)			
		Standard	2 μm/25 mm (80 μin/in)			
	Maximum Deviation	HALSF	±1.0 μm (±40 μin)	±1.5 μm (±60 μin)	±2.0 μm (±80 μin)	±3.0 μm (±120 μin)
		Standard	±2.0 μm (±80 μin)	±3.0 μm (±120 μin)	±4.0 μm (±160 μin)	±5.0 μm (±200 μin)
Pitch and Yaw		8 arc sec	10 arc sec	12 arc sec	14 arc sec	
Nominal Stage Weight	Less Motor	6.2 kg	6.8 kg	6.9 kg	7.4 kg	
	With Motor	7.3 kg	7.9 kg	8.0 kg	8.5 kg	
Construction		Aluminum Body/Stage and Table; Clear Anodize Finish				

**Notes:**

- Excessive duty cycle may impact accuracy.
- Payload specifications are for single axis system and based on ball screw and bearing life of 2500 km (100 million inches) of travel.
- Available with Aerotech controllers.
- Specifications are for single-axis systems, measured 25 mm above the tabletop. Performance of multi-axis systems is payload and workpoint dependent. Consult factory for multi-axis or non-standard applications.

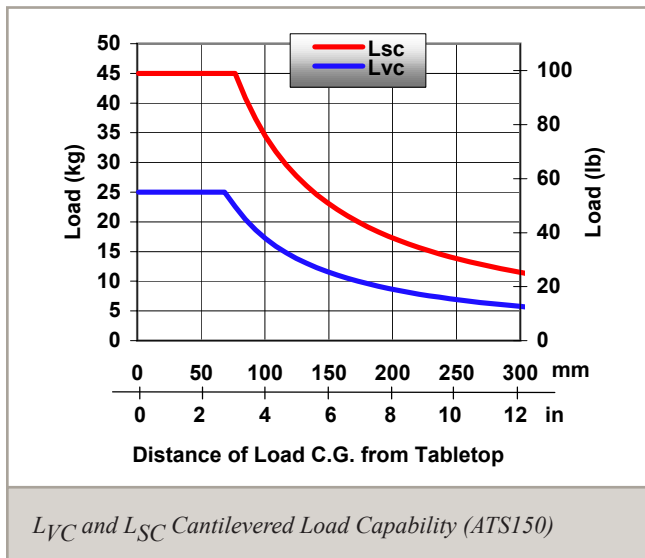

# ATS150 Series DIMENSIONS

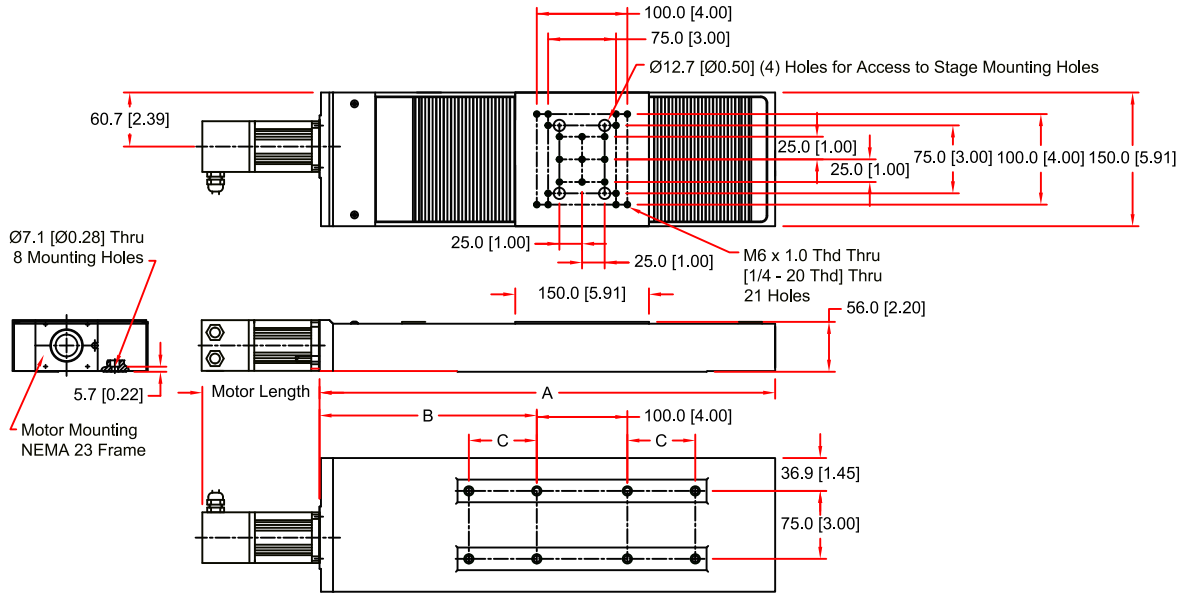

Dimensions - Millimeters [Inches]				
Basic Model	Total Travel	A	B	C
ATS150-100	100.0 [4.00]	411.2 [16.19]	193.8 [7.63]	-
ATS150-150	150.0 [6.00]	461.2 [18.16]	218.8 [8.61]	50.0 [2.00]
ATS150-200	200.0 [8.00]	511.2 [20.12]	243.8 [9.60]	75.0 [3.00]
ATS150-250	250.0 [10.00]	561.2 [22.09]	268.8 [10.58]	100.0 [4.00]

Motor Options	Length
-M1, -M3, -M5, -M7	132.3 [5.21]
-M2, -M4, -M6, -M8	209.5 [8.25]
-M9	110.9 [4.37]
-M10	111.9 [4.40]

ATS150 Series – HDZ2 Bracket DIMENSIONS

HDZ2 Bracket



HDZ2 Accommodates ATS150-100 and ATS150-150 Stages. For Right Angle Mounting of ATS150-200, -250 or -300, Please Consult Factory.

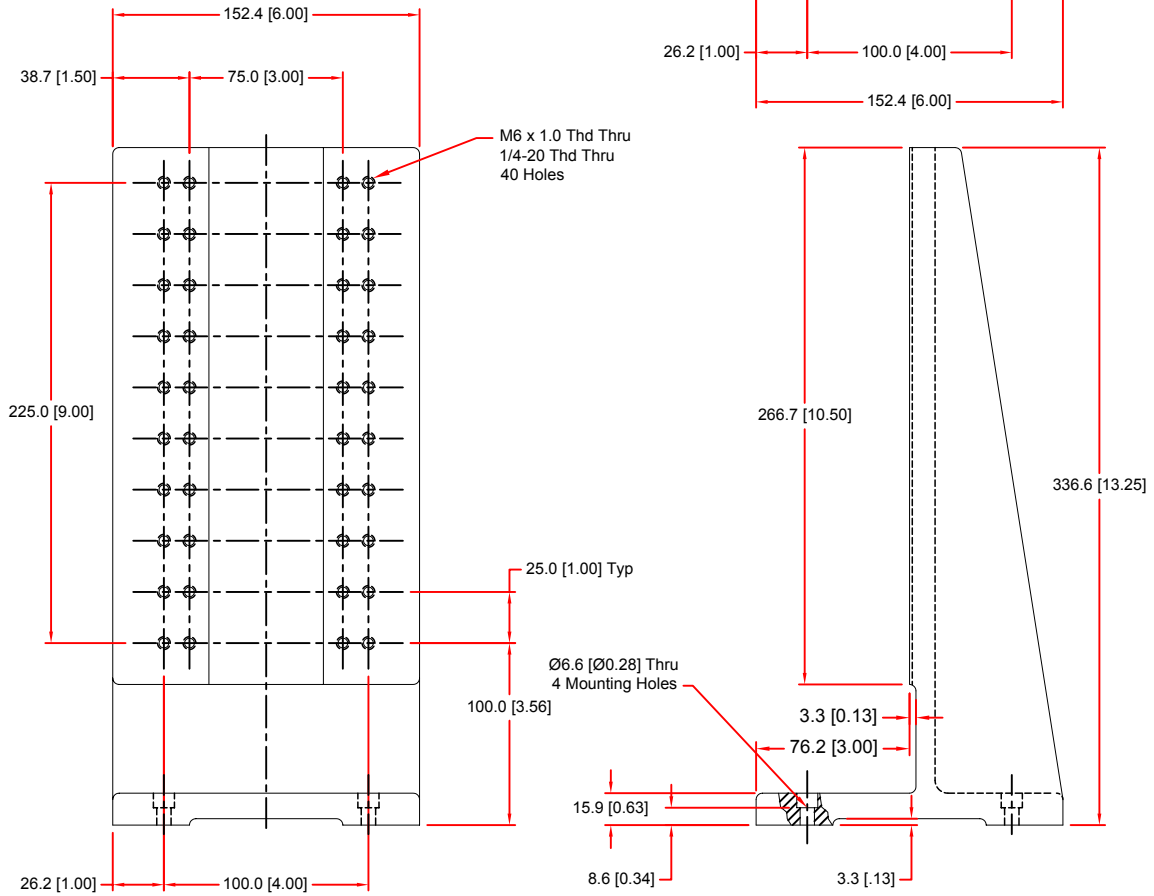

Dimensions - Millimeters [Inches]		
Basic Model	Recommended For Series	Weight kg [lb]
HDZ2	ATS150, ATS0200 & ATS1500	4.3 [9.5]

## ATS150 Series ORDERING INFORMATION

### Travel (Required)

-100	100 mm
-150	150 mm
-200	200 mm
-250	250 mm

### Vacuum Preparation (Optional)

-HV	High vacuum preparation to $10^{-6}$ Torr
-----	---

### Direct Linear Feedback (Optional)

-E1	High-accuracy incremental linear encoder; 1 Vpp
-----	---

Linear encoder option only available on the 100 mm and 150 mm travels.

### Tabletop (Required)

-TT1	Tabletop with metric dimension mounting pattern and holes
-TT2	Tabletop with English dimension mounting pattern and holes

### Ball Screw (Required)

-BS1	2 mm/rev precision-ground ball screw
-BS2	4 mm/rev precision-ground ball screw

### Motor (Optional)

-M1	BMS60 servomotor w/2500-line TTL encoder
-M2	BMS60 servomotor w/2500-line TTL encoder and holding brake
-M3	BMS60 servomotor w/1000-line 1 Vpp encoder
-M4	BMS60 servomotor w/1000-line 1 Vpp encoder and holding brake
-M5	BM75 servomotor w/2500-line TTL encoder
-M6	BM75 servomotor w/2500-line TTL encoder and holding brake
-M7	BM75 servomotor w/1000-line 1 Vpp encoder
-M8	BM75 servomotor w/1000-line 1 Vpp encoder and holding brake
-M9	SM60 stepper motor, SM60-CN1-VT2
-M10	SM60 stepper motor w/holding brake, SM60-CN1-VT2-BK

### Foldback (Optional)

-FB1	Foldback kit for .250 inch diameter shaft NEMA 23 motor
-FB2	Foldback kit w/brake for .250 inch diameter shaft NEMA 23 motor

### Motor Orientation (Optional)

-2	Bottom cable exit, optional orientation
-3	Left-side cable exit, standard orientation
-4	Top cable exit, optional orientation
-5	Right-side cable exit, optional orientation
-8	Right-side foldback, standard orientation
-12	Left-side foldback, optional orientation

### Limits (Required)

-LI1	Normally-closed limit switches, 9-pin D connector
-LI2	Normally-closed limit switches, flying leads
-LI3	Normally-open limit switches, 9-pin D connector
-LI4	Normally-open limit switches, flying leads

### Coupling (Optional)

-CP1	Coupling for 0.250 inch diameter shaft
-CP2	Coupling for 0.375 inch diameter shaft

## ATS150 Series ORDERING INFORMATION

### Metrology (Optional)

---

-PL1	Metrology, uncalibrated with performance plots
-PL2	Metrology, calibrated (HALAR) with performance plots

### Metrology - HALSF (Optional)

---

-PL5	Metrology, horizontal/vertical straightness correction (HALSF)
------	--

### Integration (Required)

Aerotech offers both standard and custom integration services to help you get your system fully operational as quickly as possible. The following standard integration options are available for this system. Please consult Aerotech if you are unsure what level of integration is required, or if you desire custom integration support with your system.

-TAS	<p>Integration - Test as system</p> <p>Testing, integration, and documentation of a group of components as a complete system that will be used together (ex: drive, controller, and stage). This includes parameter file generation, system tuning, and documentation of the system configuration.</p>
-TAC	<p>Integration - Test as components</p> <p>Testing and integration of individual items as discrete components that ship together. This is typically used for spare parts, replacement parts, or items that will not be used together. These components may or may not be part of a larger system.</p>

### Accessories (to be ordered as a separate line item)

---

ALIGN-NPA	Non-precision XY assembly
ALIGN-NPAZ	Non-precision XZ or YZ assembly
ALIGN-PA10	XY assembly; 10 arc sec orthogonality. Alignment to within 7 microns orthogonality for short travel stages.
ALIGN-PA10Z	XZ or YZ assembly with L-bracket; 10 arc second orthogonality. Alignment to within 10 microns orthogonality for short travel stages.
ALIGN-PA5	XY assembly; 5 arc sec orthogonality. Alignment to within 3 microns orthogonality for short travel stages.
ALIGN-PA5Z	XZ or YZ assembly with L-bracket; 5 arc second orthogonality. Alignment to within 5 microns orthogonality for short travel stages.
HDZ2	English right angle L-bracket; for ATS150-100 and ATS150-150 only
HDZ2M	Metric right angle L-bracket; for ATS150-100 and ATS150-150 only