

LARGE-APERTURE ROTARY STAGES **ALAR-LP SERIES**

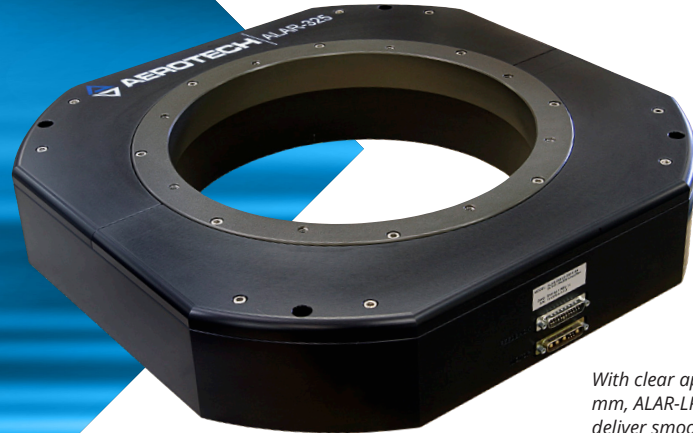

With clear apertures up to 325 mm, ALAR-LP direct-drive stages deliver smooth, precise rotation with a low-profile form factor.

Aerotech's ALAR family of direct-drive rotary stages provides superior angular positioning and velocity control. ALAR-LP (low profile) offers a generous payload capacity with a short overall height, making it ideal for space- or weight-constrained applications that require a vertical axis of rotation. Other members of the ALAR family include the ALAR-SP, which offers a balance of load capability, torque, and form factor, and the ALAR-XP, which delivers the highest levels of torque.

Advantage: ALAR

ALAR-LP offers numerous advantages over worm-drive stages. Because ALAR stages use direct-drive torque motors, they are free from backlash, vibration, and excessive wear commonly associated with gear-driven stages, and they are also capable of much higher speeds and accelerations. These advantages translate to higher system accuracy, repeatability, and longevity, as well as greater throughput. Users can more precisely manufacture, inspect, or process more parts in less time, leading to lower operating costs and higher profits.

Brushless, Slotless Direct-Drive Motors

Aerotech's brushless, direct-drive motors are featured in all ALAR

stages. Because there are neither brushes to wear, nor gear trains or couplings to maintain, ALAR stages are capable of high speeds and accelerations, plus consistent, stable performance over time with zero backlash, windup, or hysteresis. Further, ALAR motors are both slotless and ironless, thereby eliminating cogging and torque ripple to deliver exceptionally smooth motion. ALAR stages are ideal for applications requiring outstanding contoured motion, smooth scan velocities, and precise incremental steps.

Generous Payload Capacity with a Low Profile

Large-diameter angular contact bearings provide high axial- and radial-load capacities, maximizing positioning performance with respect to axis error motions, stiffness, and rotating friction. ALAR-LP is up to 40% shorter and up to 50% lighter than ALAR-SP, making this low-profile stage attractive in space- and weight-constrained applications. ALAR-LP performs best when oriented with a vertical axis of rotation.

Flexible Configurations for Simplified Integration

ALAR-LP is offered with features and options that facilitate easy integration into multi-axis motion systems and subsystems. It is available with a range of clear aperture diameters from 100



ALAR-LP is available in five aperture sizes ranging in diameter from 100 mm to 325 mm.

— PRODUCT HIGHLIGHTS —

Low-profile form factor with overall stage height as short as 65 mm

Direct-drive torque motor delivers extremely precise, smooth, cog-free rotation

Generous axial- and radial-load capacity is suitable for linear/rotary stage combinations and certain gimbals configurations

Long service life and consistent performance over time

Engineered for easy integration into multi-axis systems and machines

mm to 325 mm, and also a variety of feedback options including analog 1 Vpp, digital RS422, and absolute encoders. Continuous 360-degree travel is standard, with available limited-travel options ranging from 10 degrees to 340 degrees. ALAR-LP stages can even be adapted for use in vacuum environments.

Applications

Common applications for ALAR-LP stages include single- and multi-axis sensor testing, missile seeker testing, antenna testing, inertial navigation device testing, photonic component alignment,

high-accuracy laser machining, and precision wafer inspection. Due to their shorter height and lower mass, ALAR-LP stages are well-suited for linear/rotary stage combinations, and they can also be used as the azimuth axis in gimbal arrangements. The large-diameter clear aperture and direct-drive motor make ALAR a better-performing alternative to more traditional worm-gear stages, especially in dynamic applications with high payloads.

ALAR-LP Specifications

Mechanical Specifications	ALAR100LP	ALAR150LP	ALAR200LP	ALAR250LP	ALAR325LP
Travel	Continuous (optional 340° max. limited travel)				
Aperture	100 mm	150 mm	200 mm	250 mm	325 mm
Resolution (Min. Incremental Motion) ¹	0.1 μ rad (0.02 arc sec)	0.09 μ rad (0.018 arc sec)	0.02 μ rad (0.014 arc sec)	0.05 μ rad (0.01 arc sec)	0.04 μ rad (0.009 arc sec)
Accuracy ²	$\pm 9.7 \mu$ rad (± 2 arcsec)				
Bidirectional Repeatability	$\pm 2.4 \mu$ rad (± 0.5 arc sec)				
Tilt-Error Motion	19.4 μ rad (4.0 arc sec)				
Maximum Speed ³	50 rpm	45 rpm	90 rpm	90 rpm	120 rpm
Maximum Acceleration	1009 rad/s ²	829 rad/s ²	570 rad/s ²	407 rad/s ²	339 rad/s ²
Maximum Torque	17.5 N•m	22.9 N•m	126.8 N•m	147.9 N•m	213.8 N•m
Continuous Torque	3.0 N•m	4.0 N•m	19.3 N•m	22.5 N•m	35.0 N•m
Axial Load	1175 N	1325 N	4350 N	4590 N	5825 N
Radial Load	950 N	1275 N	4125 N	5050 N	6450 N
Moment Load ⁴	150 N•m	225 N•m	1075 N•m	1475 N•m	2200 N•m
Shaft Inertia	0.022 kg•m ²	0.031 kg•m ²	0.190 kg•m ²	0.310 kg•m ²	0.550 kg•m ²
Shaft Inertia with Limits	0.026 kg•m ²	0.042 kg•m ²	0.229 kg•m ²	0.383 kg•m ²	0.675 kg•m ²
Stage Mass	8.3 kg	9.8 kg	28.2 kg	35.0 kg	44.5 kg
Stage Mass with Limits	8.9 kg	10.8 kg	30.1 kg	37.4 kg	49.9 kg

1 Resolution assumes 1 Vpp encoder with 2000x controller multiplication.

2 Certified with each stage. Requires the use of an Aerotech controller.

3 Square-wave digital encoder options will limit maximum speed below the listed value. Contact factory for specific stage and encoder speed combination.

4 The ALAR-LP base must be fully supported by a rigid mounting surface to achieve the specified moment load.

Electrical Specifications	ALAR100LP	ALAR150LP	ALAR200LP	ALAR250LP	ALAR325LP
Motor	Brushless Slotless				
Continuous Current	A _{pk}	5.8	5.4	5.3	5.1
	A _{rms}	4.1	4.1	3.8	3.6
Peak Current, Stall	A _{pk}	33.5	31.4	34.8	31.2
	A _{rms}	23.7	22.2	24.6	22.1
Bus Voltage	Up to 340 VDC				
Incremental Encoder Line Count	31,488 lines/rev	36,000 lines/rev	47,200 lines/rev	55,040 lines/rev	64,800 lines/rev
Limit Switches ¹	5 V, normally closed				

1 Limited travel options only.

ALAR-LP Dimensions

ALAR100LP

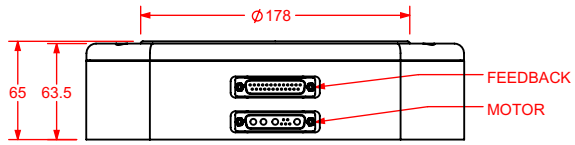
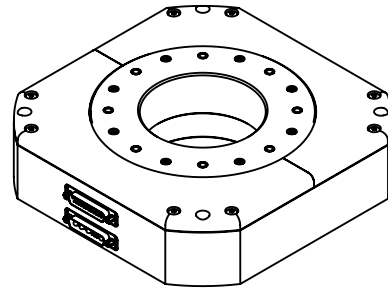
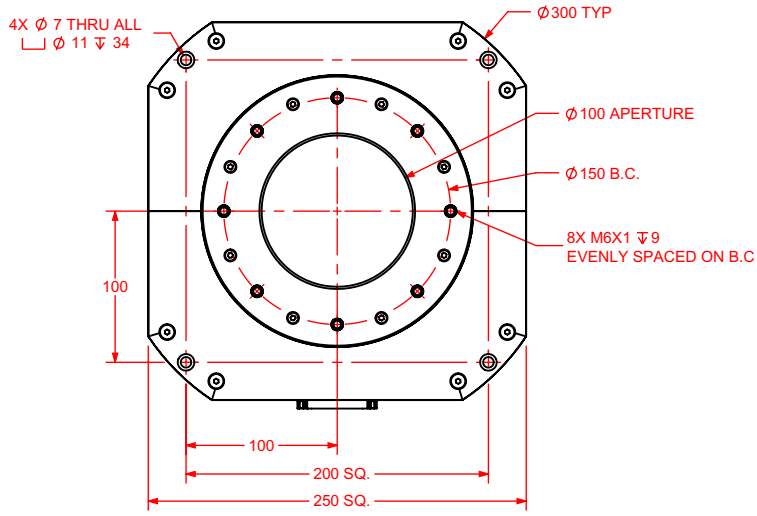

CONTINUOUS TRAVEL SHOWN

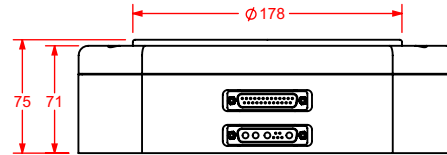

LIMITED TRAVEL (-TRXXX) SHOWN
(NOT A PROJECTED VIEW)

DIMENSIONS: MILLIMETERS

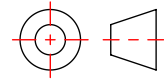

ALAR-LP Dimensions

ALAR150LP

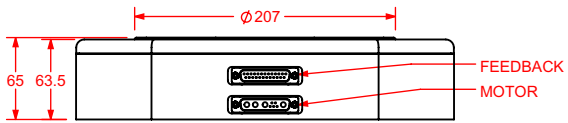
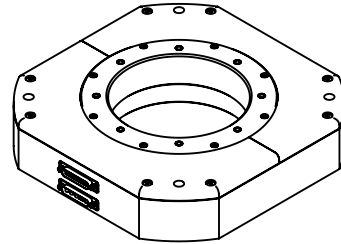
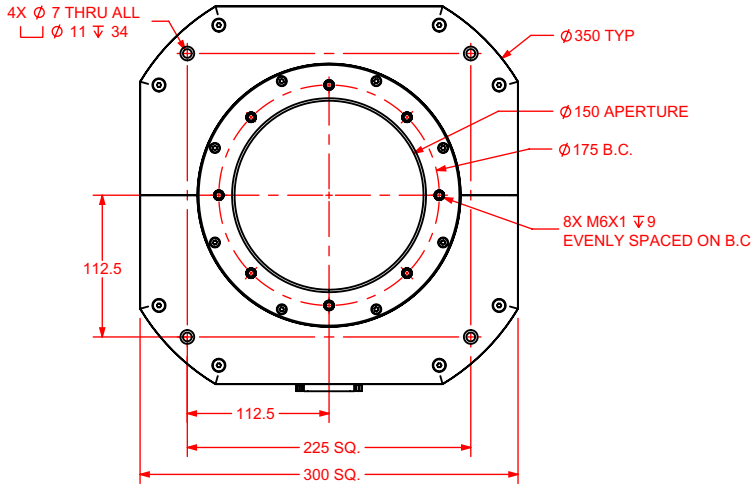

CONTINUOUS TRAVEL SHOWN

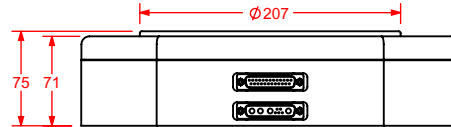

LIMITED TRAVEL (-TRXXX) SHOWN
 (NOT A PROJECTED VIEW)

DIMENSIONS: MILLIMETERS

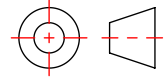

ALAR-LP Dimensions

ALAR200LP

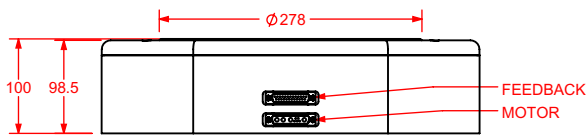
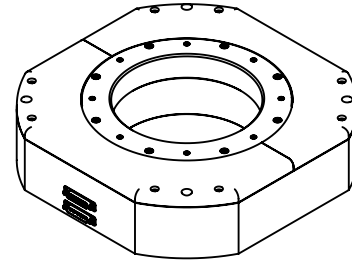
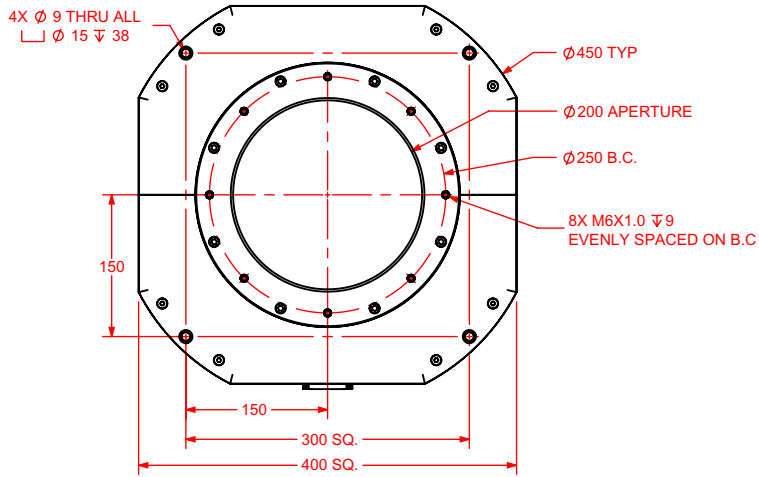

CONTINUOUS TRAVEL SHOWN

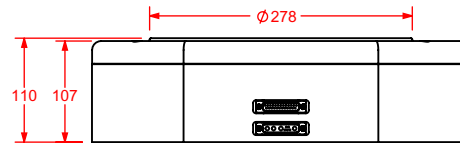

LIMITED TRAVEL (-TRXXX) SHOWN
 (NOT A PROJECTED VIEW)

DIMENSIONS: MILLIMETERS

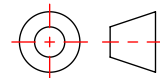

ALAR-LP Dimensions

ALAR250LP

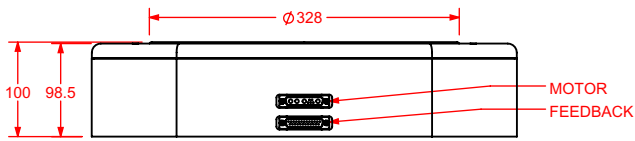
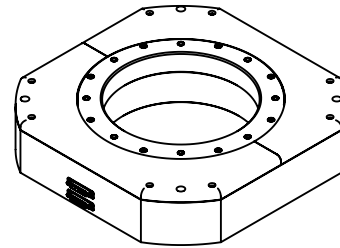
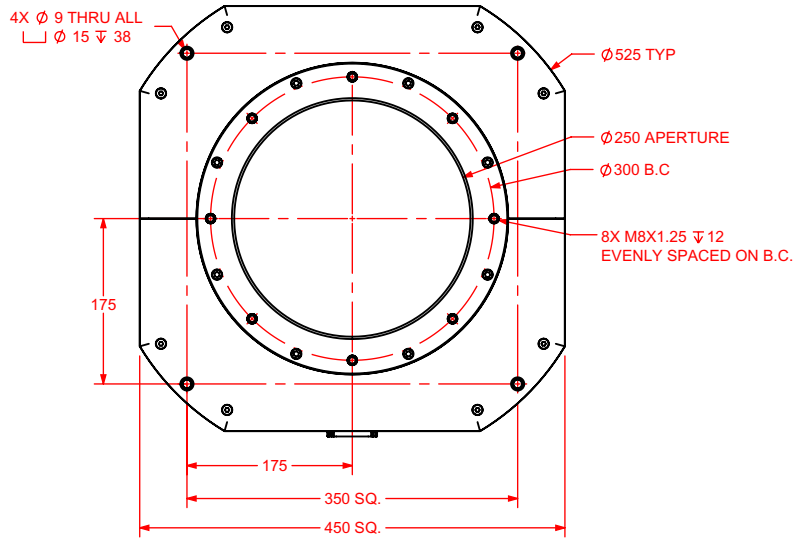

CONTINUOUS TRAVEL SHOWN

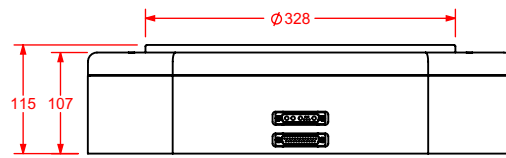

LIMITED TRAVEL (-TRXXX) SHOWN
 (NOT A PROJECTED VIEW)

DIMENSIONS: MILLIMETERS

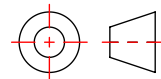

ALAR-LP Dimensions

ALAR325LP

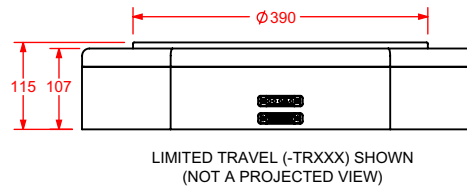
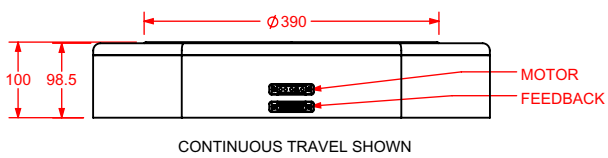
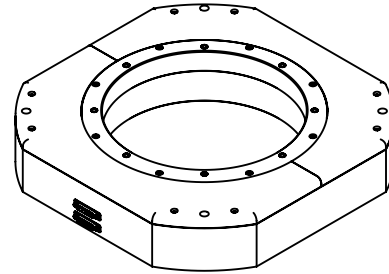
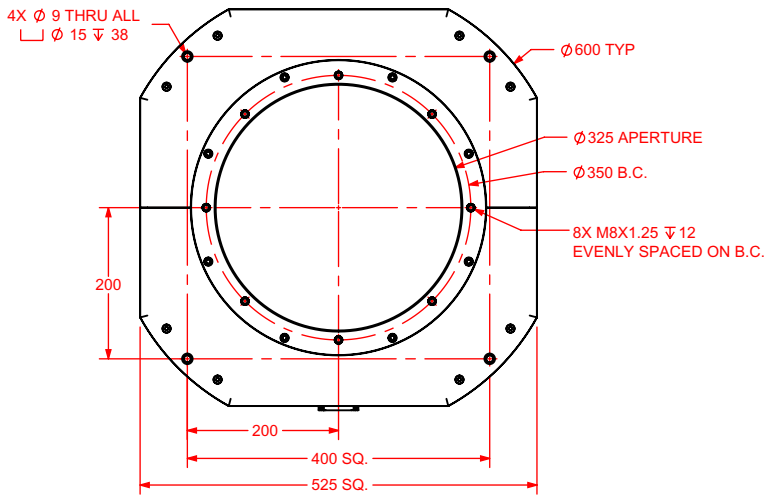

DIMENSIONS: MILLIMETERS

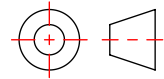

ALAR-LP Ordering Information

ALAR-LP Mechanical-Bearing Direct-Drive Rotary Stage

ALAR100LP	Mechanical-bearing, direct-drive rotary stage, low profile, 100 mm aperture
ALAR150LP	Mechanical-bearing, direct-drive rotary stage, low profile, 150 mm aperture
ALAR200LP	Mechanical-bearing, direct-drive rotary stage, low profile, 200 mm aperture
ALAR250LP	Mechanical-bearing, direct-drive rotary stage, low profile, 250 mm aperture
ALAR325LP	Mechanical-bearing, direct-drive rotary stage, low profile, 325 mm aperture

Travel (Required)

-	Continuous travel
-TR010	Limited travel, ± 5 degrees
-TR020	Limited travel, ± 10 degrees
-TR030	Limited travel, ± 15 degrees
-TR060	Limited travel, ± 30 degrees
-TR090	Limited travel, ± 45 degrees
-TR120	Limited travel, ± 60 degrees
-TR180	Limited travel, ± 90 degrees
-TR240	Limited travel, ± 120 degrees
-TR300	Limited travel, ± 150 degrees
-TR340	Limited travel, ± 170 degrees

Feedback (Required)

-E1	Incremental encoder, 1 Vpp
-E2	Incremental encoder, digital RS422, x4 interpolation
-E3	Incremental encoder, digital RS422, x20 interpolation
-E4	Incremental encoder, digital RS422, x40 interpolation
-E5	Incremental encoder, digital RS422, x100 interpolation
-E6	Incremental encoder, digital RS422, x200 interpolation
-E7	Absolute encoder

Integration (Required)

Aerotech offers both standard and custom integration services to help you get your system fully operational as quickly as possible. The following standard integration options are available for this system. Please consult Aerotech if you are unsure what level of integration is required, or if you desire custom integration support with your system.

-TAS	Integration - Test as system Testing, integration, and documentation of a group of components as a complete system that will be used together (ex: drive, controller, and stage). This includes parameter file generation, system tuning, and documentation of the system configuration.
-TAC	Integration - Test as components Testing and integration of individual items as discrete components. This is typically used for spare parts, replacement parts, or items that will not be used or shipped together (ex: stage only). These components may or may not be part of a larger system.