



# The Future Has Arrived

## Aerotech nano Motion Technology

Forty years ago there was a need by both the scientific community and the military aerospace companies for a manual adjusting mechanism to align and position test equipment with extremely high resolution over a large linear or angular range. This mechanism also had to have excellent long-term stability.

Aerotech filled that need with a novel product – the patented Coarse and Fine Adjustment and Positioning Mechanism (US Pat. No. 3,727,471). This large range and high resolution device was well-accepted and used by all of the leading research facilities. By incorporating this device Aerotech developed products with a linear resolution of 25 nanometers over 50 millimeters of travel, and sub-arc-second angular resolution over a large angular range. The Coarse and Fine Adjustment and Positioning Mechanism is still being used today.

In the ensuing years positioning and aligning requirements continued to grow, demanding ever higher performance in accuracy, speed, and resolution. Aerotech responded with novel, state-of-the-art technologies resulting in products with up to 1.5 meters travel length and submicron accuracy. These products broke productivity barriers by combining high speed and precision positioning for maximized throughput.

### High Throughput Nanopositioning

Our customers asked us to create equipment that would enable them to measure, manipulate, affect, and view sub-nanometer structures over a large area. To achieve that goal Aerotech had to advance the state-of-the art in high precision motion control.

Aerotech nano Motion Technology (AnMT) incorporates best-in-class electronic and magnetic circuits, unique feedback technology, dynamic trajectory management, application specific materials, and a powerful, easy-to-use control system. The result is a large selection of linear, rotary, and multi-axis positioning systems with nanometer and sub-arc-second resolution, super-high accuracies, and linear travel ranges from 25 to 160 millimeters and rotary travel ranges from 20 degrees to unlimited rotation.

These products are offered in three grades of accuracy – BASE, PLUS, and ULTRA – to enable our customers to select the right price/performance products for their specific application (see product specifications).

All AnMT products are calibrated and tested prior to shipment in our modern, environmentally controlled laboratory, utilizing the highest accuracy and resolution test equipment available today.

To assist you in selecting the right product for your application, please visit our website for more information or call any of our Sales Departments listed below for assistance.

#### WORLD HEADQUARTERS

##### Aerotech, Inc.

101 Zeta Drive  
Pittsburgh, PA 15238  
Ph: 412-963-7470  
Fax: 412-963-7459  
Email: sales@aerotech.com

##### Aerotech Germany

Gustav-Weißkopf-Str. 18  
90768 Fürth, Germany  
Ph: +49 (0)911 967 9370  
Fax: +49 (0)911 967 93720  
Email: sales@aerotechgmbh.de

##### Aerotech China

Room 101, No. 28 Building  
Tianlin Road 140  
Xuhui District  
Shanghai, China 200234  
Ph: +86 (21) 6126 1058  
Email: sales@aerotech.com

##### Aerotech Taiwan

5F, No 32, Aly 18, Ln 478  
Ruiguang Road  
Neihu District, Taipei City, 114  
Taiwan R.O.C.  
Ph: +886 (0)2 8751 6690  
Email: sales@aerotech.tw

##### Aerotech France

28300 Coltainville  
France  
Ph: +33 2 37 21 87 65  
Fax: +44 (0)1256 855649  
Email: cmonnier@aerotech.com

##### Aerotech United Kingdom

The Old Brick Kiln  
Ramsdell, Tadley  
Hampshire RG26 5PR  
United Kingdom  
Ph: +44 (0)1256 855055  
Fax: +44 (0)1256 855649  
Email: sales@aerotech.co.uk

##### Aerotech Japan

WBG Marive East 22F  
2-6-1 Nakase  
Mihama Ward, Chiba  
Japan 261-7122  
Ph: +81 (0)50 5830 6821  
Fax: +81 (0)43 306 3773  
Email: sales@aerotechhk.co.jp

Copyright © 2011, Aerotech, Inc. Information in this brochure is subject to change without notice.  
Ndrive® is a registered trademark of Aerotech.  
Npaq® is a registered trademark of Aerotech.

# Contents

---

## ADVANCED MECHATRONIC TECHNOLOGIES

Materials .....	4
Bearings.....	4
Magnetics.....	4
Feedback Devices .....	5
Electronics.....	6
Motion Controllers.....	7
Trajectory Generation .....	8
Software .....	8
System Test and Metrology .....	8
Dynamic Calibration Management System.....	8
System Checkout and Certification .....	9

## NANOPOSITIONING COMPONENTS

A Quick Look at our Nanopositioners .....	10
---	----

### Linear Stage Series

ANT95-L Direct-Drive Linear Stage (BASE and PLUS).....	14
ANT95-XY Dual-Axis Direct-Drive Linear Stage (BASE and PLUS).....	25
ANT95-XY-ULTRA Dual-Axis Direct-Drive Linear Stage with 2D Calibration.....	31

ANT130-L Direct-Drive Linear Stage (BASE and PLUS) .....	37
ANT130-XY Dual-Axis Direct-Drive Linear Stage (BASE and PLUS).....	44
ANT130-XY-ULTRA Dual-Axis Direct-Drive Linear Stage with 2D Calibration .....	51

### Rotary Stage Series

ANT95-R Direct-Drive Rotary Stage.....	57
ANT130-R Direct-Drive Rotary Stage .....	62

### "Z" Stage Series

ANT95-L-Z Direct-Drive Vertical "Z" Stage.....	67
ANT130-L-Z Direct-Drive Vertical "Z" Stage .....	73

### Vertical-Lift Stage Series

ANT95-3-V Linear Motor Wedge-Style Vertical Lift Stage.....	78
ANT130-5-V Linear Motor Wedge-Style Vertical Lift Stage .....	83

### Goniometer Series

ANT-20G Series.....	88
---------------------	----

## MOTION CONTROLLERS

Nano Motion Control Systems .....	96
Nano Motion Control System Components .....	98
Motion Composer.....	100
ML Linear Amplifiers .....	105
Npaq Drive Racks .....	108
Epaq and Epaq MR Controllers .....	113

## ABOUT AEROTECH

Aerotech at a Glance.....	120
Engineered Systems.....	122
Awards and Recognition.....	123
Capabilities in Other Markets .....	124
Aerotech Online.....	126
Worldwide Training and Support .....	127

# Advanced Mechatronic Technologies

## The Aerotech Competitive Edge – Total System Capability

### Introduction

To achieve the stated goals of high performance nanopositioning systems – long travel, high dynamic performance, high accuracy, high resolution, and easy-to-use software – Aerotech used its considerable experience acquired over 40 years in the field of mechanics, magnetics, electronics, computing, digital control systems, and electromechanical systems engineering to develop a line of products to meet the current and future requirements of the nanotechnology industries.

The following review of materials, bearings, magnetics, electronics, feedback devices, motion controllers, system and application software will assist potential users in the selection of the optimum combination of components and features for their specific application. This knowledge, complemented by Aerotech's engineering staff, will make possible the selection of the ultimate system configuration for each type of application.

### Mechanical System Consideration – Materials

Aerotech offers four types of materials with significantly different characteristics to satisfy the requirements of a particular application.

**Aluminum:** All of our aluminum stages are fabricated from thermally stable alloy to preserve their geometrical specification over their lifetime.

**Steel:** When the product is used in a less thermally stable environment over a long period of time, the use of steel is recommended.

**Ceramic:** To further improve stage dynamic performance in a thermally unstable environment, ceramic stage material is recommended. The ceramic stage mass is similar to aluminum, while the coefficient of expansion is slightly less than half, providing a more stable metrology environment over a longer period of time.

**INVAR:** If the cycle time is long and the thermal environment is uncertain, the use of INVAR is recommended for both the mechanics and feedback devices due to its nearly zero coefficient of expansion.

Each of these materials can be provided with different types of coatings. Because the selection of material and coating can significantly influence price and delivery, please consult your Aerotech Application Engineer for availability and price.

### Bearing Selections

Length of travel, dynamics, load, and friction considerations will all influence bearing selection. Aerotech offers four types of bearings: flexure, anti-creep crossed roller, linear motion guide, and air bearings.

Flexure bearings can be used for applications where travel is less than 1 mm, and loads are light ( $\ll 1$  kg). Flexure bearings provide highly repeatable, nearly hysteresis-free motion.

Crossed-roller bearings are used in stage designs that require precise motion and minimal disturbance from the bearing. They offer a compact footprint for short travels. Payloads are typically 0.5 kg to 50 kg. Practical travels are from 25 mm to 400 mm. Stage length and bearing cantilevering limit performance in longer travels. When coupled with an optimized motion system, these stages are capable of nanometer-level precision.

Stage designs that use linear motion guides range in travel from 25 mm to  $>3$  m. Payloads vary from 2 kg to  $>1000$  kg. Applications are usually point-to-point motion or contouring, where contouring dynamics are  $0.25 \mu\text{m}$  to  $1.0 \mu\text{m}$ . Linear motion guides are limited to 5-10 g acceleration and 5 m/s velocity.

Air-bearing stages provide nearly frictionless motion. Bearing geometric performance is superior to other bearing types. Practical travels are 25 mm to  $>3$  m, with payloads ranging from 1 kg to 250 kg. Bearing surfaces are relatively large compared to other bearing types, and stage size is comparatively large. Maximum speed is not limited by the bearing. The frictionless nature of these bearings enables the highest levels of accuracy and dynamic performance when compared to stage systems that use mechanical elements.

### Magnetics

To allow for high performance over long travels, Aerotech employs a noncontact, direct-drive motor technology. Aerotech's motor and magnetic design are optimized to minimize force ripple, maximize force, and minimize motor heating. Aerotech motors have higher power density than competing models. In addition, Aerotech's ability to customize motors to fit the stage allows for additional flexibility in the design.



# Advanced Mechatronic Technologies

## The Aerotech Competitive Edge – Optimum Feedback Technology

Device	Resolution	Thermal Stability	Travel
Encoder	<1 nm	High	Unlimited
Laser Interferometer	<1 nm	High	0 mm-2000 mm
Capacitance Probe <sup>(1)</sup>	<1 nm	High	<1 mm
LVDT <sup>(1)</sup>	>1 nm	Medium	0 mm-10 mm
Strain Gage <sup>(1)</sup>	>1 nm	Medium	<1 mm

Notes:

1. As the travel increases, so does the resolution and minimum step size.

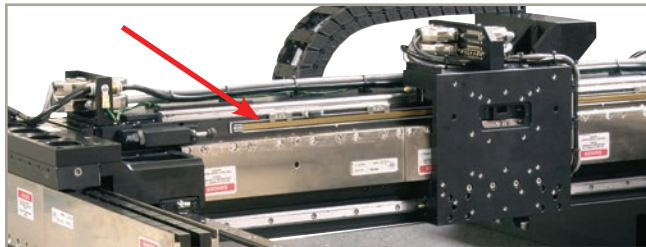

Figure 1. An example of a linear encoder in use.

### Feedback Devices

Aerotech offers a variety of feedback devices with its positioning systems. These include linear encoder, laser interferometer, capacitance probe, LVDT, and strain gage. The particular device chosen depends on the product and the application.

**Linear encoder:** Linear encoders employ a scale with a grating period and a read head (see Figure 1). The read head measures the gratings and generates an analog signal whose period is the same as the grating on the scale. Typical periods range from 200 nm to 20 μm. The output of the read head is either analog (1 volt peak-to-peak) or digital. Analog output is usually chosen as it gives the ability to have very

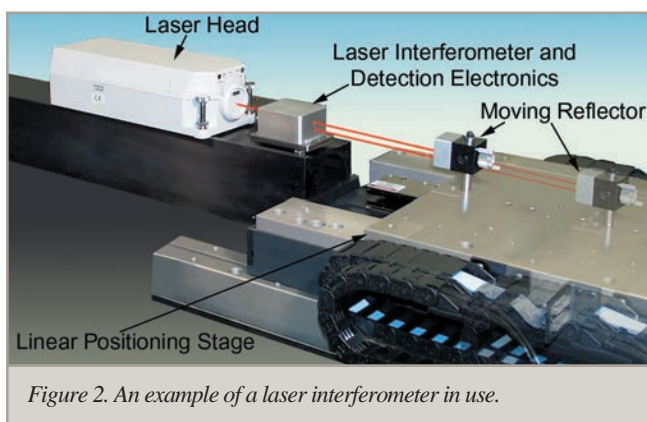

Figure 2. An example of a laser interferometer in use.

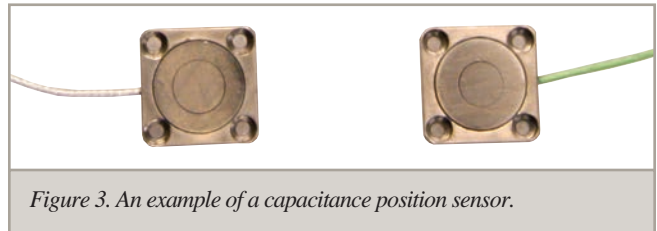

Figure 3. An example of a capacitance position sensor.

high resolution systems without sacrificing speed. In addition, various techniques are employed by Aerotech controllers to optimize the resolution and allow for exceptional in-position stability. Linear encoders are suitable for any travel.

**Laser Interferometer:** A laser interferometer feedback system requires a laser, optics, and processing unit (see Figure 2). A key advantage of the laser interferometer over other feedback devices is that it allows for measurement at the work point, as compared to other feedback devices that are usually mounted near the bearings. Work-point measurements greatly reduce the effects of Abbé offset errors. Laser interferometers are often used with environmental stations that allow for compensation due to external effects. However, they are expensive and require a clear beam path to the moving target. Laser interferometers are suitable for travels from 0 mm to 2000 mm.

**Capacitance Probe:** The capacitance probe is a type of dielectric sensor that uses capacitance to measure distance (see Figure 3). As the plates move closer to or further apart, the amount of charge accumulated on the plates changes. By measuring this charge, the relative change in distance between the two plates can be measured. While the probe itself is not too complex, the electronics required to disseminate the analog signal can be highly complex. Also, due to the low signal level, feedback signals from capacitance probes are more susceptible to electrical noise. Capacitance probe travel is typically limited to less than 1 mm in high-performance motion systems.

# Advanced Mechatronic Technologies

## The Aerotech Competitive Edge – Advanced Drive Components

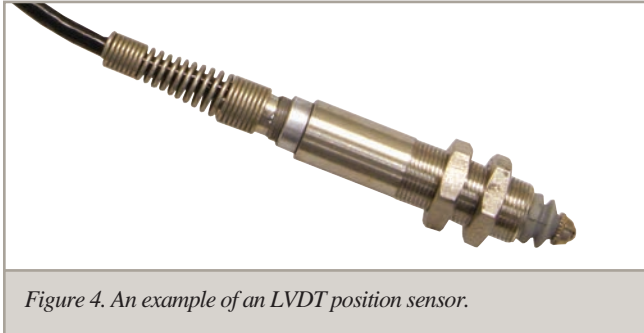

Figure 4. An example of an LVDT position sensor.

**LVDT:** An LVDT is a linear variable differential transformer (see Figure 4). As the magnetic core moves relative to the fixed windings, an output voltage is generated that is a function of the displacement. Advantages of these devices are small size and lower cost. They are typically used where travel is limited (<1 mm) and resolution requirements are on the order of tens of nanometers.

**Strain Gage:** The strain gage measures displacement by measuring the resistance change as the device (strain gage) deforms. The output signal is sampled by an A/D converter and converted to a displacement. To minimize thermal effects, a Wheatstone bridge is often connected to the unit under measurement. These devices are popular in short travel stages (<1 mm) due to the small size and low cost.

### Electronics

It is difficult to connect components from different suppliers and achieve the required specifications for high-performance systems. Aerotech understands the interaction between the various elements and designs control electronics to achieve the desired results.

When operating at the nanometer level, any disturbance on the system can lead to position errors. These disturbances can be external (ground floor, structural) or internal (noise on feedback signals, poor power electronics). Aerotech goes to great lengths to minimize self-induced electrical noise when designing the electronics. At a minimum the power amplifiers of the drive must be linear rather than the more common PWM (Pulse Width Modulated) amplifiers.

Compare the waveforms from PWM and linear amplifiers shown in Figures 5 and 6. Figure 5 shows an example of a PWM voltage and subsequent current for a sine wave. As can be seen from the figure, the voltage to the motor is a square wave. While inductance will filter this square wave, the

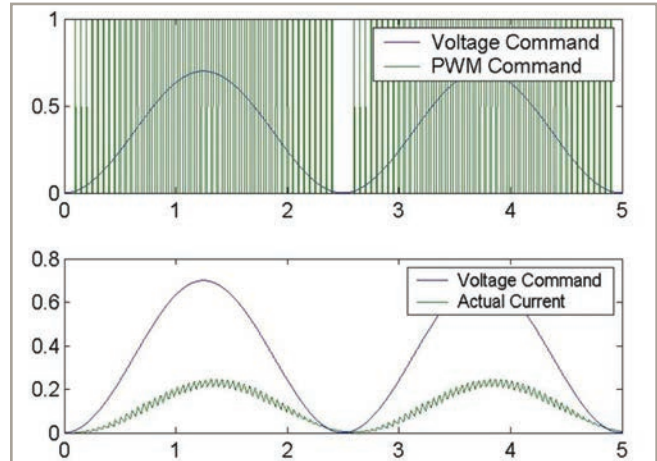

Figure 5. Output voltage and current from a PWM amplifier.

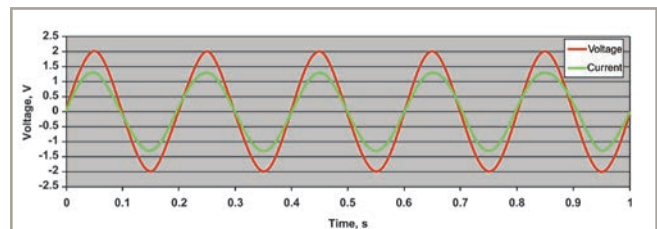

Figure 6. Output voltage and current from a linear amplifier.

resulting current will still contain a high-frequency component known as ripple current. When controlling systems with resolutions greater than 50 nm, the effect of this ripple current is negligible. When controlling systems with resolutions less than 50 nm, and more specifically, at resolutions less than 5 nm, the ripple can cause disturbances in the system. The end result is poor in-position stability.

Figure 6 shows the output voltage and current from a linear amplifier. As can be seen from this plot, the voltage and current waveform have no ripple current. Ultimately, this will lead to better in-position stability.

Linear amplifiers are not without their own inherent drawbacks. Due to their inefficiency, linear amplifiers are large and generate a significant amount of heat. Due to the transistor topology they can suffer from cross-over distortion. Cross-over distortion occurs when the current/voltage move through 0. Instead of the voltage/current having a smooth transition, a discontinuity occurs that can cause problems for the servo loop as it tries to hold the stage in position.

# Advanced Mechatronic Technologies

## The Aerotech Competitive Edge – Superior Software

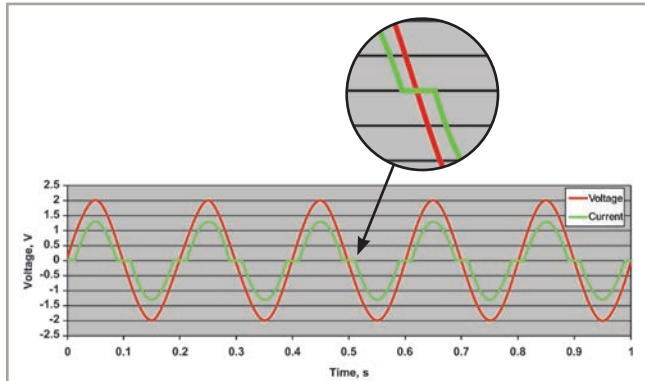

Figure 7. Cross-over instability in a linear amplifier.

Assuming no external disturbance on the system, the amount of force, and hence current, needed to hold position will be low. This means that the current will be in the cross-over distortion zone which makes it difficult for the servo system to maintain stability. Figure 7 shows this situation. Many currently available linear power amplifiers have this problem, but Aerotech has eliminated cross-over instability in our linear amplifiers, as can be seen from Figure 8.

Aerotech electronics support the different feedback devices mentioned. Because all of these feedback devices are inherently analog, there is some amount of noise on the signals. Of great importance is the ability of the control electronics to remove the unwanted noise and operate on the true signal. Aerotech has spent significant R&D on the development of electronics to optimize the data from the feedback devices.

### Motion Controllers

The Aerotech controller family offers high performance and flexibility that is easy to set up and use. Applications requiring coordinated motion (up to 32 axes) for both nano stages and other support axes, as well as single-axis nano motion controllers, are easily satisfied. The software-based A3200 combines PC technologies with the latest in real-time motion control for easy integration of other applications such as vision, data processing, and custom HMI's. Aerotech's stand-alone platforms, Ensemble and Soloist, offer the same high-performance motion and tools without requiring a Windows® PC. All of the controllers will run brushless, brush, voice coil, or stepper motors as well as using both PWM and/or linear drive technology. For the A3200 controller, the processing power is distributed across each of the axis controllers and the PC with a serial motion bus to minimize cable management

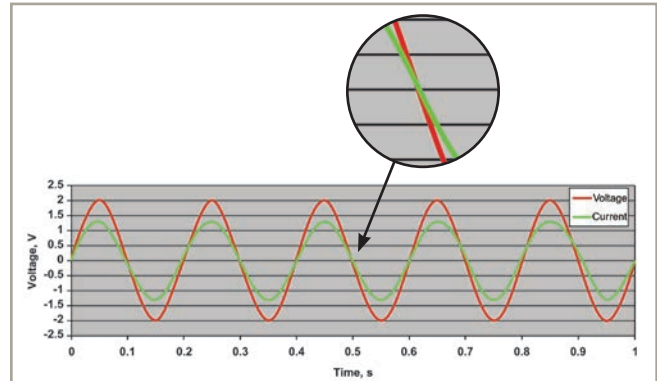

Figure 8. Aerotech linear amplifiers eliminate cross-over instability.

design and cost while providing consistent synchronization of each axis regardless of axis count. This distributed architecture also allows each axis to be optimally configured for drive technology, bus voltage, current, multiplier hardware, encoder technology, and I/O required – all configured through calculators for easy setup.

In addition to the 30-plus standard control features required by high-performance controllers, each of the controllers has advanced controller algorithms and hardware that minimize disturbance errors, increase tracking capabilities, and provide superior in-position stability. For instance, Harmonic Cancellation will learn the magnitude and frequency of repetitive motions and minimize the tracking error caused by the disturbances. Iterative Learning Control can be used to optimize repeating move sequences. The Enhanced Throughput Module (ETM) will increase machine throughput by measuring base motion and appropriately combining this with the servo loop. State-based Gain Scheduling and/or Friction Compensation can be used to increase servo performance with complex mechanical systems that change with load orientation. Position Synchronized Output (PSO) can trigger outputs based on the actual calibrated encoder position of 1, 2, or 3 axes during motion, even while accelerating, which increases machine throughput. Multi-axis firing with 200 ns latency at a rate of up to 10 MHz means more accurate measurements or processing of the associated laser, camera, and data acquisition. This advanced controls toolkit in conjunction with the other advanced Aerotech technologies can be combined to achieve true nanomotion, one nanometer at a time.

# Advanced Mechatronic Technologies

## The Aerotech Competitive Edge –

## Advanced Trajectory Management & Metrology

### Trajectory Generation

Aerotech's trajectory generator distributes the computation across the axes yielding more time for user programs to execute. The position, velocity, and acceleration are calculated and streamed to the axis controller every 125  $\mu$ s. Each new trajectory can be velocity blended or set a new endpoint for the motion. At the lowest level of trajectory generation a seven segment acceleration profile can be employed to precisely control the acceleration/deceleration of each move, even asymmetrically if necessary. Advanced trajectory commands, such as the slice command, increase the machine throughput and ease programming by optimally blending a step and scan into a single contoured move. Traditional soft-limits and safe zones are adhered to by the generator.

For users that prefer graphical programming, Aerotech's Motion Designer can be used to build any trajectory from basic building blocks – trapezoidal, sinusoidal, triangular, etc. – or just import actual data. Motion Designer will calculate the missing state information, filters can be added to smooth noise, and a program will be auto-generated and compiled that will run on any Aerotech controller.

### Software

Aerotech's Motion Composer Suite for the Aerotech A3200, Ensemble, and Soloist controllers focuses on ease-of-use for the user. Many of the common configurations are set up through calculators. The programmer will shorten development times compared with other controllers due to the Integrated Development Environment (IDE) that includes all of the standard and advanced tools for setup and debug. Additionally, Aerotech provides the flexibility to use the tools or controller most familiar to programmers. Complementing the IDE is a comprehensive .NET motion library that provides classes for motion, I/O, status, and diagnostic information. A programmer can program in Visual Studio and use the .NET library, or use the Motion Composer (IDE) to develop code with English style commands or G-code. A LabVIEW® .vi library is available for NI users. And for those using VB6, C++, or C, a complete C library and ASCII interface is available. The Motion Composer Suite includes the Motion Composer IDE, Digital Scope with many tools for time and frequency analysis, Configuration Manager for parameter and fault setting, Status Utility, and Operator's Interface. The Digital Scope collects and displays any signal in the controller. This provides users the tools to examine motion, inputs, and outputs of the process to optimize motion. Tools for time series analysis

(autotuning, min, max, rms) and frequency analysis (FFT, loop transmissions, bode plots) make setup easy. For instance, adding up to eight filters can be done by dragging the gain curve on a bode plot to the desired response. The filters will be automatically calculated and loaded into memory to achieve the goal. The integrated tools enable achieving optimal high performance nanomotion fast and easy.

### System Test and Metrology Capabilities

In order to achieve, measure, and certify the stated specification of the selected system, Aerotech made large investments over the years in its metrology and cleanroom capabilities. Our cleanroom not only meets the requirements of large system ISO 14644-1 Class 6 (Federal Standard 209E Class 1000) and cell specific ISO Class 5 (Class 100) capabilities, but also contains seismically isolated test areas that are temperature controlled to better than 0.25°C. When system test specifications do not require cleanroom capability, our other metrology laboratories (see <http://www.aerotech.com/clroom.html>) are utilized. These laboratories also have the capabilities to meet the environmental metrology requirements of nanotechnology and beyond.

To complement this large investment in our facilities, Aerotech also invested heavily in the required test equipment. State-of-the-art interferometers from Agilent, Renishaw and Zygo, phase measuring interferometers, capacitive position sensors, and LVDT transducers are used to verify, calibrate, and tune all of our linear systems.

For angular and geometrical measurement of rotary equipment, Moeller Wedel auto collimators combined with our Advanced Rotary Test Measurement System verify accuracy, resolution, axial and radial error motion and tilt error motion. This primary test system is supplemented by a host of other instrumentation: phase measuring interferometers, capacitance gages, LVDT transducers, optical flats, etc.

### Dynamic Calibration Management System

In order to achieve the highest possible system accuracy from our multi-axis nanopositioning systems, Aerotech has developed an industry-leading advanced, interactive, dynamic trajectory management system. To take advantage of this sophisticated interactive calibration system, the mechanical system has to be completely assembled and functionally tested prior to calibration in our best-in-class metrology labs. Nano-level system accuracy can only be achieved under stringent environmental conditions, calibrating

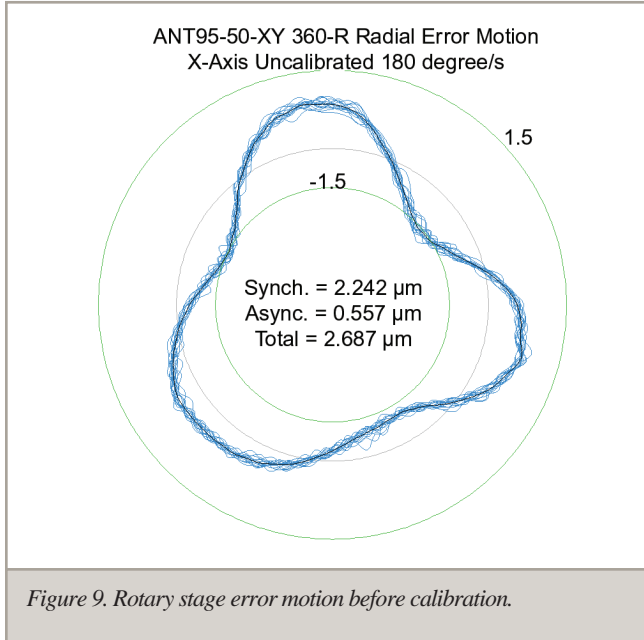

Figure 9. Rotary stage error motion before calibration.

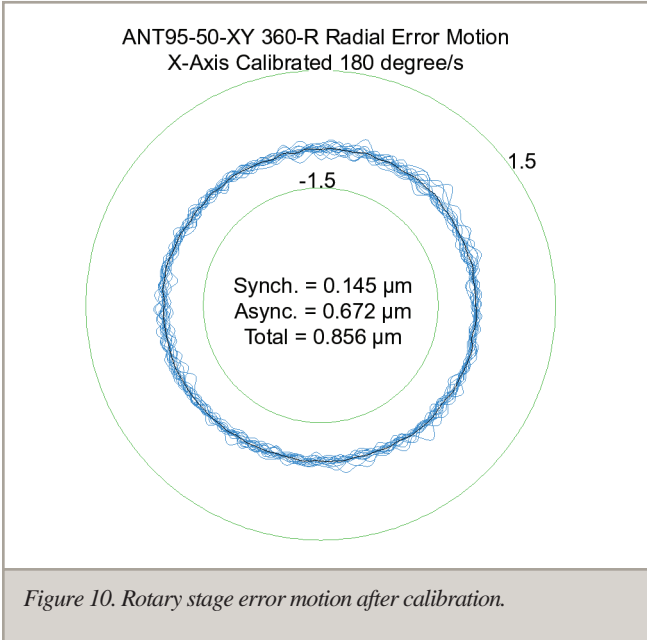

Figure 10. Rotary stage error motion after calibration.

with the best test equipment and utilizing the formidable capability of Aerotech’s Dynamic Calibration Management System.

An example can be seen in Figures 9 and 10. Figure 9 shows the error motion of a rotary stage mounted to an XY linear stage. Figure 10 shows the error motion after calibration. The synchronous error reduced by over 2 μm.

We invite you to visit us and witness our test and calibration procedures.

### System Checkout and Certification

Each system component is extensively tested and exercised prior to final system checkout. During final system checkout, each system is optimized per the customer’s requirements. The results of the testing and critical parameters are recorded, preserved, and shipped with the system. This data, and how it was obtained, is of utmost importance and serves as the Certification of Compliance. Aerotech will not permit any system to leave the premises unless it meets the stated specifications.



# A Quick Look at our Nanopositioners

Linear • Rotary • Vertical Lift and Z • Goniometer

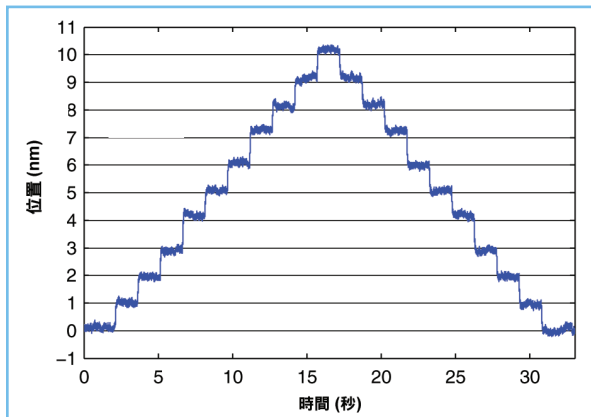

ANT95-50-L-PLUS 1 nm step plot



The ANT95-L series offers 25, 50, 75, or 100 mm travel.

## ANT95-L Single-Axis Linear Stage

Large travel

Noncontact, non-cogging, frictionless direct-drive – zero backlash or hysteresis

High resolution (1 nm) and accuracy (250 nm)

In-position stability of <1 nm

Anti-creep crossed-roller bearings

High dynamic performance

Available in X, XY, XYZ, and many other combinations

## ANT95-XY Dual-Axis Linear Stage

Large travel

Integrated low profile XY linear motor stage

Noncontact, non-cogging, frictionless direct-drive – zero backlash or hysteresis

High resolution (1 nm) and accuracy (250 nm)

In-position stability of <1 nm

Anti-creep crossed-roller bearings

High dynamic performance

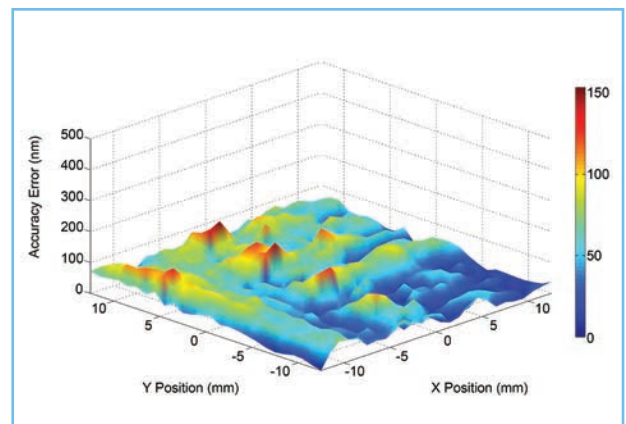

ANT95-XY PLUS 2D accuracy



The ANT95-XY series offers 25 x 25 mm or 50 x 50 mm travel.



The ANT130-L series offers 35, 60, 110, or 160 mm travel.

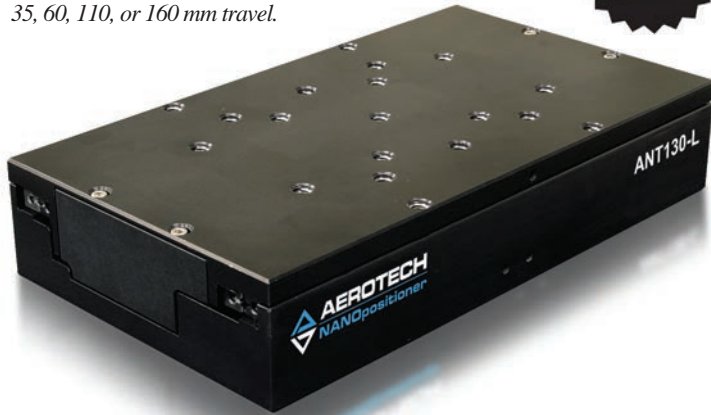

## ANT130-L Single-Axis Linear Stage

Large travel

Noncontact, non-cogging, frictionless direct-drive – zero backlash or hysteresis

High resolution (1 nm) and accuracy (250 nm)

Anti-creep crossed-roller bearings

High dynamic performance

Large selection – 4 different travel options

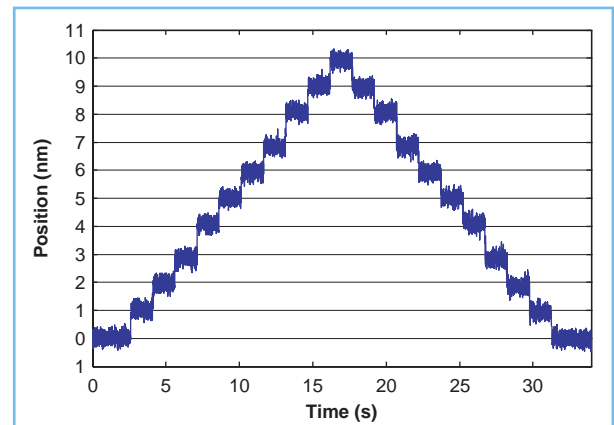

ANT130-060-L-PLUS 1 nm step plot

## ANT130-XY Dual-Axis Linear Stage

Large travel

Integrated, low profile, XY linear-motor stage

Noncontact, non-cogging, frictionless direct-drive – zero backlash or hysteresis

High resolution (1 nm) and accuracy (250 nm)

Anti-creep crossed-roller bearings

High dynamic performance

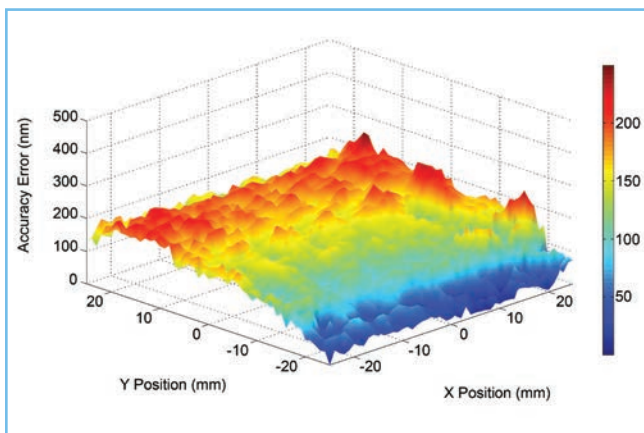

ANT130-XY PLUS 2D accuracy



The ANT130-XY series offers 60 x 60, 110 x 110, or 160 x 160 mm travel.

# A Quick Look at our Nanopositioners

Linear • Rotary • Vertical Lift and Z • Goniometer

## ANT95-R and ANT130-R Rotary Stages

High resolution (0.01 arc sec)

High performance;  
unlimited rotation

Outstanding error  
motion specifications

0.005 arc-second in-position  
stability

3 arc-second accuracy

1.5 arc-second bi-directional  
repeatability

Multi-axis configurations

*The ANT95-R series offers  
unlimited rotation.*

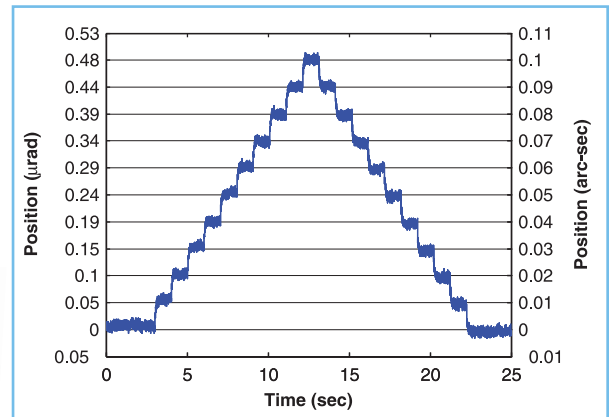

*ANT95-R-PLUS 0.01 arc-sec step plot*

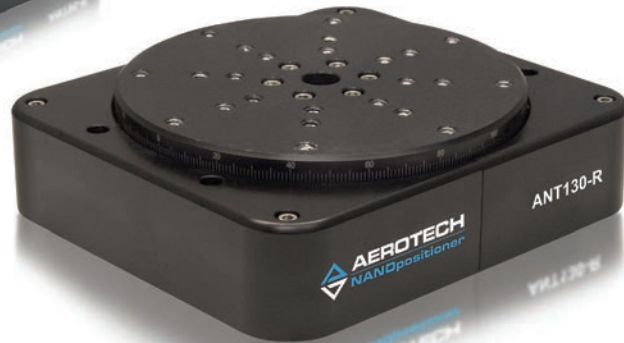

*The ANT130-R series offers  
unlimited rotation.*

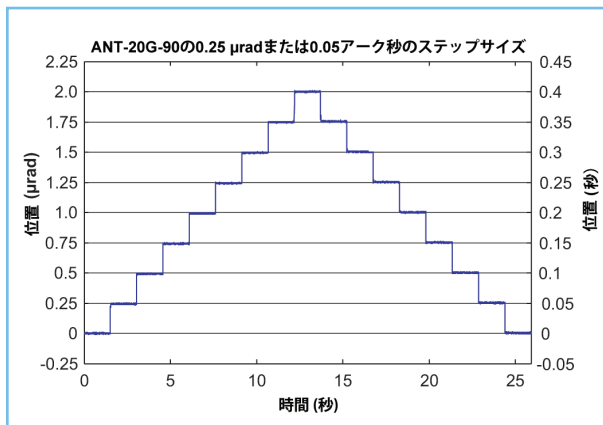

*ANT-20G-90 0.05 arc-sec step plot*

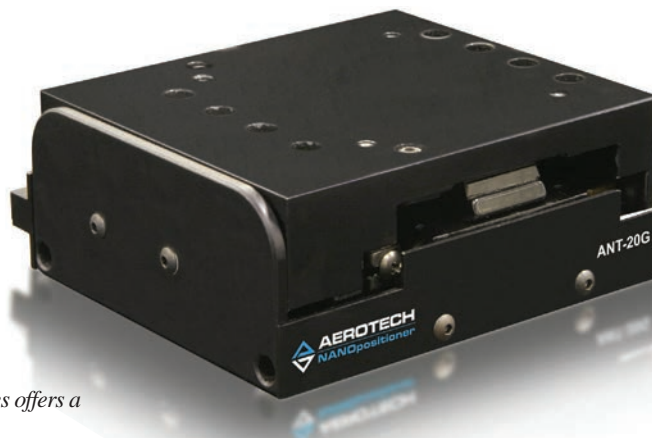

*The ANT-20G series offers a  
20° rotation angle.*

## ANT-20G Goniometers

Noncontact, non-cogging,  
frictionless direct-drive for  
zero backlash or hysteresis

High speed (150°/s)

High resolution (0.05 arc second)

Excellent in-position stability

Large rotation angle – 20°

Orthogonal mounting  
of two cradles provides  
rotation about the same point

No maintenance

Compact design

## ANT95-L-Z and ANT130-L-Z

Nanometer performance in a large travel format

High resolution (2 nm) and accuracy (300 nm)

In-position stability of <math><2\text{ nm}</math>

Anti-creep crossed-roller bearings

High dynamic performance



*ANT130-L-Z series offers 35 or 60 mm travel.*

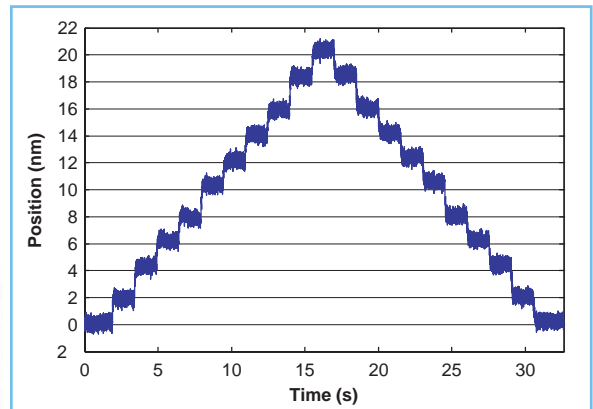

*ANT95-50-L-Z-PLUS 2 nm step plot*

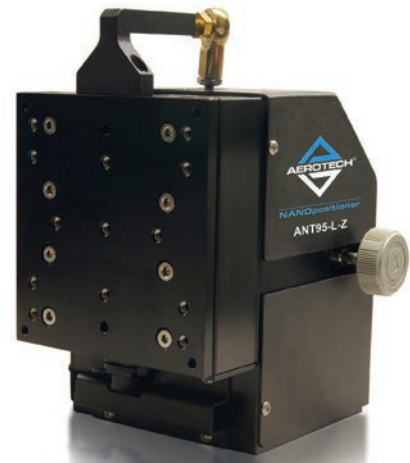

*The ANT95-L-Z series offers 25 or 50 mm travel.*

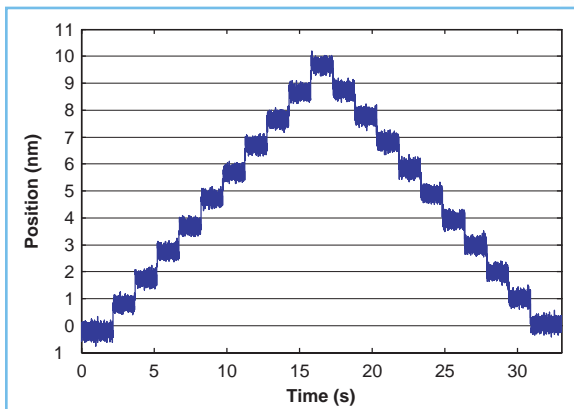

*ANT95-3-V-PLUS 1 nm step plot*

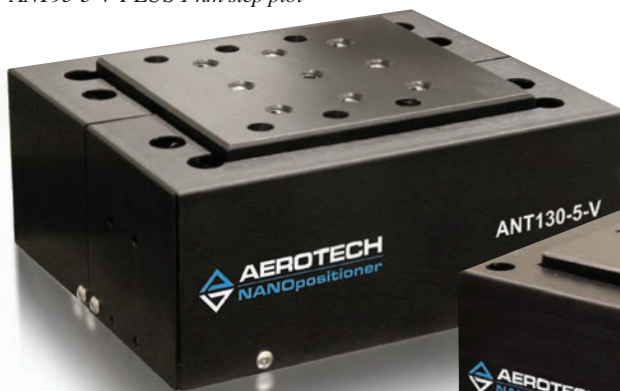

*The ANT130-5-V series offers 5 mm travel.*



*The ANT95-3-V series offers 3 mm travel.*

## ANT95-3-V and ANT130-5-V

Nanometer performance in a large travel format

In-position stability of <math><1\text{ nm}</math>

3 or 5 mm travel

200 nm accuracy

Anti-creep crossed-roller bearings

High dynamic performance

# ANT95-L Series

## Single-Axis Linear Direct-Drive Nanopositioning Stages

Nanometer-level performance in a large travel format

High resolution (1 nm), repeatability (75 nm), and accuracy (250 nm)

In-position stability of <1 nm

Anti-creep crossed-roller bearings

High dynamic performance

nano Motion Technology



### Introduction

Aerotech's ANT95 series stages are the world's first nanometer-level positioning systems with greater than 25 mm travel. The ANT95-L and ANT95-L-PLUS crossed-roller stages are the best-in-class in combining speed, accuracy, resolution, repeatability, reliability, and size, and are offered in two accuracy grades. As an evolution of the ANT stage family, these linear stages exhibit enhanced motion performance over Aerotech's first generation ANT series. Product improvements such as 5 g acceleration, 500 mm/s velocity, enhanced load capacity, and standardized, universal base mounting patterns allow the use of this flexible stage family in an even wider range of configurations than its predecessors.

### Noncontact Direct-Drive

All of the original ANT series' direct-drive advantages have been preserved in the ANT95-L family. Only noncontact direct-drive technology offers the robust, accurate, and high-speed positioning necessary for mass production of precision devices. ANT95-L stages utilize advanced direct-drive technology pioneered by Aerotech to achieve the highest level of positioning performance. This direct-drive technology is high-performance, non-cogging, noncontact, high-speed, high-resolution, and high-accuracy. This unique drive and bearing combination, packaged in an extremely small-profile and footprint, offers tangible advantages in many applications such as high-precision positioning, disk-drive fabrication, fiber alignment, optical delay element actuation, sensor testing, and scanning processes that demand smooth and precise motion.

### Flexible System Design

The ANT95-L family has universal mounting and tabletop patterns that allow for easy system integration. Two, three, or more axes can be easily combined for flexible system designs and multi-axis configurations.

### System Characteristics

Outstanding accuracy, position repeatability, and in-position stability require high system resolution. The ANT95-L stage's industry-leading 1 nm minimum incremental step size provides this high level of performance. Aerotech's direct-drive technology has no hysteresis or backlash, enabling accurate and repeatable nanometer-scale motion.

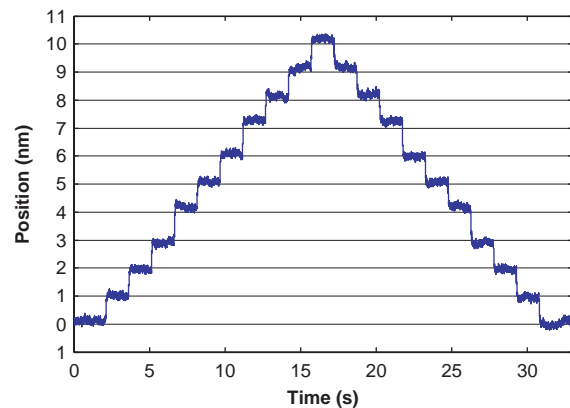

ANT95-50-L-PLUS 1 nm step plot. Best-in-class resolution and exceptional in-position stability for large travel stages.



## ANT95-L Series SPECIFICATIONS

Mechanical Specifications	ANT95-25-L	ANT95-25-L-PLUS	ANT95-50-L	ANT95-50-L-PLUS
Travel	25 mm	25 mm	50 mm	50 mm
Accuracy <sup>(1)</sup>	±2.5 µm (±100 µin)	±250 nm (±10 µin)	±2.5 µm (±100 µin)	±250 nm (±10 µin)
Resolution	1 nm (0.04 µin)	1 nm (0.04 µin)	1 nm (0.04 µin)	1 nm (0.04 µin)
Repeatability (Bi-Directional) <sup>(1)</sup>	±100 nm (±4 µin)	±75 nm (±3 µin)	±100 nm (±4 µin)	±75 nm (±3 µin)
Repeatability (Uni-Directional)	±25 nm (±1 µin)	±25 nm (±1 µin)	±25 nm (±1 µin)	±25 nm (±1 µin)
Straightness <sup>(1)</sup>	±1.0 µm (±40 µin)	±1.0 µm (±40 µin)	±1.0 µm (±40 µin)	±1.0 µm (±40 µin)
Flatness <sup>(1)</sup>	±1.0 µm (±40 µin)	±1.0 µm (±40 µin)	±1.0 µm (±40 µin)	±1.0 µm (±40 µin)
Pitch	10 arc sec	10 arc sec	10 arc sec	10 arc sec
Roll	10 arc sec	10 arc sec	10 arc sec	10 arc sec
Yaw	5 arc sec	5 arc sec	5 arc sec	5 arc sec
Maximum Speed	500 mm/s (20 in/s)	500 mm/s (20 in/s)	500 mm/s (20 in/s)	500 mm/s (20 in/s)
Maximum Acceleration	5 g - 50 m/s <sup>2</sup> (No Load)	5 g - 50 m/s <sup>2</sup> (No Load)	4 g - 40 m/s <sup>2</sup> (No Load)	4 g - 40 m/s <sup>2</sup> (No Load)
Speed Stability	See graph for typical performance			
Settling Time	See graph for typical performance			
In-Position Stability <sup>(2)</sup>	<1 nm (<0.04 µin)	<1 nm (<0.04 µin)	<1 nm (<0.04 µin)	<1 nm (<0.04 µin)
Maximum Force (Continuous)	7.75 N	7.75 N	9.5 N	9.5 N
Load Capacity <sup>(3)</sup>	Horizontal	5.0 kg (11 lb)	5.0 kg (11 lb)	7.0 kg (15.4 lb)
	Side	5.0 kg (11 lb)	5.0 kg (11 lb)	5.0 kg (11 lb)
Moving Mass	0.46 kg (1.0 lb)	0.46 kg (1.0 lb)	0.52 kg (1.1 lb)	0.52 kg (1.1 lb)
Stage Mass	0.8 kg (1.8 lb)	0.8 kg (1.8 lb)	1.2 kg (2.7 lb)	1.2 kg (2.7 lb)
Material	Aluminum Body/Black Hardcoat Finish			
MTBF (Mean Time Between Failure)	30,000 Hours			

Notes:

1. Certified with each stage.

2. In-Position Jitter listing is 3 sigma value.

3. Axis orientation for on-axis loading is listed.

• Specifications are for single-axis systems measured 25 mm above the tabletop. Performance of combined multi-axis systems is payload and workpoint dependent. Consult factory for multi-axis or non-standard applications.

• -PLUS requires the use of an Aerotech controller.

Mechanical Specifications	ANT95-75-L	ANT95-75-L-PLUS	ANT95-100-L	ANT95-100-L-PLUS
Travel	75 mm	75 mm	100 mm	100 mm
Accuracy <sup>(1)</sup>	±4.0 µm (±160 µin)	±275 nm (±11 µin)	±5.0 µm (±200 µin)	±275 nm (±11 µin)
Resolution	1 nm (0.04 µin)	1 nm (0.04 µin)	1 nm (0.04 µin)	1 nm (0.04 µin)
Repeatability (Bi-Directional) <sup>(1)</sup>	±100 nm (±4 µin)	±75 nm (±3 µin)	±100 nm (±4 µin)	±75 nm (±3 µin)
Repeatability (Uni-Directional)	±25 nm (±1 µin)	±25 nm (±1 µin)	±25 nm (±1 µin)	±25 nm (±1 µin)
Straightness <sup>(1)</sup>	±2.0 µm (±80 µin)	±2.0 µm (±80 µin)	±2.5 µm (±100 µin)	±2.5 µm (±100 µin)
Flatness <sup>(1)</sup>	±2.0 µm (±80 µin)	±2.0 µm (±80 µin)	±2.5 µm (±100 µin)	±2.5 µm (±100 µin)
Pitch	10 arc sec	10 arc sec	10 arc sec	10 arc sec
Roll	10 arc sec	10 arc sec	10 arc sec	10 arc sec
Yaw	5 arc sec	5 arc sec	5 arc sec	5 arc sec
Maximum Speed	500 mm/s (20 in/s)	500 mm/s (20 in/s)	500 mm/s (20 in/s)	500 mm/s (20 in/s)
Maximum Acceleration	3 g - 30 m/s <sup>2</sup> (No Load)	3 g - 30 m/s <sup>2</sup> (No Load)	3 g - 30 m/s <sup>2</sup> (No Load)	3 g - 30 m/s <sup>2</sup> (No Load)
Speed Stability	See graph for typical performance			
Settling Time	See graph for typical performance			
In-Position Stability <sup>(2)</sup>	<1 nm (<0.04 µin)	<1 nm (<0.04 µin)	<1 nm (<0.04 µin)	<1 nm (<0.04 µin)
Maximum Force (Continuous)	9.5 N	9.5 N	12.9 N	12.9 N
Load Capacity <sup>(3)</sup>	Horizontal	7.0 kg (15.4 lb)	7.0 kg (15.4 lb)	7.0 kg (15.4 lb)
	Side	5.0 kg (11 lb)	5.0 kg (11 lb)	5.0 kg (11 lb)
Moving Mass	0.72 kg (1.6 lb)	0.72 kg (1.6 lb)	0.91 kg (2.0 lb)	0.91 kg (2.0 lb)
Stage Mass	1.64 kg (3.6 lb)	1.64 kg (3.6 lb)	2.1 kg (4.6 lb)	2.1 kg (4.6 lb)
Material	Aluminum Body/Black Hardcoat Finish			
MTBF (Mean Time Between Failure)	30,000 Hours			

Notes:

1. Certified with each stage.

2. In-Position Jitter listing is 3 sigma value.

3. Axis orientation for on-axis loading is listed.

• Specifications are for single-axis systems measured 25 mm above the tabletop. Performance of combined multi-axis systems is payload and workpoint dependent. Consult factory for multi-axis or non-standard applications.

• -PLUS requires the use of an Aerotech controller.

## ANT95-L Series SPECIFICATIONS

Electrical Specifications	ANT95-25-L	ANT95-25-L-PLUS	ANT95-50-L	ANT95-50-L-PLUS
Drive System	Brushless Linear Servomotor			
Feedback	Noncontact Linear Encoder			
Maximum Bus Voltage	±40 VDC			
Limit Switches	5 V, Normally Closed			
Home Switch	Near Center			

Electrical Specifications	ANT95-75-L	ANT95-75-L-PLUS	ANT95-100-L	ANT95-100-L-PLUS
Drive System	Brushless Linear Servomotor			
Feedback	Noncontact Linear Encoder			
Maximum Bus Voltage	±40 VDC			
Limit Switches	5 V, Normally Closed			
Home Switch	Near Center			

Recommended Controller	ANT95-25-L	ANT95-25-L-PLUS	ANT95-50-L	ANT95-50-L-PLUS
Multi-Axis	A3200	Npaq-MXR Npaq MR-MXH Ndrive ML-MXH		
	Ensemble	Epaq-MXH Epaq MR-MXH Ensemble ML-MXH		
Single Axis	Soloist	Soloist ML-MXH		

Notes:  
1. Linear amplifiers are required to achieve the listed specifications. Other options are available.

Recommended Controller	ANT95-75-L	ANT95-75-L-PLUS	ANT95-100-L	ANT95-100-L-PLUS
Multi-Axis	A3200	Npaq-MXR Npaq MR-MXH Ndrive ML-MXH		
	Ensemble	Epaq-MXH Epaq MR-MXH Ensemble ML-MXH		
Single Axis	Soloist	Soloist ML-MXH		

Notes:  
1. Linear amplifiers are required to achieve the listed specifications. Other options are available.

Note: To ensure the achievement and repeatability of specifications over an extended period of time, environmental temperature must be controlled to within 0.25°C/24 hours. If this is not possible, alternate products are available. Please consult Aerotech Application Engineering for more information.



# ANT95-L/ANT95-L-PLUS Series PERFORMANCE

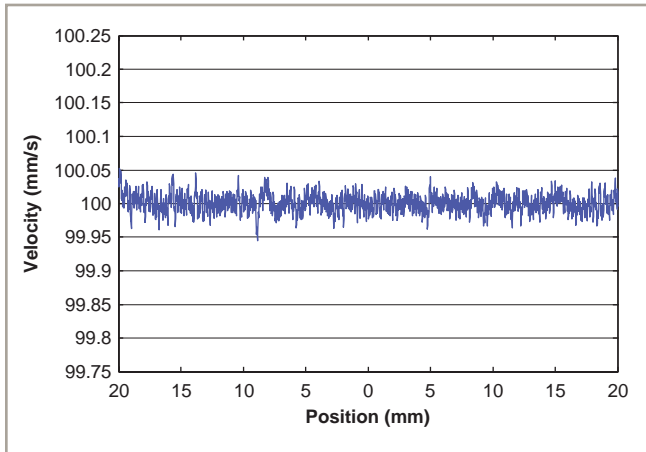

ANT95-50-L-PLUS velocity performance at 100 mm/s and 1 kg payload. Excellent speed stability is another feature of the ANT series stages.

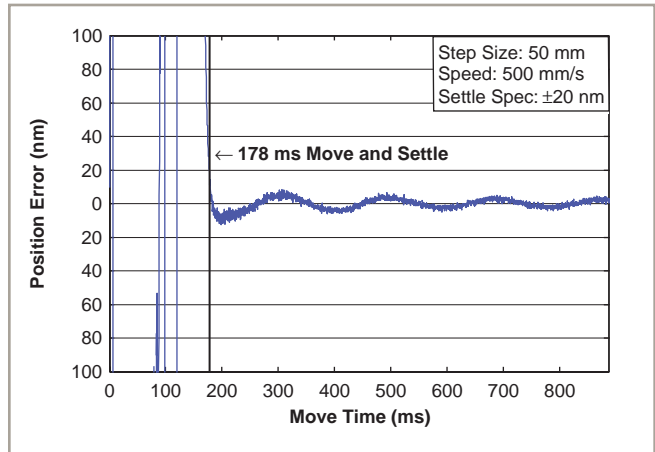

ANT95-50-L-PLUS step and settle performance at full travel and 1 kg payload. Outstanding settling time enhances throughput of most applications.

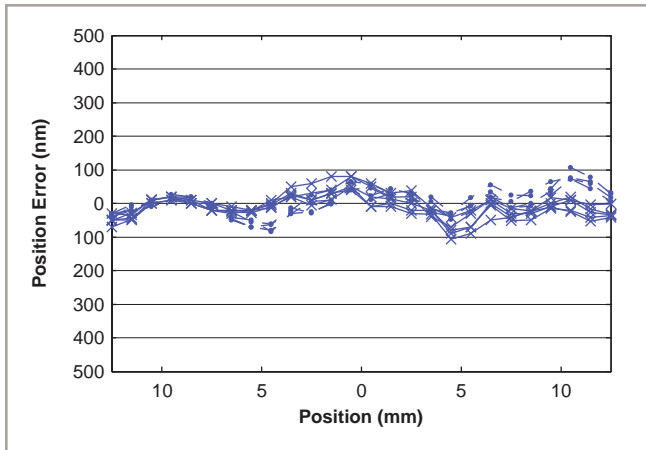

ANT95-25-L-PLUS accuracy and repeatability. This multiple test run over an extended period of time shows the high level of system accuracy and repeatability.

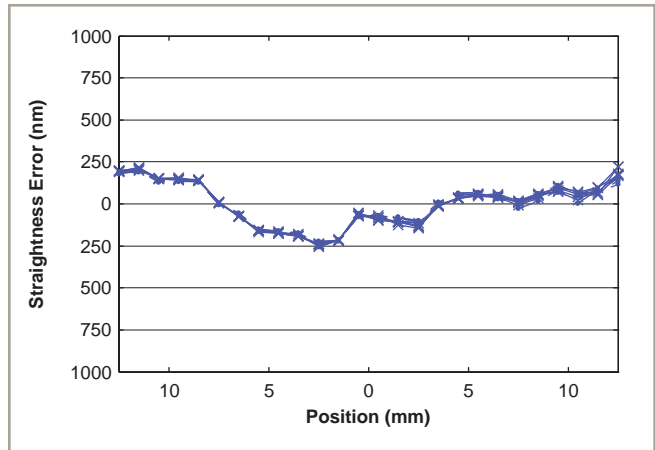

ANT95-25-L-PLUS straightness error, five runs, bi-directional. Exceptional and highly repeatable – five times more accurate than the stated specification.

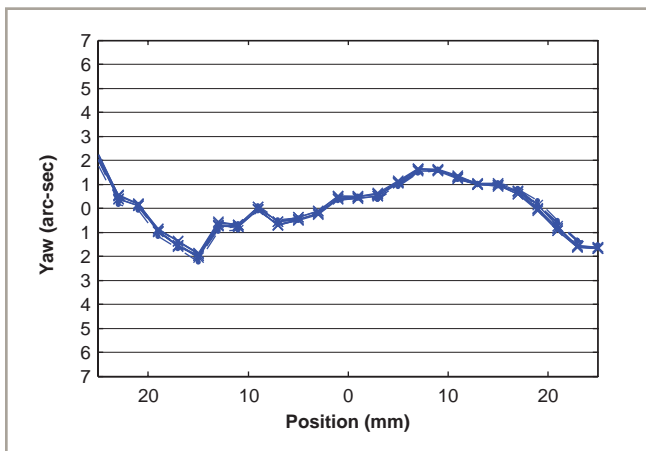

ANT95-50-L-PLUS yaw, five runs, bi-directional. Highly repeatable, minimal yaw error enhances system positioning accuracy.

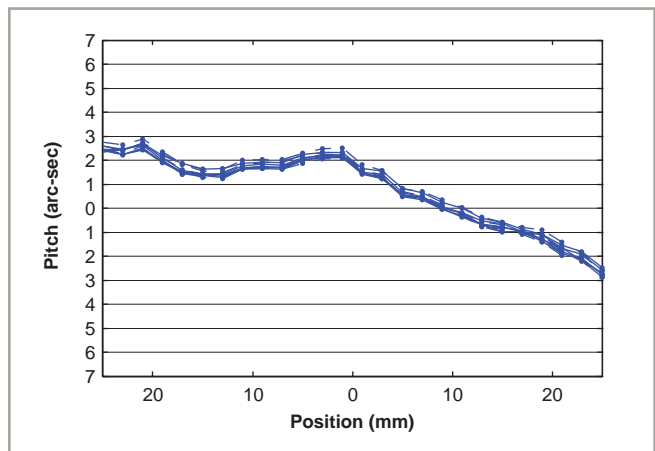

ANT95-50-L-PLUS pitch, five runs, bi-directional. Excellent repeatability/accuracy contribute to improved processing.

ANT95-25-L/ANT95-25-L-PLUS DIMENSIONS

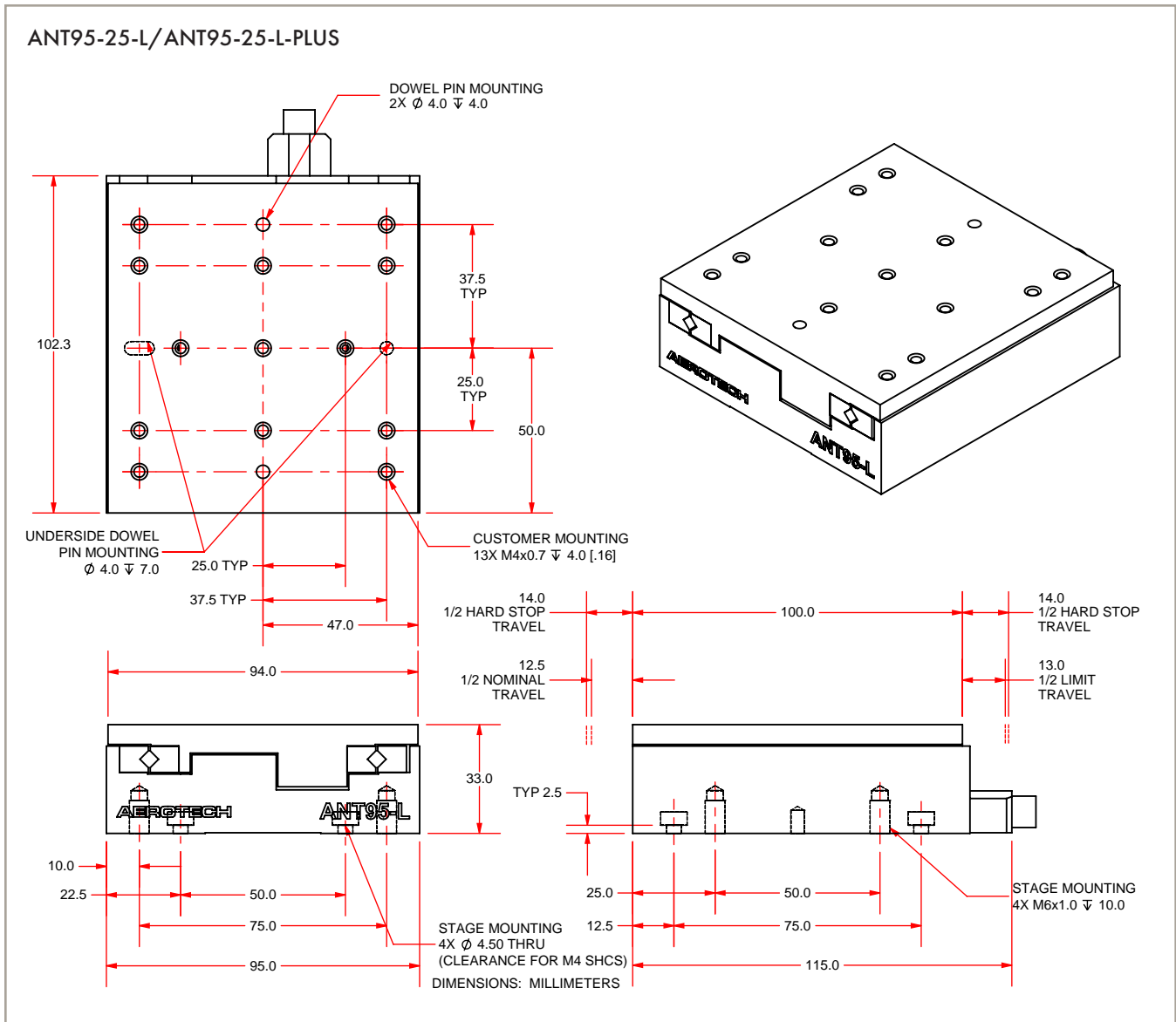

# ANT95-50-L/ANT95-50-L-PLUS DIMENSIONS

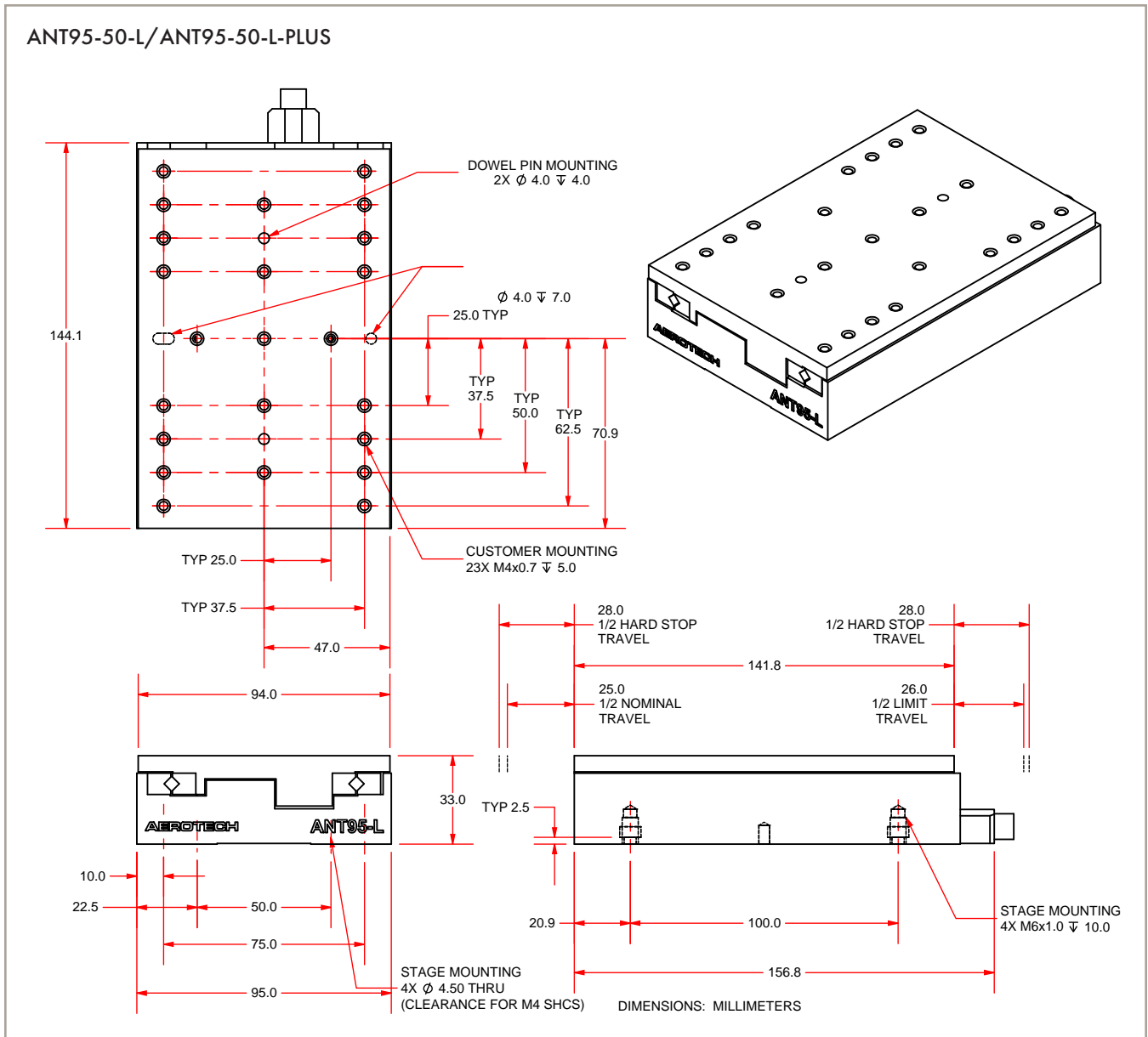

ANT95-75-L/ANT95-75-L-PLUS DIMENSIONS

ANT95-75-L/ANT95-75-L-PLUS

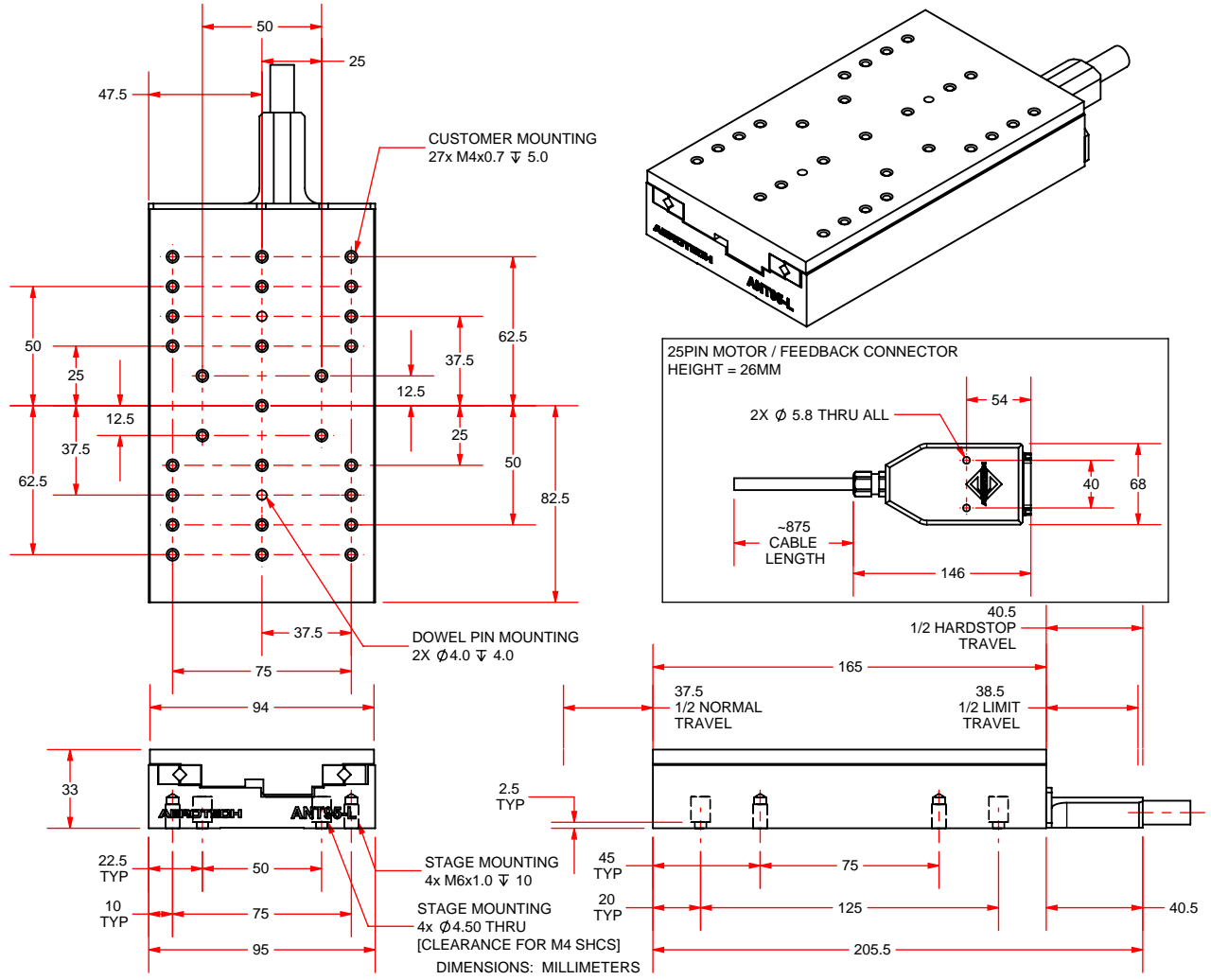

# ANT95-100-L/ANT95-100-L-PLUS DIMENSIONS

## ANT95-100-L/ANT95-100-L-PLUS

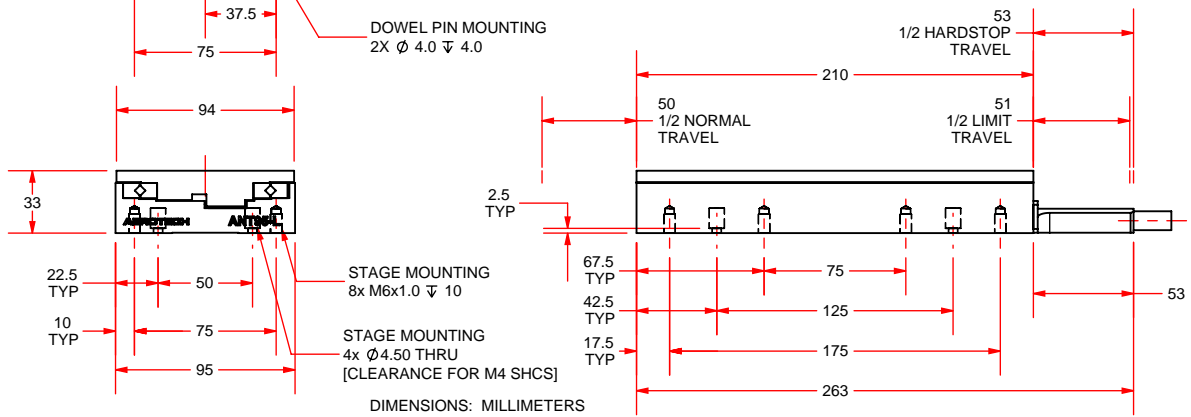
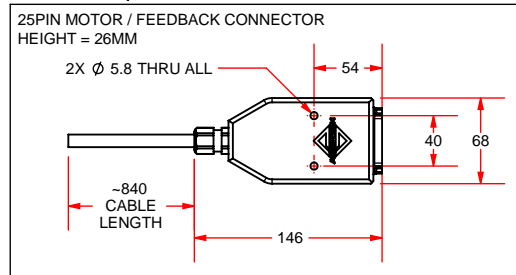
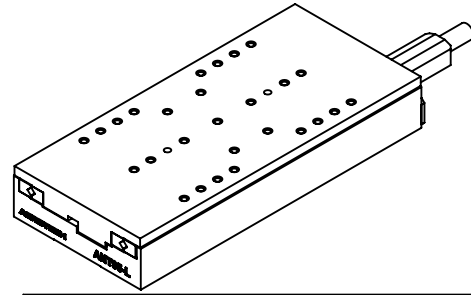
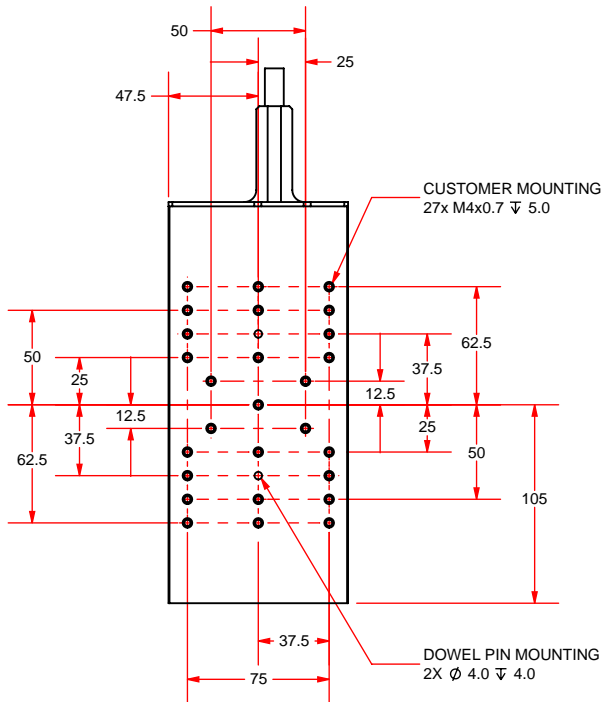

# ANT95-25-L/ANT95-50-L and ANT95-25-L-PLUS/ANT95-50-L-PLUS Mounting Plate DIMENSIONS

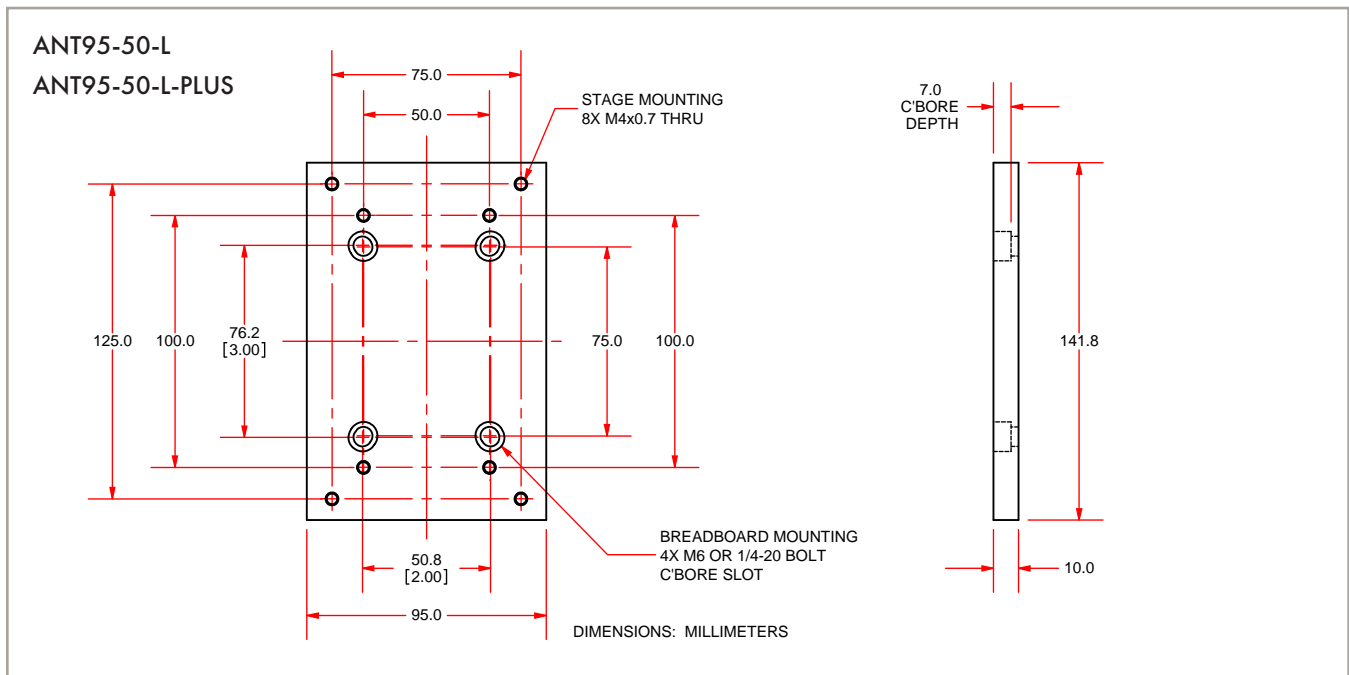
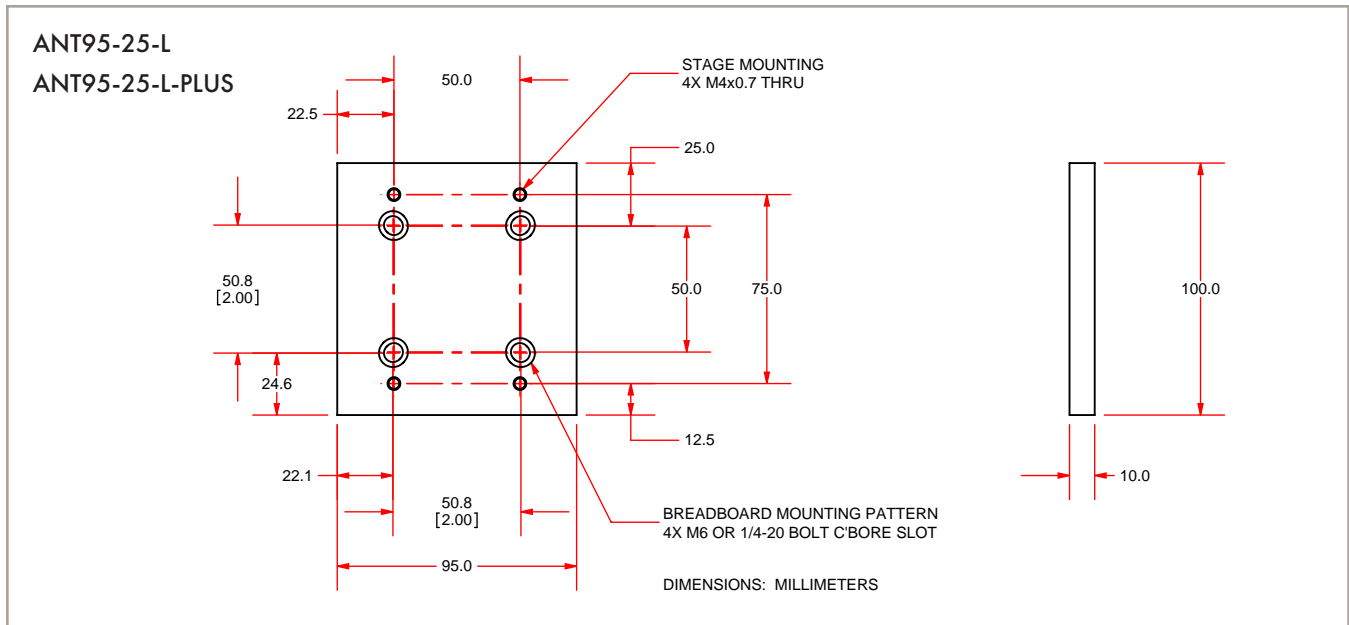



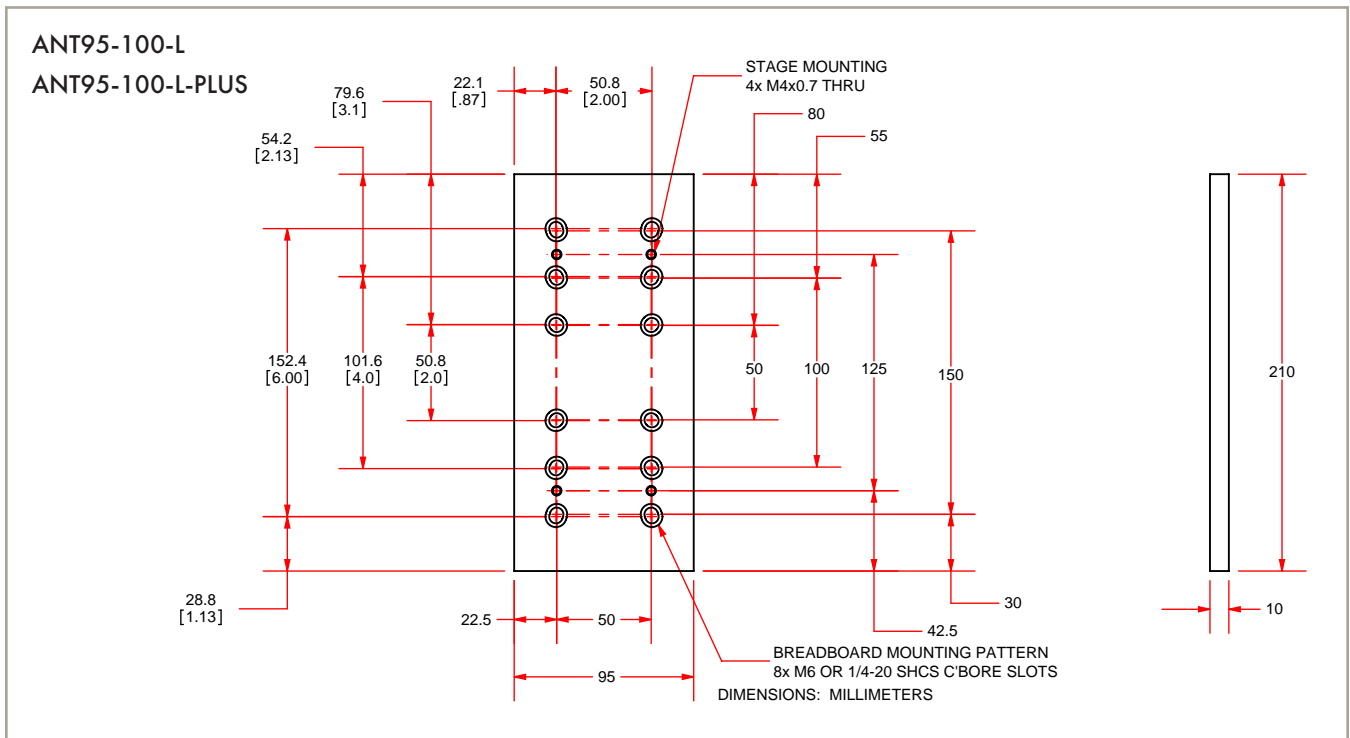
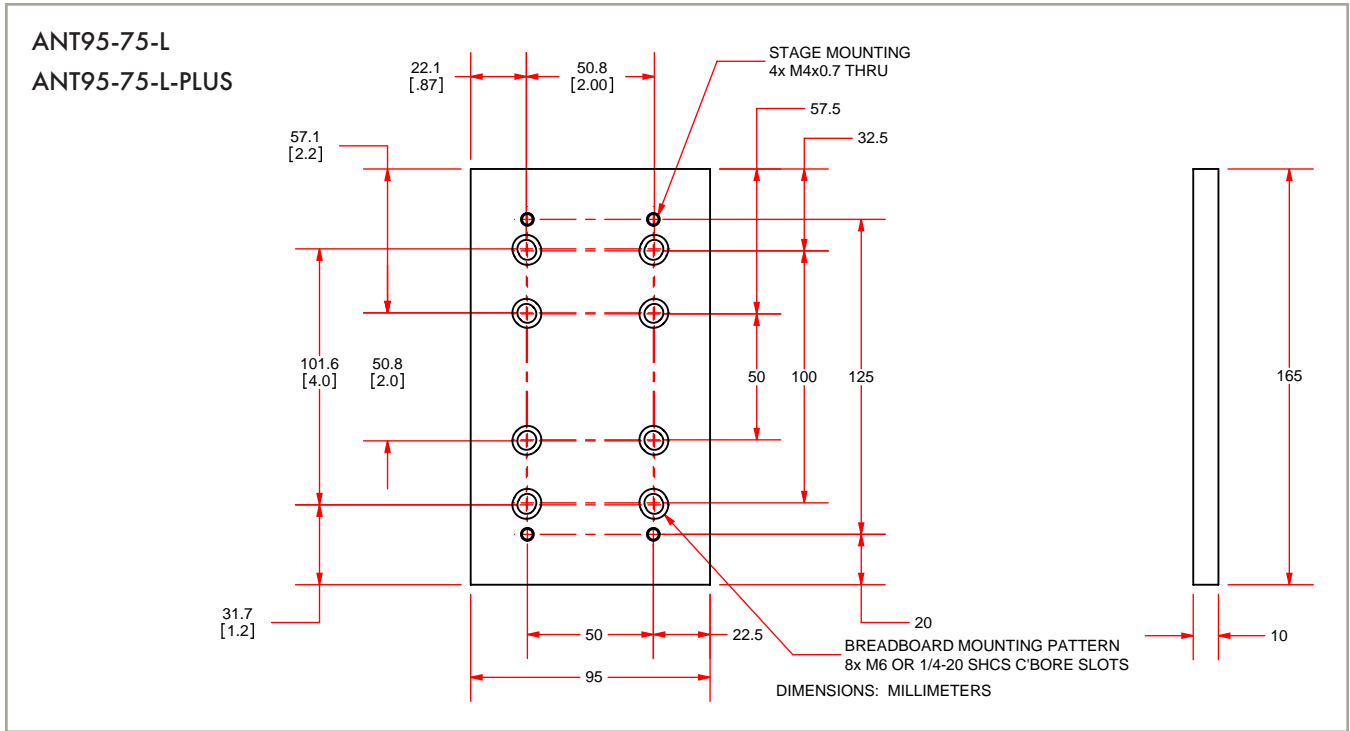

## ANT95-L Series ORDERING INFORMATION

### ANT95-L Series Linear Stage

ANT95-L/ANT95-L-PLUS Aerotech nanotranslation crossed-roller linear positioner

#### Linear Stage Travel

ANT95-25-L	25 mm (1 in) travel stage with proprietary direct-drive motor technology, 1 Vp-p sinusoidal output linear encoder and limits
ANT95-25-L-PLUS	25 mm (1 in) travel stage with proprietary direct-drive motor technology, 1 Vp-p sinusoidal output linear encoder and limits (High Accuracy Version)
ANT95-50-L	50 mm (2 in) travel stage with proprietary direct-drive motor technology, 1 Vp-p sinusoidal output linear encoder and limits
ANT95-50-L-PLUS	50 mm (2 in) travel stage with proprietary direct-drive motor technology, 1 Vp-p sinusoidal output linear encoder and limits (High Accuracy Version)
ANT95-75-L	75 mm (3 in) travel stage with proprietary direct-drive motor technology, 1 Vp-p sinusoidal output linear encoder and limits
ANT95-75-L-PLUS	75 mm (3 in) travel stage with proprietary direct-drive motor technology, 1 Vp-p sinusoidal output linear encoder and limits (High Accuracy Version)
ANT95-100-L	100 mm (4 in) travel stage with proprietary direct-drive motor technology, 1 Vp-p sinusoidal output linear encoder and limits
ANT95-100-L-PLUS	100 mm (4 in) travel stage with proprietary direct-drive motor technology, 1 Vp-p sinusoidal output linear encoder and limits (High Accuracy Version)

#### Options

-MP	Breadboard mounting plate
-AP	XY adapter plate (6 mm thick; ANT95-50-L and ANT95-50-L-PLUS only)

# ANT95-XY Series

## Two-Axis XY Direct-Drive Nanopositioning Stages

- Integrated low-profile XY linear motor stage
- 25 mm x 25 mm or 50 mm x 50 mm travel
- Nanometer-level performance in a large travel format
- High resolution (1 nm), repeatability (75 nm), and accuracy (250 nm) per axis
- In-position stability of <1 nm
- Anti-creep crossed-roller bearings
- High dynamic performance

nano Motion Technology



### Introduction

Aerotech's ANT series stages are the world's first nanometer-level positioning systems with greater than 25 mm travel. The ANT95-XY crossed-roller-bearing, linear motor, dual-axis stage continues the evolution of the ANT series of stages. The ANT95-XY and ANT95-XY-PLUS are three-piece designs that allow travel in two dimensions (X and Y). The sleek design provides an extremely low profile of only 60 mm. The stage comes with proprietary direct-drive motor technology, noncontact linear encoders, limits, integrated cable management system, and two grades of accuracy.

### Stage Design

The ANT95-XY design allows critical elements such as orthogonality, straightness, and flatness to be optimized, resulting in a stage with exceptional geometrical tolerances. Aerotech's direct-drive technology has no hysteresis or backlash, enabling accurate and repeatable nanometer-scale motion in both the X and Y dimensions. Both travel options (25 mm x 25 mm or 50 mm x 50 mm) come with the 60 mm profile height. You can expect outstanding accuracy, position repeatability, and in-position stability with the ANT95-XY stage.

### Noncontact Direct-Drive

Only noncontact direct-drive technology offers the robust, accurate, and high-speed positioning necessary for mass production of precision devices. ANT95-XY stages utilize advanced direct-drive technology pioneered by Aerotech to achieve the highest level of positioning performance. This direct-drive technology is high-performance, non-cogging,

noncontact, high-speed, high-resolution, and high-accuracy. This unique drive and bearing combination, packaged in an extremely small profile and footprint, offers tangible advantages in many applications such as high-precision positioning, disk-drive fabrication, fiber alignment, optical delay element actuation, sensor testing, and scanning processes that demand smooth and precise motion. The integrated cable management system is designed for long life and to minimize drag forces.

### Multi-Axis Configurations

The ANT95-XY can be combined with other Aerotech ANT series products (vertical lift stages, direct-drive rotaries, and goniometers) to create unique, high performance, multi-axis systems.

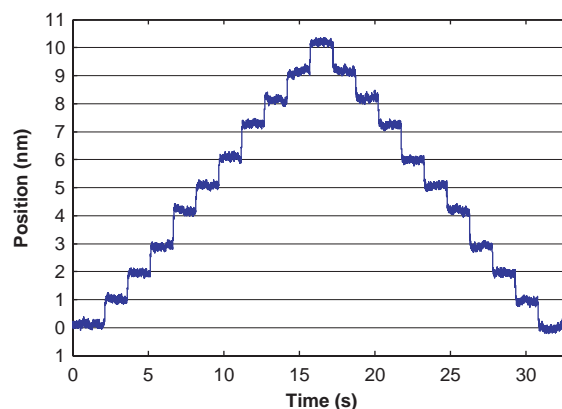

ANT95-25-XY-PLUS lower axis 1 nm step plot. Best-in-class resolution and exceptional in-position stability for large travel stages.

## ANT95-XY Series SPECIFICATIONS

Mechanical Specifications	ANT95-25-XY	ANT95-25-XY-PLUS	ANT95-50-XY	ANT95-50-XY-PLUS
Travel	25 mm	25 mm	50 mm	50 mm
Accuracy <sup>(1)</sup>	±2.5 µm (±100 µin)	±250 nm (±10 µin)	±2.5 µm (±100 µin)	±250 nm (±10 µin)
Resolution	1 nm (0.04 µin)	1 nm (0.04 µin)	1 nm (0.04 µin)	1 nm (0.04 µin)
Repeatability (Bi-Directional) <sup>(4)</sup>	±100 nm (±4 µin)	±75 nm (±3 µin)	±100 nm (±4 µin)	±75 nm (±3 µin)
Repeatability (Uni-Directional)	±25 nm (±1 µin)	±25 nm (±1 µin)	±25 nm (±1 µin)	±25 nm (±1 µin)
Straightness <sup>(1)</sup>	±1.0 µm (±40 µin)	±1.0 µm (±40 µin)	±1.0 µm (±40 µin)	±1.0 µm (±40 µin)
Flatness <sup>(1)</sup>	±1.0 µm (±40 µin)	±1.0 µm (±40 µin)	±1.0 µm (±40 µin)	±1.0 µm (±40 µin)
Pitch	10 arc sec	10 arc sec	10 arc sec	10 arc sec
Roll	10 arc sec	10 arc sec	10 arc sec	10 arc sec
Yaw	5 arc sec	5 arc sec	5 arc sec	5 arc sec
Orthogonality	10 arc sec	3 arc sec	10 arc sec	3 arc sec
Maximum Speed	500 mm/s (20 in/s) (Upper Axis)	500 mm/s (20 in/s) (Upper Axis)	500 mm/s (20 in/s) (Upper Axis)	500 mm/s (20 in/s) (Upper Axis)
Maximum Acceleration	4.5 g - 45 m/s <sup>2</sup> (No Load) (Upper Axis)	4.5 g - 45 m/s <sup>2</sup> (No Load) (Upper Axis)	2.75 g - 27 m/s <sup>2</sup> (No Load) (Upper Axis)	2.75 g - 27 m/s <sup>2</sup> (No Load) (Upper Axis)
Speed Stability	See graph for typical performance			
Settling Time	See graph for typical performance			
In-Position Stability <sup>(2)</sup>	<1 nm (<0.04 µin)	<1 nm (<0.04 µin)	<1 nm (<0.04 µin)	<1 nm (<0.04 µin)
Maximum Force (Continuous)	7.75 N	7.75 N	9.5 N	9.5 N
Load Capacity <sup>(3)</sup>	Horizontal	4.0 kg (8.8 lb)	4.0 kg (8.8 lb)	6.0 kg (13.2 lb)
	Upper Axis	0.45 kg (1.0 lb)	0.45 kg (1.0 lb)	0.8 kg (1.8 lb)
Moving Mass	Lower Axis	1.13 kg (2.5 lb)	1.13 kg (2.5 lb)	2.1 kg (4.6 lb)
	Stage Mass	1.8 kg (4 lb)	1.8 kg (4 lb)	3.2 kg (7 lb)
Material	Aluminum Body/Black Hardcoat Finish			
MTBF (Mean Time Between Failure)	20,000 Hours			

Notes:

- Certified with each stage.
  - In-Position Jitter listing is 3 sigma value.
  - Axis orientation for on-axis loading is listed.
- Specifications are for XY systems measured 25 mm above the tabletop. Consult factory for multi-axis or non-standard applications.
  - PLUS requires the use of an Aerotech controller.

Electrical Specifications	ANT95-25-XY	ANT95-25-XY-PLUS	ANT95-50-XY	ANT95-50-XY-PLUS
Drive System	Brushless Linear Servomotor			
Feedback	Noncontact Linear Encoder			
Maximum Bus Voltage	±40 VDC			
Limit Switches	5 V, Normally Closed			
Home Switch	Near Center			

Recommended Controller	ANT95-25-XY	ANT95-25-XY-PLUS	ANT95-50-XY	ANT95-50-XY-PLUS
Multi-Axis	A3200	Npaq-MXR Npaq MR-MXH Ndrive ML-MXH		
	Ensemble	Epaq-MXH Epaq MR-MXH Ensemble ML-MXH		
Single Axis	Soloist	Soloist ML-MXH		

Notes:

- Linear amplifiers are required to achieve the listed specifications. Other options are available.

Note: To ensure the achievement and repeatability of specifications over an extended period of time, environmental temperature must be controlled to within 0.25°C/24 hours. If this is not possible, alternate products are available. Please consult Aerotech Application Engineering for more information.

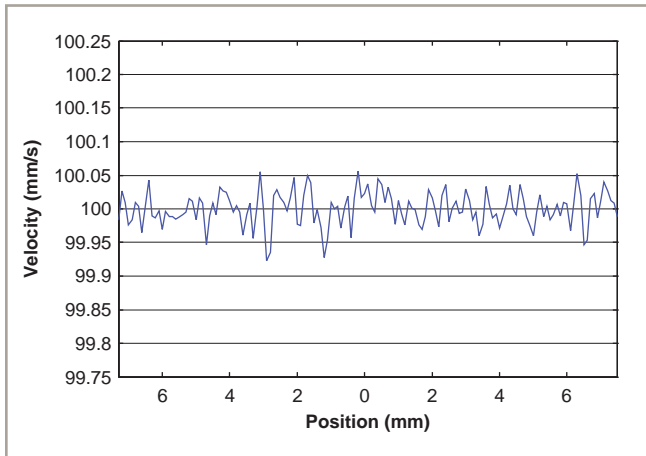

ANT95-25-XY-PLUS velocity performance at 100 mm/s and 1 kg payload for the X (lower) axis. This outstanding speed stability enhances most scanning or laser machining applications.

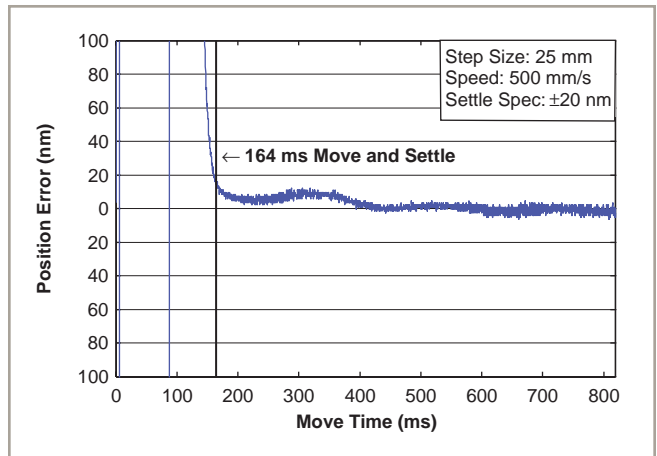

ANT95-25-XY-PLUS step and settle performance at full travel and 1 kg payload for the X (lower) axis. Industry-best settling times significantly improve throughput for most applications.

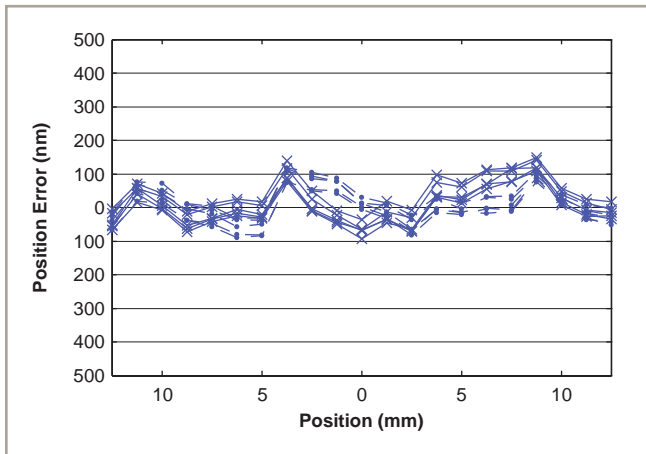

ANT95-25-XY-PLUS accuracy and repeatability, five runs, bi-directional for the X (lower) axis. The total accuracy of 240 nm over 25 mm travel is significantly better than other offerings and half of its stated specification.

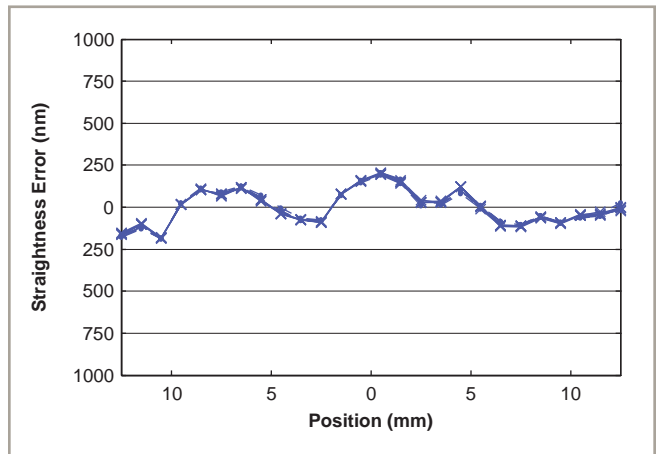

ANT95-25-XY-PLUS bi-directional straightness error for the Y (upper) axis. Significantly (five times) better than stated specification.

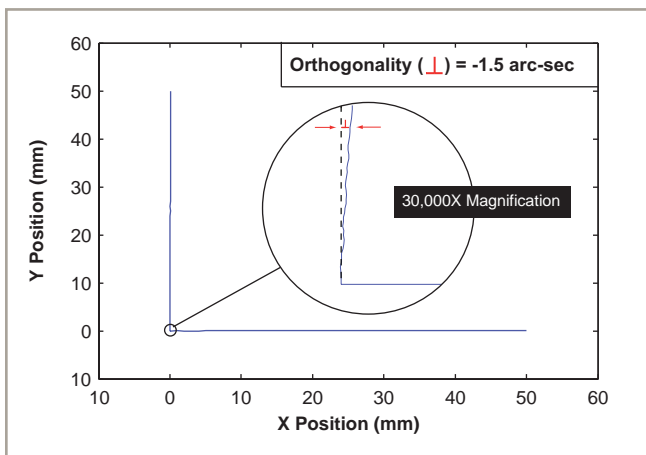

ANT95-50-XY-PLUS orthogonality. The inset is exaggerated 30,000X for clarity. Exceptionally small angular (orthogonality) error significantly enhances system accuracy.

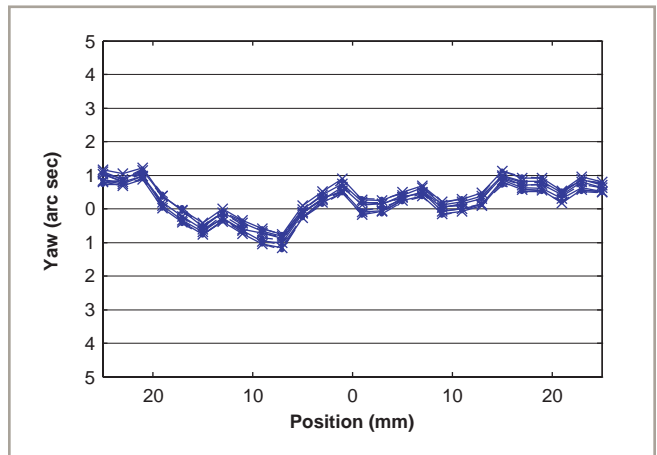

ANT95-50-XY-PLUS Y (upper) axis yaw, five runs, bi-directional. Highly repeatable, lowest angular error over full travel.

ANT95-25-XY/ANT95-25-XY-PLUS DIMENSIONS

ANT95-25-XY/ANT95-25-XY-PLUS

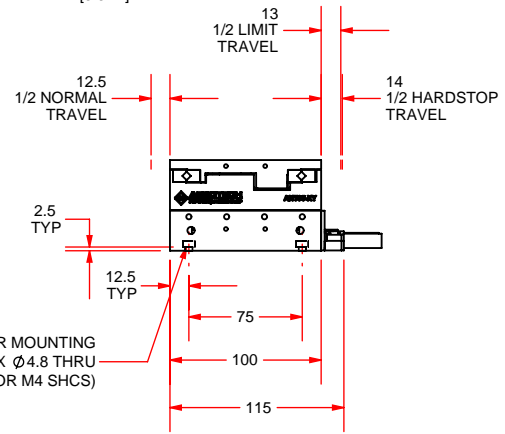
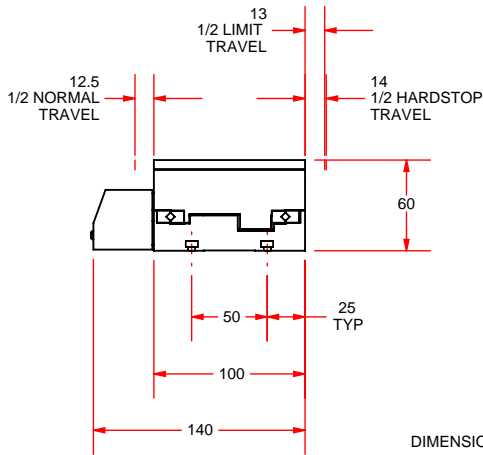
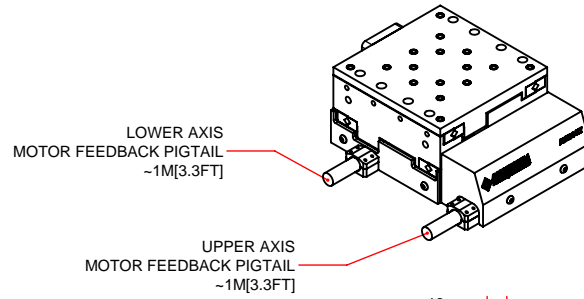
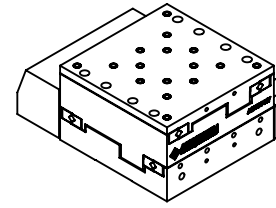
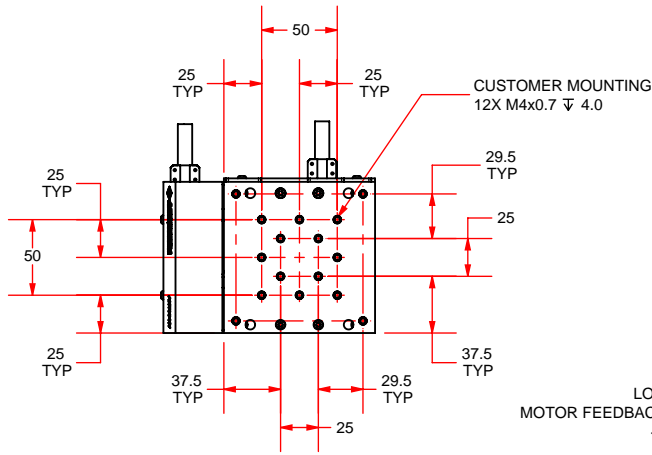

DIMENSIONS: MILLIMETERS



# ANT95-50-XY/ANT95-50-XY-PLUS DIMENSIONS

## ANT95-50-XY/ANT95-50-XY-PLUS

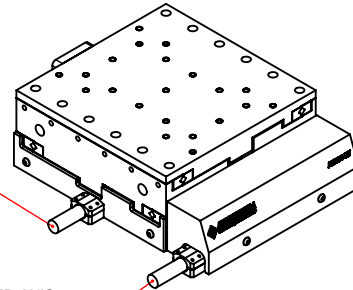
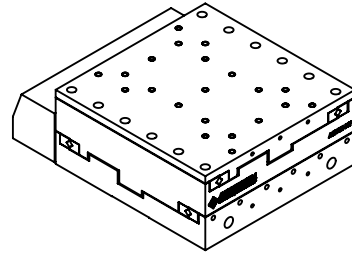
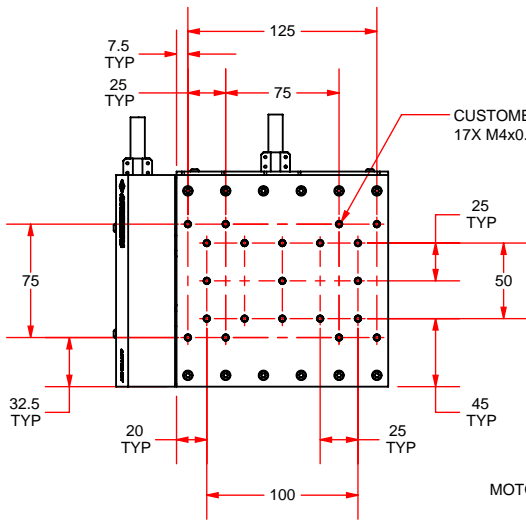

LOWER AXIS  
MOTOR FEEDBACK PIGTAIL  
~1M[3.3FT]

UPPER AXIS  
MOTOR FEEDBACK PIGTAIL  
~1M[3.3FT]

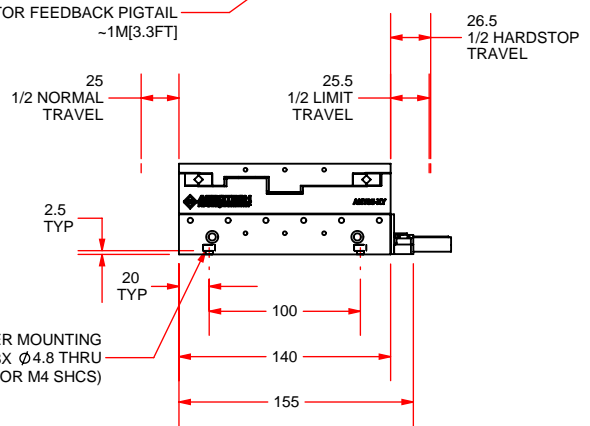
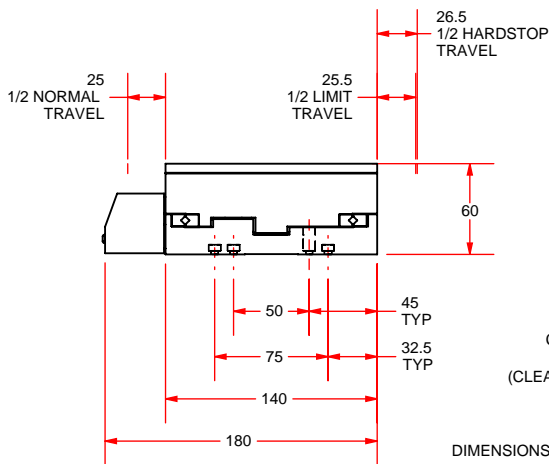

DIMENSIONS: MILLIMETERS

## ANT95-25-XY/ANT95-50-XY and ANT95-25-XY-PLUS/ANT95-50-XY-PLUS Mounting Plate DIMENSIONS

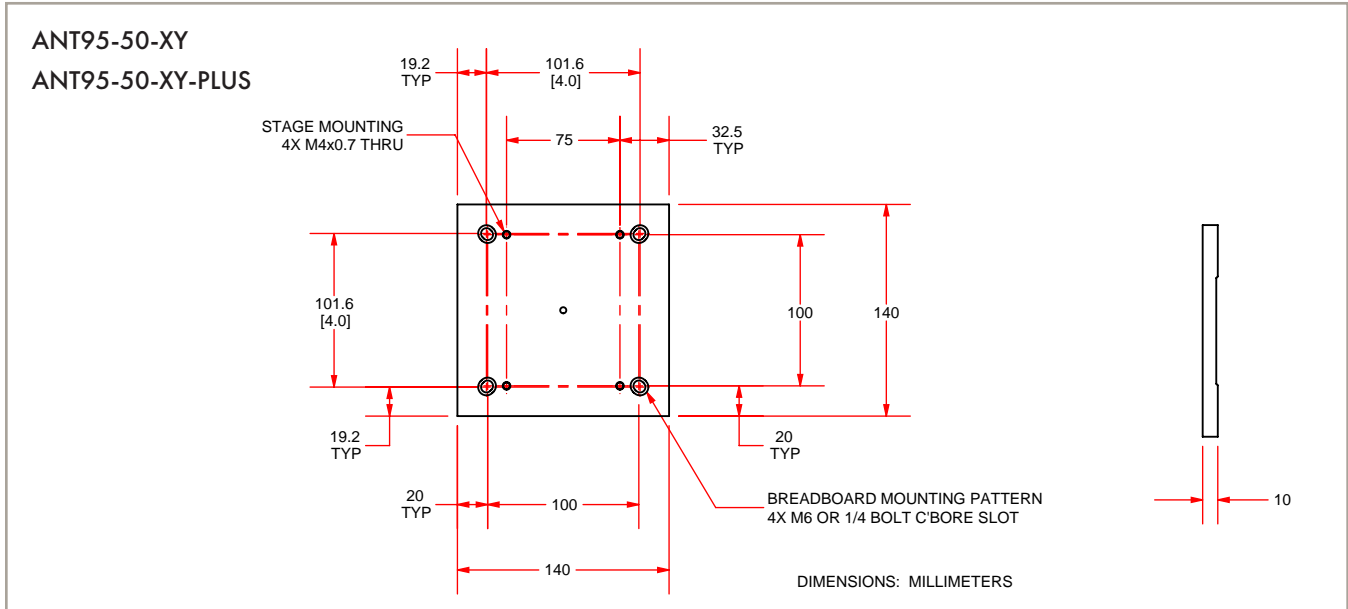
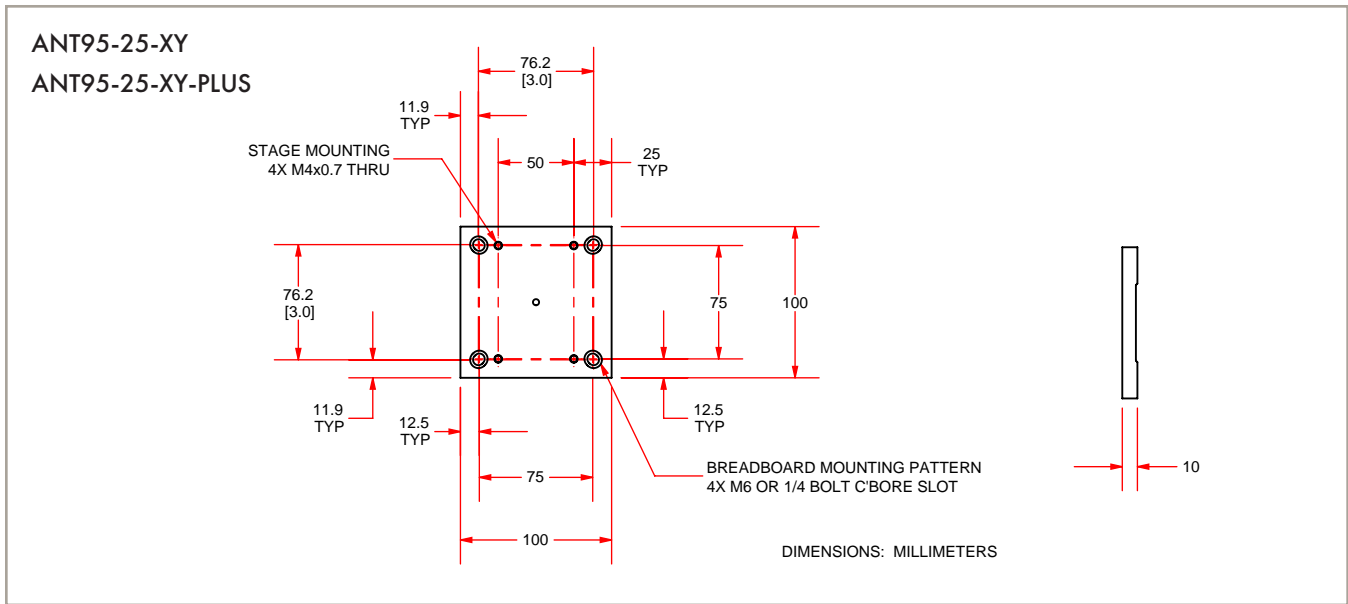

### ANT95-XY Series ORDERING INFORMATION

#### ANT95-XY Series Linear Stage

ANT95-XY/ANT95-XY-PLUS Aerotech nanotranslation crossed-roller linear positioner

#### Linear Stage Travel

ANT95-25-XY	25 mm (1 in) XY travel stage with proprietary direct-drive motor technology, 1 Vp-p sinusoidal output linear encoder, and limits
ANT95-25-XY-PLUS	25 mm (1 in) XY travel stage with proprietary direct-drive motor technology, 1 Vp-p sinusoidal output linear encoder, and limits (High Accuracy Version)
ANT95-50-XY	50 mm (2 in) XY travel stage with proprietary direct-drive motor technology, 1 Vp-p sinusoidal output linear encoder, and limits
ANT95-50-XY-PLUS	50 mm (2 in) XY travel stage with proprietary direct-drive motor technology, 1 Vp-p sinusoidal output linear encoder, and limits (High Accuracy Version)

#### Options

-MP Breadboard mounting plate

# ANT95-XY-ULTRA

## Two-Axis XY Direct-Drive Nanopositioning Stages

- Integrated low profile XY linear motor stage
- 25 mm x 25 mm or 50 mm x 50 mm travel
- Nanometer-level performance in a large travel format
- 2D system accuracy is 250 nm
- In-position stability of <math><1\text{ nm}</math>
- High dynamic performance

nano Motion Technology



### Introduction

Aerotech's ANT95-XY-ULTRA is a long travel (up to 50 mm x 50 mm) nanopositioner for XY applications. Each axis uses crossed-roller bearings, as well as Aerotech's unique direct-drive for non-cogging, zero backlash motion. In addition, each stage receives a two-dimensional correction to achieve unmatched nanometer resolution, accuracy, and repeatability. This unique drive and bearing combination, packaged in an extremely low profile and small footprint, offers tangible advantages in your motion application.

The ANT95-XY-ULTRA extends the performance capability of Aerotech's ANT95-XY stage series to levels found nowhere else. The exceptional geometric and dynamic performance of the ANT95-XY-ULTRA make it an ideal choice for nearly all high-end motion applications in the lab or in production environments.

### ULTRA Trajectory Management System

In order to achieve the highest possible system accuracy from our multi-axis nanopositioning systems, Aerotech has developed an advanced, interactive, dynamic trajectory management system. To take advantage of this sophisticated interactive calibration system, the mechanical system has to be completely assembled and functionally tested prior to calibration in our best-in-class metrology labs. Nano-level system accuracy can only be achieved under stringent environmental conditions, calibrating with the best test equipment, and utilizing the formidable capability of ULTIMUS. By implementing the ULTIMUS dynamic trajectory management system with the ANT95-XY-ULTRA, we are able to produce 2-dimensional accuracies of  $\pm 250\text{ nm}$  or better.

The plots below illustrate performance differences between a standard ANT95-XY and the -ULTRA version. Straightness errors, orthogonality errors, and accuracy errors caused by stage yawing are virtually eliminated.

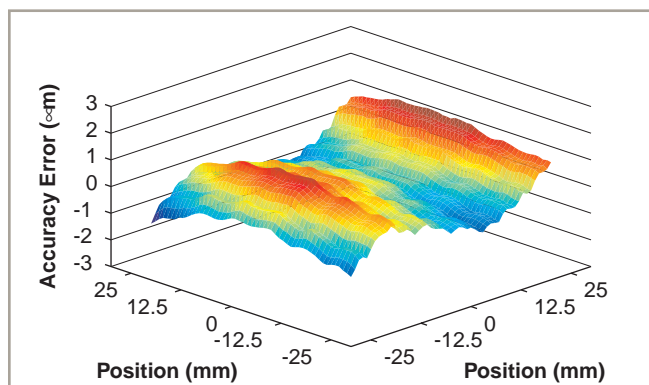

ANT95-50-XY 2D accuracy plot showing planar accuracy error including straightness, orthogonality, and stage yawing.

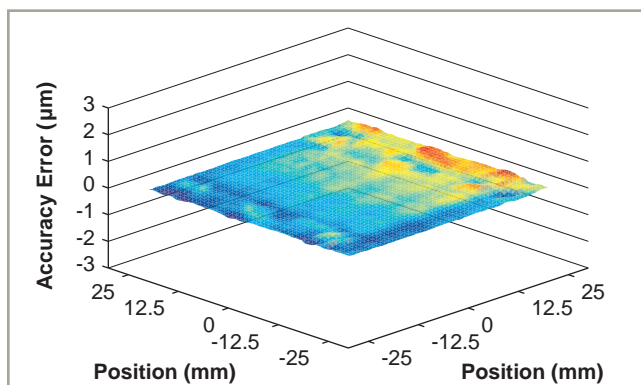

ANT95-50-XY-ULTRA – exceptional 2D system accuracy with Aerotech's ULTRA version.

## ANT95-XY-ULTRA Series SPECIFICATIONS

Mechanical Specifications	ANT95-25-XY-ULTRA	ANT95-50-XY-ULTRA	
Travel	25 mm	50 mm	
2D Accuracy <sup>(1)</sup>	±250 nm (±10 μin)	±250 nm (±10 μin)	
Resolution	1 nm (0.04 μin)	1 nm (0.04 μin)	
Repeatability (Bi-Directional) <sup>(1)</sup>	±75 nm (±3 μin)	±75 nm (±3 μin)	
Repeatability (Uni-Directional)	±25 nm (±1 μin)	±25 nm (±1 μin)	
Straightness <sup>(1)</sup>	±250 nm (±10 μin)	±250 nm (±10 μin)	
Flatness <sup>(1)</sup>	±1.0 μm (±40 μin)	±1.0 μm (±40 μin)	
Pitch	10 arc sec	10 arc sec	
Roll	10 arc sec	10 arc sec	
Yaw	5 arc sec	5 arc sec	
Orthogonality	1.0 arc sec	1.0 arc sec	
Maximum Speed	500 mm/s (20 in/s) (Upper Axis)	500 mm/s (20 in/s) (Upper Axis)	
Maximum Acceleration	4.5 g - 45 m/s <sup>2</sup> (No Load) (Upper Axis)	2.75 g - 27 m/s <sup>2</sup> (No Load) (Upper Axis)	
Speed Stability	See graph for typical performance		
Settling Time	See graph for typical performance		
In-Position Stability <sup>(2)</sup>	<1 nm (<0.04 μin)	<1 nm (<0.04 μin)	
Maximum Force (Continuous)	7.75 N	9.5 N	
Load Capacity <sup>(3)</sup>	Horizontal	4.0 kg (8.8 lb)	6.0 kg (13.2 lb)
	Upper Axis	0.45 kg (1.0 lb)	0.8 kg (1.8 lb)
Moving Mass	Lower Axis	1.13 kg (2.5 lb)	2.1 kg (4.6 lb)
	Stage Mass	1.8 kg (4 lb)	3.2 kg (7 lb)
Material	Aluminum Body/Black Hardcoat Finish		
MTBF (Mean Time Between Failure)	20,000 Hours		

Notes:

1. Certified with each stage.

2. In-Position Jitter listing is 3 sigma value.

3. Axis orientation for on-axis loading is listed.

• Specifications are for XY systems measured 25 mm above the tabletop. Consult factory for non-standard applications.

• -ULTRA requires the use of an Aerotech controller.

Electrical Specifications	ANT95-25-XY-ULTRA	ANT95-50-XY-ULTRA
Drive System	Brushless Linear Servomotor	
Feedback	Noncontact Linear Encoder	
Maximum Bus Voltage	±40 VDC	
Limit Switches	5 V, Normally Closed	
Home Switch	Near Center	

Recommended Controller	ANT95-25-XY-ULTRA	ANT95-50-XY-ULTRA
Multi-Axis	A3200	Npaq-MXR Npaq MR-MXH Ndrive ML-MXH
	Ensemble	Epaq-MXH Epaq MR-MXH Ensemble ML-MXH
Single Axis	Soloist	Soloist ML-MXH

Notes:

1. Linear amplifiers are required to achieve the listed specifications. Other options are available.

Note: To ensure the achievement and repeatability of specifications over an extended period of time, environmental temperature must be controlled to within 0.25°C/24 hours. If this is not possible, alternate products are available. Please consult Aerotech Application Engineering for more information.

# ANT95-XY-ULTRA Series PERFORMANCE

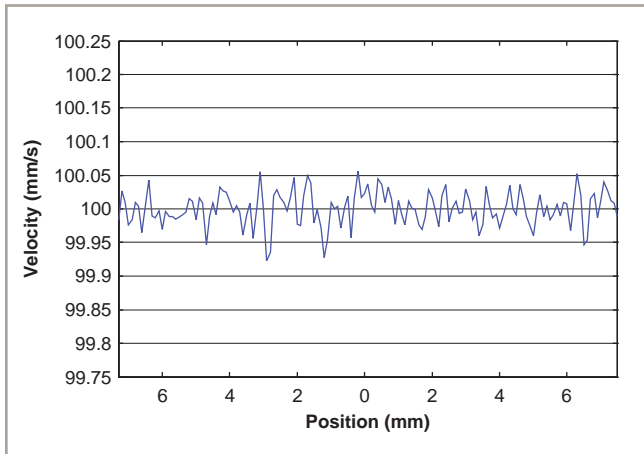

ANT95-25-XY-ULTRA velocity performance at 100 mm/s and 1 kg payload for the X (lower) axis. This outstanding speed stability enhances most scanning or laser machining applications.

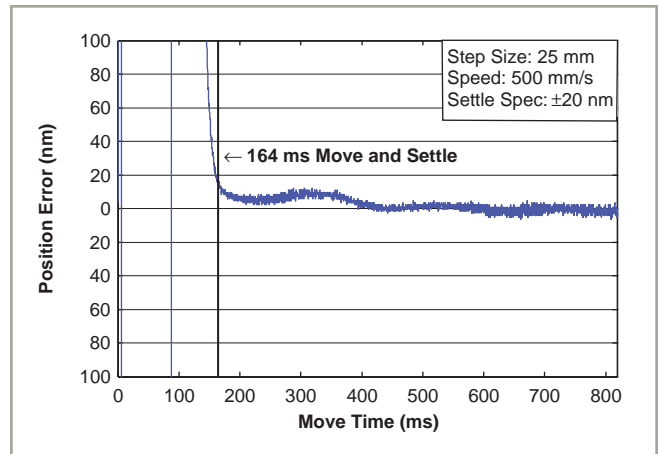

ANT95-25-XY-ULTRA step and settle performance at full travel and 1 kg payload for the X (lower) axis. Industry-best settling times significantly improve throughput for most applications.

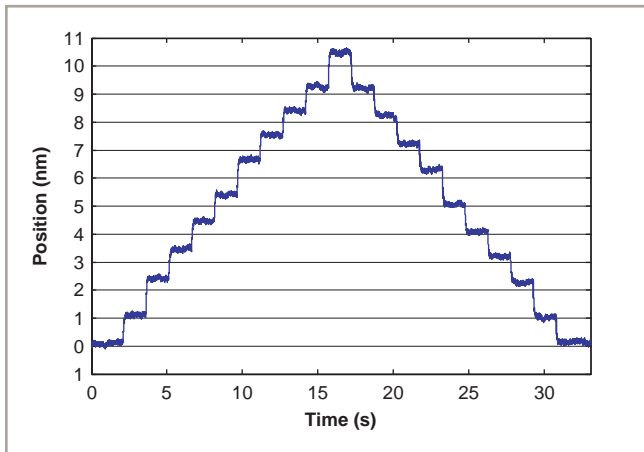

ANT95-25-XY-ULTRA lower axis, 1 nm step plot. Best-in-class resolution and exceptional in-position stability for large travel stages.

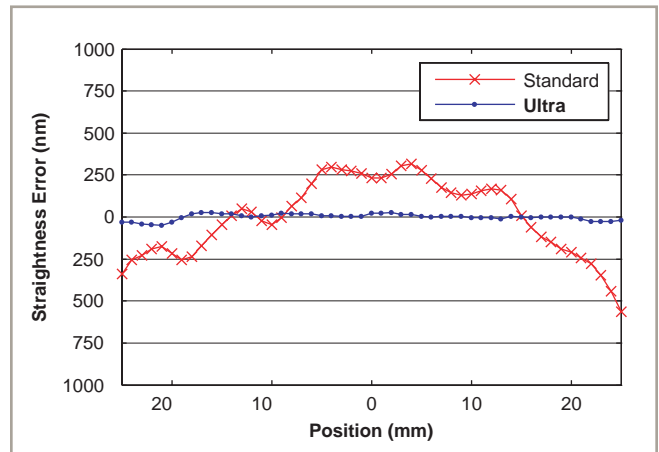

ANT95-25-XY straightness error comparison between the BASE and ULTRA models shows a dramatic improvement in this specification.

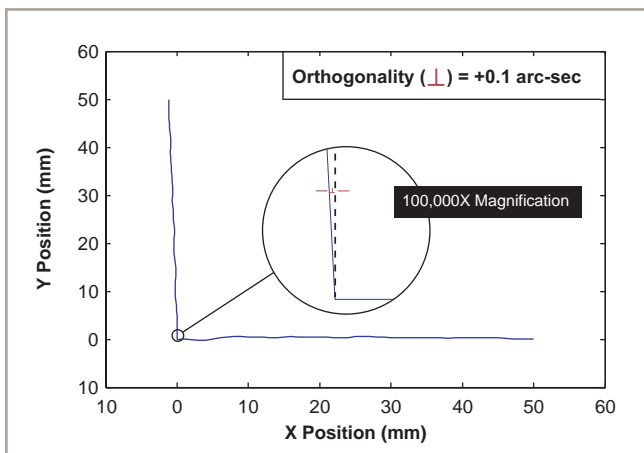

ANT95-50-XY-ULTRA orthogonality. The inset is magnified 100,000X for clarity. The ULTRA model orthogonality is a twenty-fold improvement over the BASE model orthogonality.

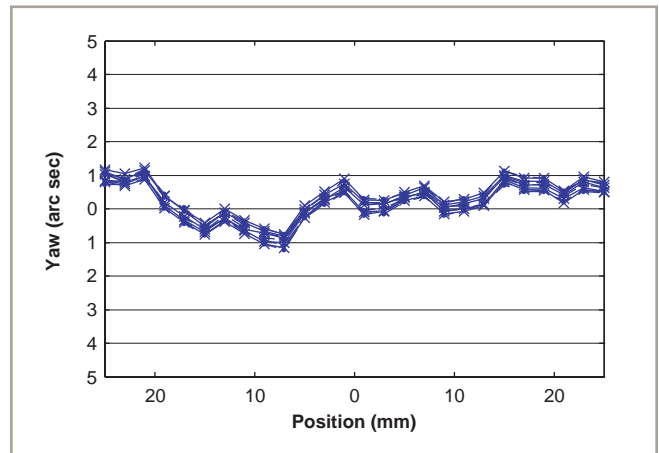

ANT95-50-XY-ULTRA Y (upper) axis yaw, five runs, bi-directional. Highly repeatable, lowest angular error over full travel.

ANT95-25-XY-ULTRA DIMENSIONS

ANT95-25-XY-ULTRA

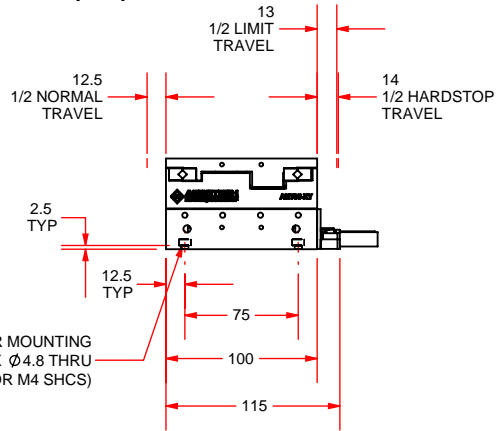
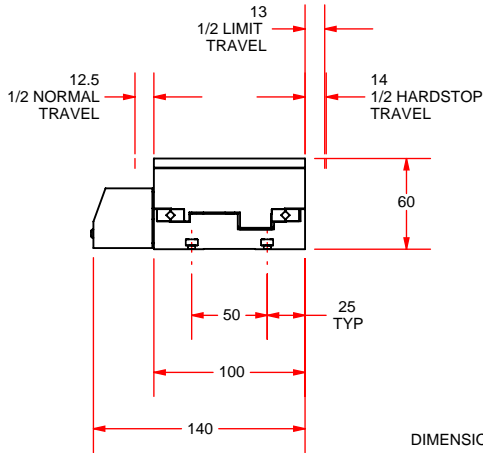
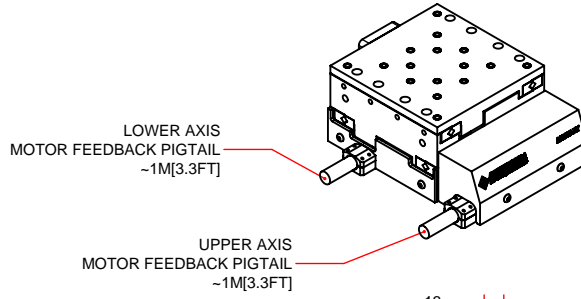
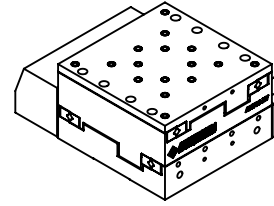
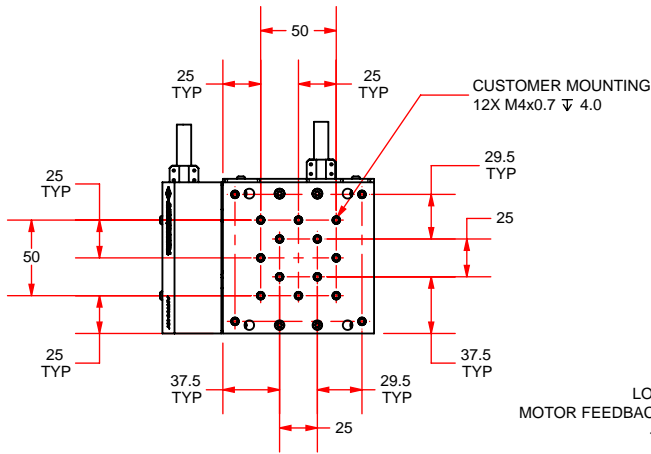

DIMENSIONS: MILLIMETERS

# ANT95-50-XY-ULTRA DIMENSIONS

## ANT95-50-XY-ULTRA

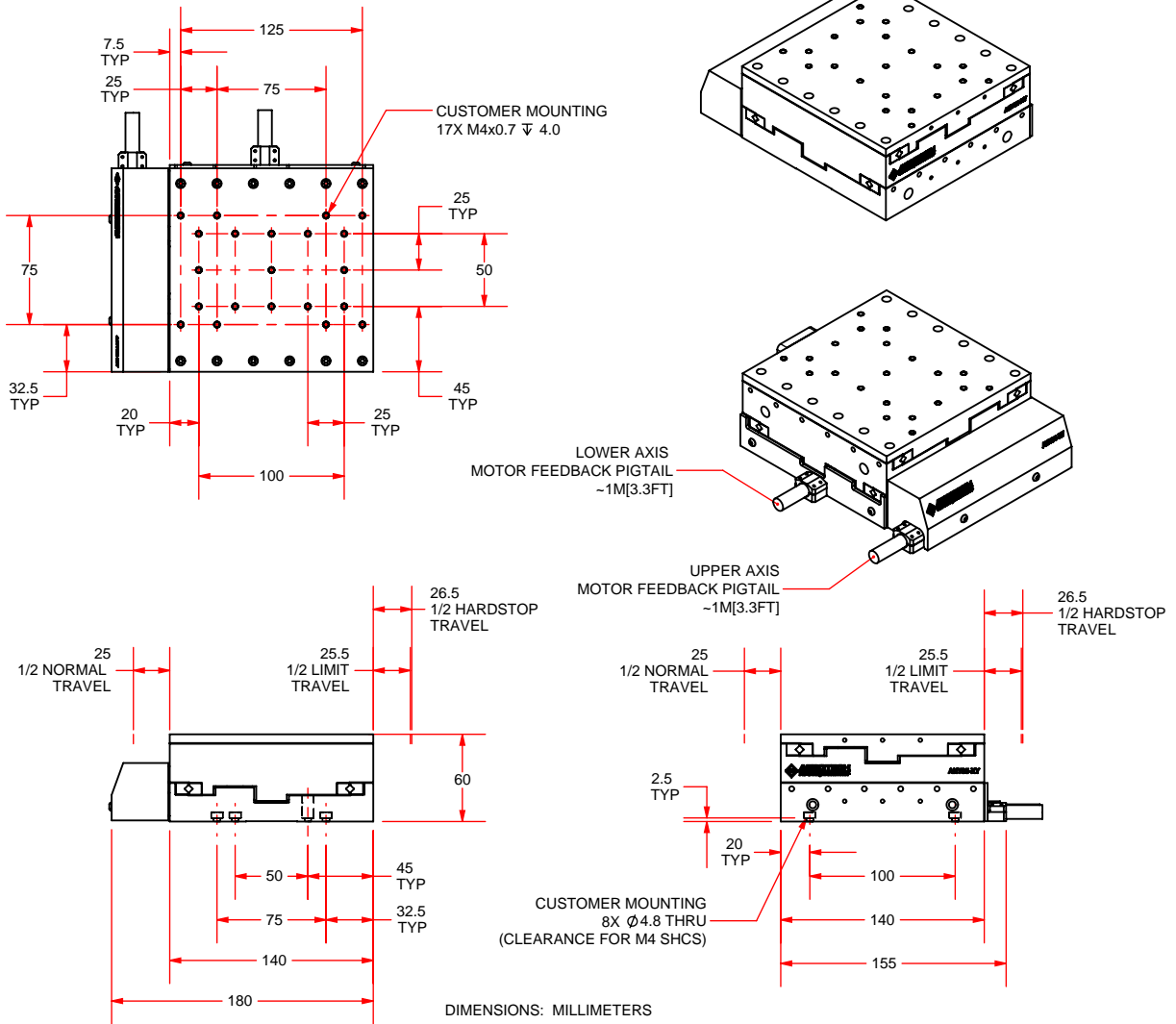



## ANT95-25-XY-ULTRA/ANT95-50-XY-ULTRA Mounting Plate DIMENSIONS

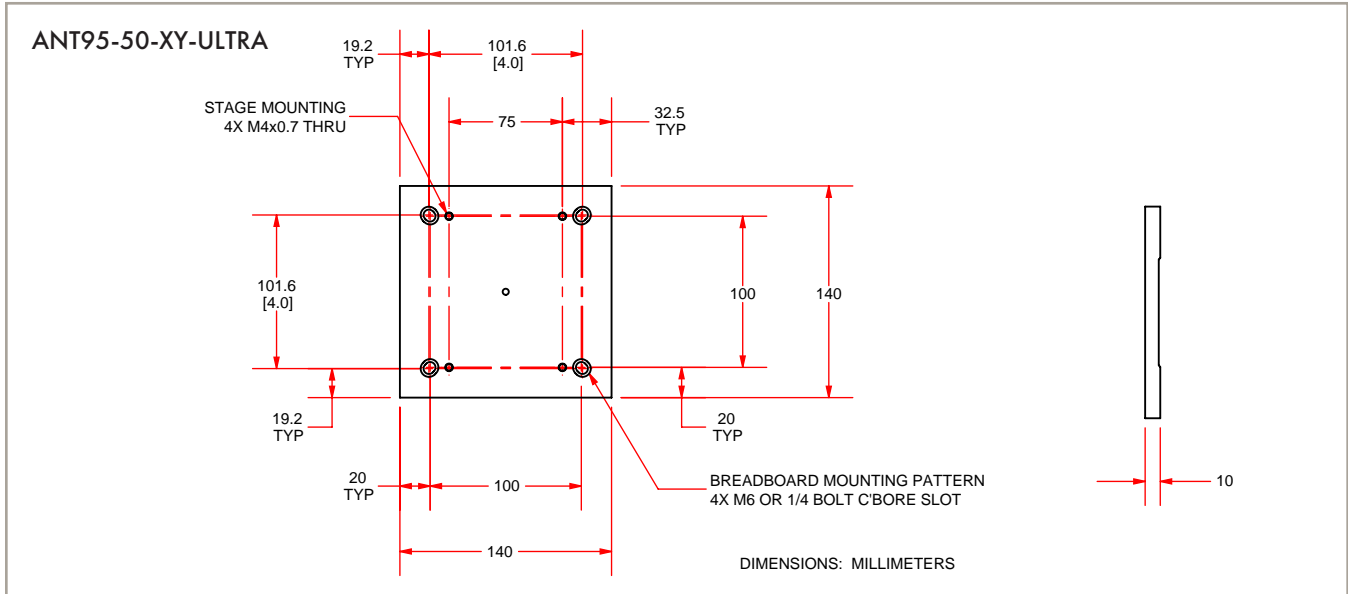
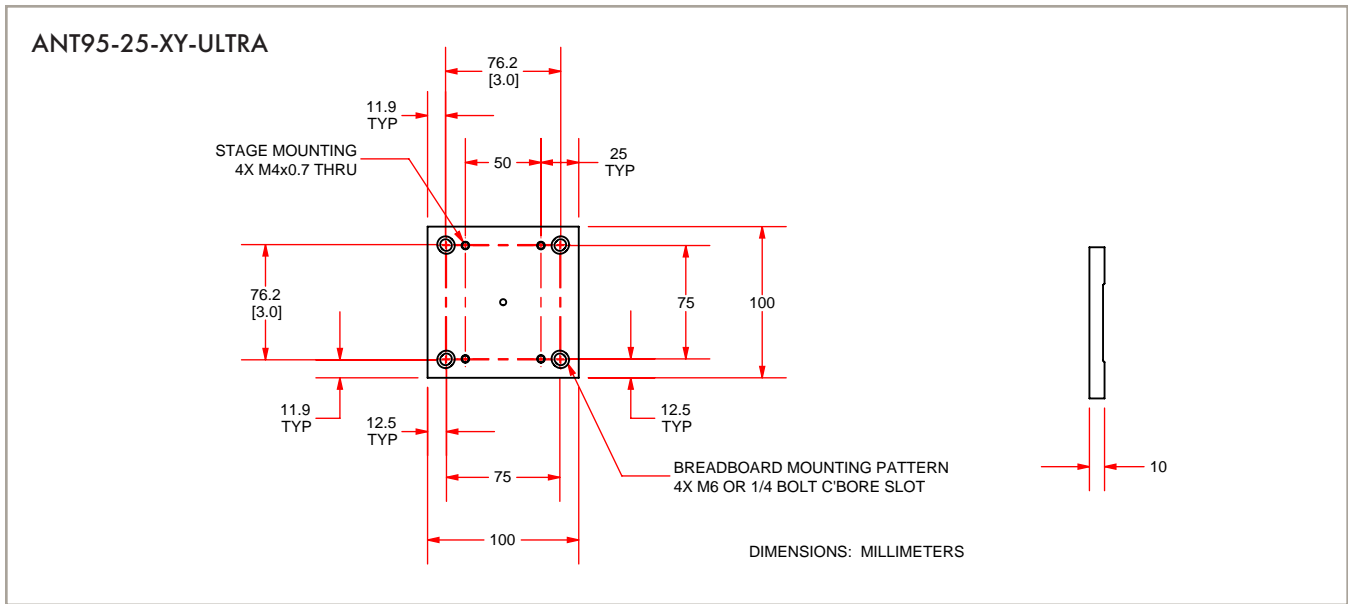

## ANT95-XY-ULTRA Series ORDERING INFORMATION

### ANT95-XY-ULTRA Series Linear Stage

ANT95-XY-ULTRA Aerotech nanotranslation crossed-roller linear positioner with 2D calibration

### Linear Stage Travel

ANT95-25-XY-ULTRA 25 mm (1 in) XY travel stage with proprietary direct-drive motor technology, 1 V<sub>p-p</sub> sinusoidal output linear encoder, and limits

ANT95-50-XY-ULTRA 50 mm (2 in) XY travel stage with proprietary direct-drive motor technology, 1 V<sub>p-p</sub> sinusoidal output linear encoder, and limits

### Options

-MP Breadboard mounting plate

# ANT130-L Series

## Single-Axis Linear Direct-Drive Nanopositioning Stages

Nanometer-level performance in a large travel format

High resolution (1 nm), repeatability (75 nm), and accuracy (250 nm)

In-position stability of <math><1\text{ nm}</math>

Anti-creep crossed-roller bearings

High dynamic performance

Large selection – 8 models in travel and accuracy

nano Motion Technology

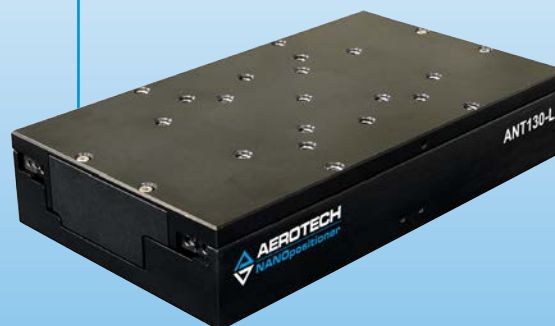

### Introduction

The ANT130-L series stages offer nanometer-level performance in travels up to 160 mm. With its low profile and outstanding performance characteristics, the ANT130-L is the ultimate solution for high-accuracy alignment, inspection, positioning, and measurement stations.

### Noncontact Direct-Drive

The linear motor drive also offers the advantage of higher speeds and accelerations. The compact yet powerful linear motor drives the ANT130-L to a peak unloaded acceleration of 1 g and a maximum velocity of 350 mm/s. The result is a high-accuracy device with outstanding throughput that significantly outperforms comparable high-accuracy screw-driven or other stages in its class.

### Outstanding Resolution

For alignment applications, outstanding step-to-step resolution is critical. The ANT130-L meets this demand with an incremental step size of 1 nm when coupled with Aerotech drives and controls. The direct-drive linear motor allows the ANT130-L to make precise, small resolution steps. This is particularly important in alignment applications where step accuracy is critical.

### Designed for Long Life

Like all stages in the Aerotech product family, the ANT130-L was designed for outstanding long-term performance. Both

the linear motor and linear encoder are noncontact devices, which means they not only exhibit long-life but are totally maintenance free.

### Precision Alignment

ANT130-L series stages are easily configured as XY assemblies. Options include precision orthogonality alignment to 5 arc seconds and vertical axis solutions.

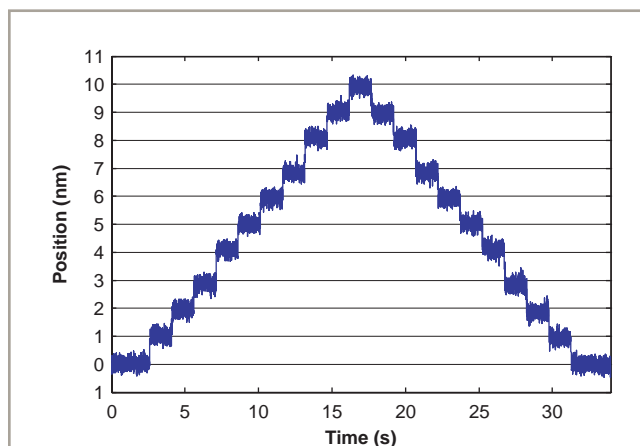

*ANT130-060-L-PLUS 1 nm step plot with 100 Hz filter. These stages offer best-in-class resolution and exceptional in-position stability for large travels.*

## ANT130-L/ANT130-L-PLUS Series SPECIFICATIONS

Mechanical Specifications	ANT130-035-L	ANT130-035-L-PLUS	ANT130-060-L	ANT130-060-L-PLUS
Travel	35 mm	35 mm	60 mm	60 mm
Accuracy <sup>(1)</sup>	±2 µm (±80 µin)	±250 nm (±10 µin)	±2 µm (±80 µin)	±250 nm (±10 µin)
Resolution	1 nm (0.04 µin)	1 nm (0.04 µin)	1 nm (0.04 µin)	1 nm (0.04 µin)
Repeatability (Bi-Directional) <sup>(1)</sup>	±100 nm (±4 µin)	±75 nm (±3 µin)	±100 nm (±4 µin)	±75 nm (±3 µin)
Repeatability (Uni-Directional)	±25 nm (±1 µin)	±25 nm (±1 µin)	±25 nm (±1 µin)	±25 nm (±1 µin)
Straightness <sup>(1)</sup>	±1.0 µm (±40 µin)	±1.0 µm (±40 µin)	±1.0 µm (±40 µin)	±1.0 µm (±40 µin)
Flatness <sup>(1)</sup>	±1.0 µm (±40 µin)	±1.0 µm (±40 µin)	±1.0 µm (±40 µin)	±1.0 µm (±40 µin)
Pitch	10 arc sec	10 arc sec	10 arc sec	10 arc sec
Roll	10 arc sec	10 arc sec	10 arc sec	10 arc sec
Yaw	5 arc sec	5 arc sec	5 arc sec	5 arc sec
Maximum Speed	350 mm/s (14 in/s)	350 mm/s (14 in/s)	350 mm/s (14 in/s)	350 mm/s (14 in/s)
Maximum Acceleration	1 g - 10 m/s <sup>2</sup> (No Load)	1 g - 10 m/s <sup>2</sup> (No Load)	1 g - 10 m/s <sup>2</sup> (No Load)	1 g - 10 m/s <sup>2</sup> (No Load)
Speed Stability	See graph for typical performance			
Settling Time	See graph for typical performance			
In-Position Stability <sup>(2)</sup>	<1 nm (<0.04 µin)	<1 nm (<0.04 µin)	<1 nm (<0.04 µin)	<1 nm (<0.04 µin)
Maximum Force (Continuous)	23 N	23 N	23 N	23 N
Load Capacity <sup>(3)</sup>	Horizontal	12.0 kg (26.5 lb)	12.0 kg (26.5 lb)	12.0 kg (26.5 lb)
	Side	10 kg (22 lb)	10 kg (22 lb)	10 kg (22 lb)
Moving Mass	1.2 kg (2.6 lb)	1.2 kg (2.6 lb)	1.4 kg (3.1 lb)	1.4 kg (3.1 lb)
Stage Mass	2.1 kg (4.6 lb)	2.1 kg (4.6 lb)	2.5 kg (5.5 lb)	2.5 kg (5.5 lb)
Material	Aluminum Body/Black Hardcoat Finish			
MTBF (Mean Time Between Failure)	30,000 Hours			

## Notes:

1. Certified with each stage.

2. In-Position Jitter listing is 3 sigma value.

3. Axis orientation for on-axis loading is listed.

- Specifications are for single-axis systems measured 25 mm above the tabletop. Performance of combined multi-axis systems is payload and workpoint dependent. Consult factory for multi-axis or non-standard applications.
- -PLUS requires the use of an Aerotech controller.

Mechanical Specifications	ANT130-110-L	ANT130-110-L-PLUS	ANT130-160-L	ANT130-160-L-PLUS
Travel	110 mm	110 mm	160 mm	160 mm
Accuracy <sup>(1)</sup>	±3 µm (±120 µin)	±300 nm (±12 µin)	±4 µm (±160 µin)	±300 nm (±12 µin)
Resolution	1 nm (0.04 µin)	1 nm (0.04 µin)	1 nm (0.04 µin)	1 nm (0.04 µin)
Repeatability (Bi-Directional) <sup>(1)</sup>	±100 nm (±4 µin)	±75 nm (±3 µin)	±100 nm (±4 µin)	±75 nm (±3 µin)
Repeatability (Uni-Directional)	±25 nm (±1 µin)	±25 nm (±1 µin)	±25 nm (±1 µin)	±25 nm (±1 µin)
Straightness <sup>(1)</sup>	±1.0 µm (±40 µin)	±1.0 µm (±40 µin)	±1.5 µm (±60 µin)	±1.5 µm (±60 µin)
Flatness <sup>(1)</sup>	±1.0 µm (±40 µin)	±1.0 µm (±40 µin)	±1.5 µm (±60 µin)	±1.5 µm (±60 µin)
Pitch	10 arc sec	10 arc sec	10 arc sec	10 arc sec
Roll	10 arc sec	10 arc sec	10 arc sec	10 arc sec
Yaw	5 arc sec	5 arc sec	5 arc sec	5 arc sec
Maximum Speed	350 mm/s (14 in/s)	350 mm/s (14 in/s)	350 mm/s (14 in/s)	350 mm/s (14 in/s)
Maximum Acceleration	1 g - 10 m/s <sup>2</sup> (No Load)	1 g - 10 m/s <sup>2</sup> (No Load)	1 g - 10 m/s <sup>2</sup> (No Load)	1 g - 10 m/s <sup>2</sup> (No Load)
Speed Stability	See graph for typical performance			
Settling Time	See graph for typical performance			
In-Position Stability <sup>(2)</sup>	<1 nm (<0.04 µin)	<1 nm (<0.04 µin)	<1 nm (<0.04 µin)	<1 nm (<0.04 µin)
Maximum Force (Continuous)	23 N	23 N	23 N	23 N
Load Capacity <sup>(3)</sup>	Horizontal	12.0 kg (26.5 lb)	12.0 kg (26.5 lb)	12.0 kg (26.5 lb)
	Side	10 kg (22 lb)	10 kg (22 lb)	10 kg (22 lb)
Moving Mass	1.9 kg (4.2 lb)	1.9 kg (4.2 lb)	2.3 kg (5.1 lb)	2.3 kg (5.1 lb)
Stage Mass	3.3 kg (7.3 lb)	3.3 kg (7.3 lb)	3.9 kg (8.6 lb)	3.9 kg (8.6 lb)
Material	Aluminum Body/Black Hardcoat Finish			
MTBF (Mean Time Between Failure)	30,000 Hours			

## Notes:

1. Certified with each stage.

2. In-Position Jitter listing is 3 sigma value.

3. Axis orientation for on-axis loading is listed.

- Specifications are for single-axis systems measured 25 mm above the tabletop. Performance of combined multi-axis systems is payload and workpoint dependent. Consult factory for multi-axis or non-standard applications.
- -PLUS requires the use of an Aerotech controller.

## ANT130-L/ANT130-L-PLUS Series SPECIFICATIONS

Electrical Specifications	ANT130-035-L ANT130-035-L-PLUS	ANT130-060-L ANT130-060-L-PLUS	ANT130-110-L ANT130-110-L-PLUS	ANT130-160-L ANT130-160-L-PLUS
Drive System	Brushless Linear Servomotor			
Feedback	Noncontact Linear Encoder			
Maximum Bus Voltage	±40 VDC			
Limit Switches	5 V, Normally Closed			
Home Switch	Near Center			

Recommended Controller	ANT130-035-L ANT130-035-L-PLUS	ANT130-060-L ANT130-060-L-PLUS	ANT130-110-L ANT130-110-L-PLUS	ANT130-160-L ANT130-160-L-PLUS
Multi-Axis	A3200	Npaq-MXR Npaq MR-MXH Ndrive ML-MXH		
	Ensemble	Epaq-MXH Epaq MR-MXH Ensemble ML-MXH		
Single Axis	Soloist	Soloist ML-MXH		

Notes:

1. Linear amplifiers are required to achieve the listed specifications. Other options are available.

Note: To ensure the achievement and repeatability of specifications over an extended period of time, environmental temperature must be controlled to within 0.25°C/24 hours. If this is not possible, alternate products are available. Please consult Aerotech Application Engineering for more information.

## ANT130-L/ANT130-L-PLUS Series PERFORMANCE

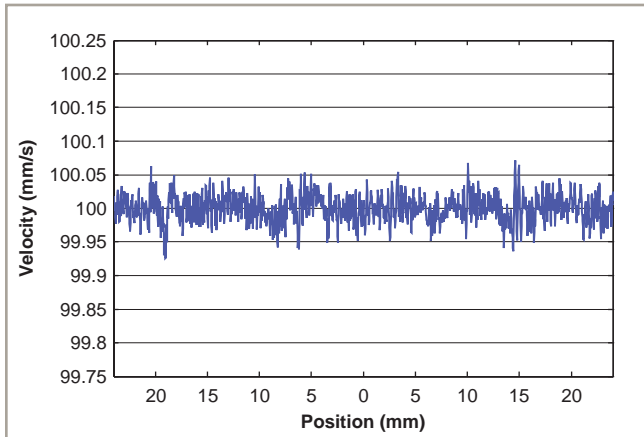

*ANT130-060-L-PLUS velocity performance at 100 mm/s and 1 kg payload. Excellent speed stability is another feature of the ANT series stages.*

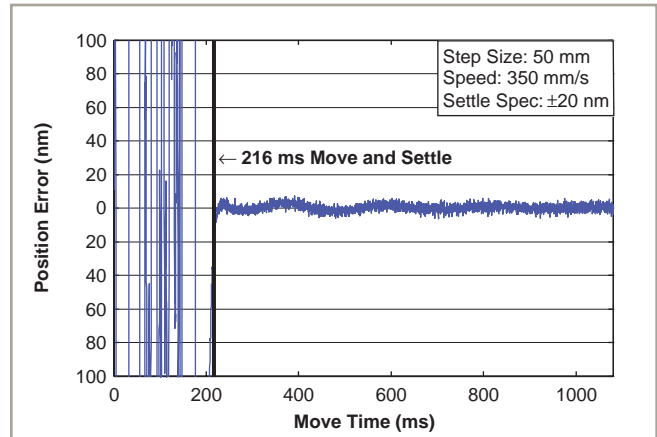

*ANT130-060-L-PLUS step and settle performance with 1 kg payload. Outstanding settling time enhances throughput of most applications.*

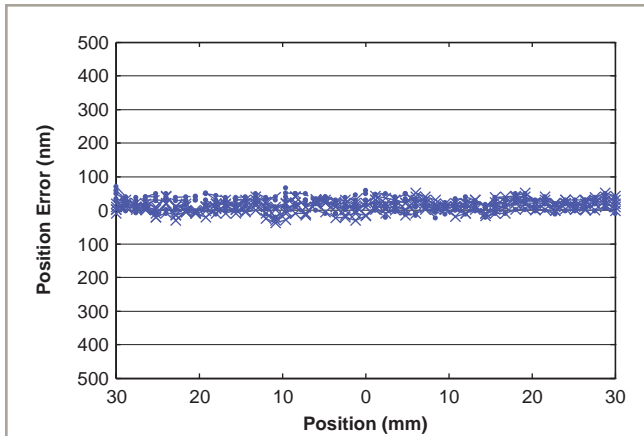

*ANT130-060-L-PLUS accuracy and repeatability, five runs, bi-directional over an extended period of time shows the high level of system accuracy and repeatability.*

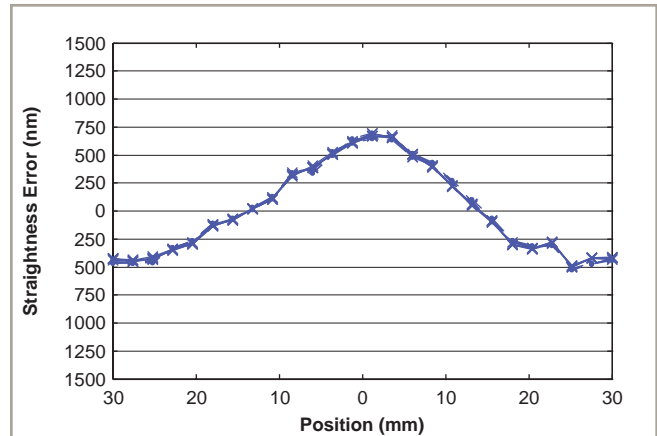

*ANT130-060-L-PLUS straightness error, bi-directional. Exceptional and highly repeatable performance is assured with minimal straightness error.*

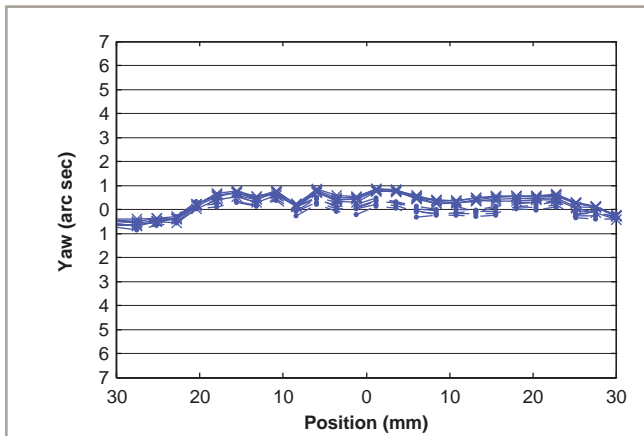

*ANT130-060-L-PLUS yaw, five runs, bi-directional. Highly repeatable, minimal yaw error enhances system positioning accuracy.*

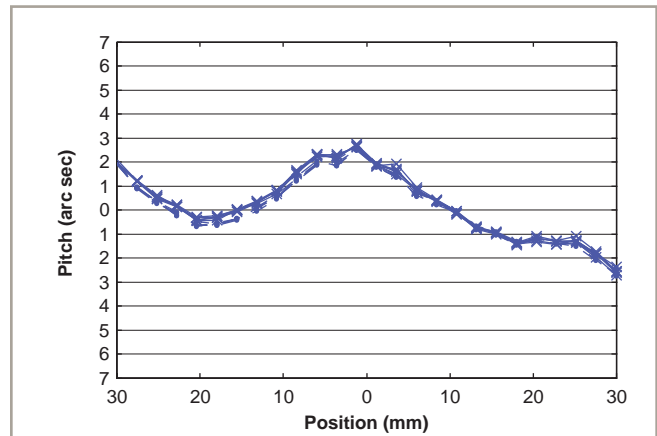

*ANT130-060-L-PLUS pitch, five runs, bi-directional. Excellent repeatability/accuracy contribute to improved processing.*

# ANT130-L/ANT130-L-PLUS DIMENSIONS

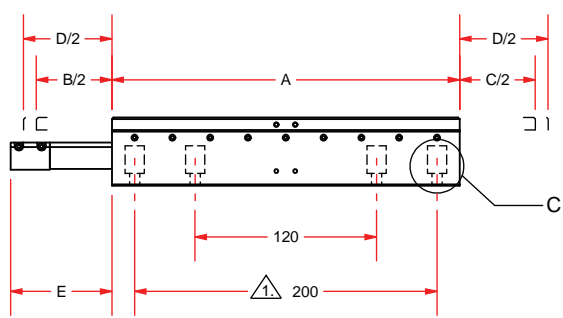
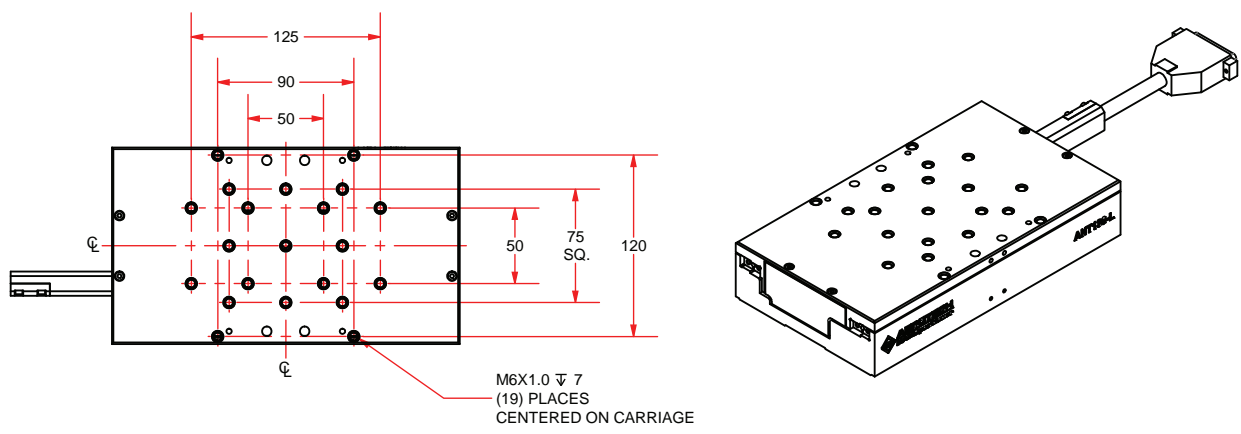

$\triangle$  ANT130-110-L AND ANT130-160-L ONLY

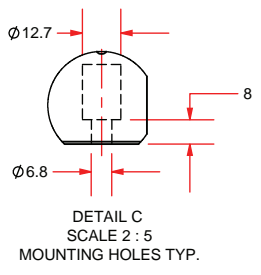
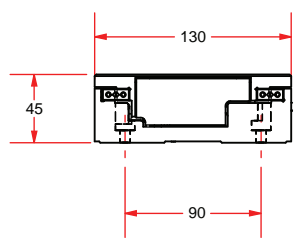

MODEL	A = STAGE LENGTH	B = NOMINAL TRAVEL	C = LIMIT TRAVEL	D = HARDSTOP TRAVEL	E
ANT130-035-L	155	35	41	50	27
ANT130-060-L	180	60	66	75	42
ANT130-110-L	230	110	116	125	67
ANT130-160-L	280	160	166	175	92

DIMENSIONS: MILLIMETERS

# ANT130-L/ANT130-L-PLUS Mounting Plate DIMENSIONS

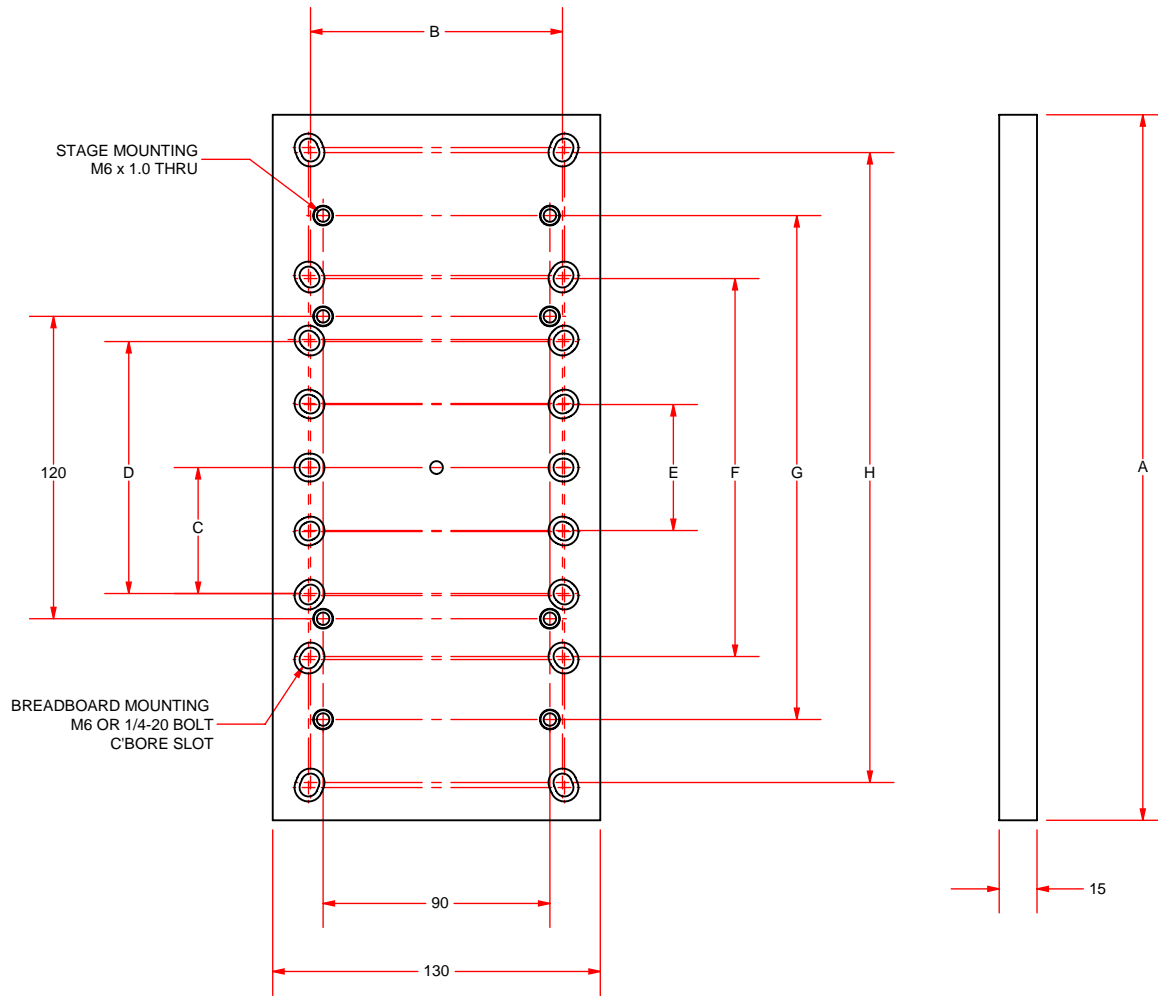

OPTION	LENGTH	MOUNTING						
	A	B	C	D	E	F	G	H
MP-ANT130-035	155	100[4.0]	50[2.0]	100[4.0]	--	--	--	--
MP-ANT130-060	180	100[4.0]	--	--	50[2.0]	150[6.0]	--	--
MP-ANT130-110	230	100[4.0]	--	--	50[2.0]	150[6.0]	200	--
MP-ANT130-160	280	100[4.0]	--	--	50[2.0]	150[6.0]	200	250[10.0]

DIMENSIONS: MILLIMETERS



## ANT130-L/ANT130-L-PLUS Series ORDERING INFORMATION

### ANT130-L Series Linear Stage

ANT130-L/ANT130-L-PLUS	Aerotech nanotranslation crossed-roller linear positioner
------------------------	---

#### Linear Stage Travel

ANT130-035-L	35 mm travel stage with linear motor and limits
ANT130-035-L-PLUS	35 mm travel stage with linear motor and limits (high accuracy version)
ANT130-060-L	60 mm travel stage with linear motor and limits
ANT130-060-L-PLUS	60 mm travel stage with linear motor and limits (high accuracy version)
ANT130-110-L	110 mm travel stage with linear motor and limits
ANT130-110-L-PLUS	110 mm travel stage with linear motor and limits (high accuracy version)
ANT130-160-L	160 mm travel stage with linear motor and limits
ANT130-160-L-PLUS	160 mm travel stage with linear motor and limits (high accuracy version)

#### Output Cable Connectors

-25DU	Single 25-pin D connector (standard)
-4DU-25DU	4-pin HPD and 25-pin D connectors

Note: -25DU single 25-pin connector option not valid for systems using bus voltages greater than 80 V

#### Options

-MP	Breadboard mounting plate
-----	---------------------------

# ANT130-XY Series

## Two-Axis XY Direct-Drive Nanopositioning Stages

Integrated low-profile XY linear motor stage

Nanometer-level performance in a large travel format

High resolution (1 nm), repeatability (75 nm), and accuracy (250 nm) per axis

In-position stability of <1 nm

Anti-creep crossed-roller bearings

High dynamic performance

nano Motion Technology

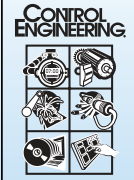

2011  
ENGINEERS'  
CHOICE  
AWARDS



### Introduction

The ANT130-XY series stages offer nanometer-level performance in travels up to 160 mm. The ANT130-XY and ANT130-XY-PLUS are three-piece designs that allow travel in two dimensions (X and Y). The sleek design provides an extremely low profile of only 85 mm. The stage comes with proprietary direct-drive motor technology, noncontact linear encoders, limits, integrated cable management system, and two grades of accuracy.

### Stage Design

The ANT130-XY design allows critical elements such as orthogonality, straightness, and flatness to be optimized, resulting in a stage with exceptional geometrical tolerances. Aerotech's direct-drive technology has no hysteresis or backlash, enabling accurate and repeatable nanometer-scale motion in both the X and Y dimensions. All travel options (60 mm x 60 mm, 110 mm x 110 mm, 160 mm x 160 mm) come with the 85 mm profile height. You can expect outstanding accuracy, position repeatability, and in-position stability with the ANT130-XY stage.

### Noncontact Direct-Drive

Only noncontact direct-drive technology offers the robust, accurate, and high-speed positioning necessary for mass production of precision devices. ANT130-XY stages utilize advanced direct-drive technology pioneered by Aerotech to achieve the highest level of positioning performance. This direct-drive technology is high-performance, non-cogging, noncontact, high-speed, high-resolution, and high-accuracy.

This unique drive and bearing combination, packaged in an extremely small-profile and footprint, offers tangible advantages in many applications such as high-precision positioning, disk-drive fabrication, fiber alignment, optical delay element actuation, sensor testing, and scanning processes that demand smooth and precise motion. The integrated cable management system is designed for long life and to minimize drag forces.

### Multi-Axis Configurations

The ANT130-XY can be combined with other Aerotech ANT series products (vertical lift stages, direct-drive rotaries, and goniometers) to create unique, high performance, multi-axis systems.

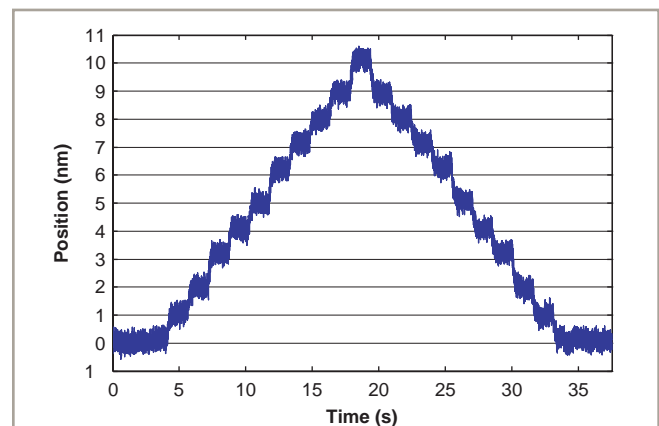

ANT130-160-XY-PLUS lower axis 1 nm step plot with 100 Hz filter. Best-in-class resolution and exceptional in-position stability for large travel stages.

## ANT130-XY/ANT130-XY-PLUS Series SPECIFICATIONS

Mechanical Specifications	ANT130-060-XY	ANT130-060-XY-PLUS	ANT130-110-XY	ANT130-110-XY-PLUS
<b>Travel</b>	60 mm	60 mm	110 mm	110 mm
<b>Accuracy<sup>(1)</sup></b>	±2.5 µm (±100 µin)	±250 nm (±10 µin)	±4.0 µm (±160 µin)	±300 nm (±12 µin)
<b>Resolution</b>	1 nm (0.04 µin)	1 nm (0.04 µin)	1 nm (0.04 µin)	1 nm (0.04 µin)
<b>Repeatability (Bi-Directional)<sup>(1)</sup></b>	±100 nm (±4 µin)	±75 nm (±3 µin)	±100 nm (±4 µin)	±75 nm (±3 µin)
<b>Repeatability (Uni-Directional)</b>	±25 nm (±1 µin)	±25 nm (±1 µin)	±25 nm (±1 µin)	±25 nm (±1 µin)
<b>Straightness<sup>(1)</sup></b>	±1.5 µm (±60 µin)	±1.5 µm (±60 µin)	±1.5 µm (±60 µin)	±1.5 µm (±60 µin)
<b>Flatness<sup>(1)</sup></b>	±1.5 µm (±60 µin)	±1.5 µm (±60 µin)	±1.5 µm (±60 µin)	±1.5 µm (±60 µin)
<b>Pitch</b>	10 arc sec	10 arc sec	12 arc sec	12 arc sec
<b>Roll</b>	10 arc sec	10 arc sec	12 arc sec	12 arc sec
<b>Yaw</b>	5 arc sec	5 arc sec	6 arc sec	6 arc sec
<b>Orthogonality</b>	10 arc sec	3 arc sec	10 arc sec	3 arc sec
<b>Maximum Speed</b>	350 mm/s (14 in/s) (Upper Axis)	350 mm/s (14 in/s) (Upper Axis)	350 mm/s (14 in/s) (Upper Axis)	350 mm/s (14 in/s) (Upper Axis)
<b>Maximum Acceleration</b>	1 g - 10 m/s <sup>2</sup> (No Load)(Upper Axis)	1 g - 10 m/s <sup>2</sup> (No Load)(Upper Axis)	1 g - 10 m/s <sup>2</sup> (No Load)(Upper Axis)	1 g - 10 m/s <sup>2</sup> (No Load)(Upper Axis)
<b>Speed Stability</b>	See graph for typical performance			
<b>Settling Time</b>	See graph for typical performance			
<b>In-Position Stability<sup>(2)</sup></b>	<1 nm (<0.04 µin)	<1 nm (<0.04 µin)	<1 nm (<0.04 µin)	<1 nm (<0.04 µin)
<b>Maximum Force (Continuous)</b>	23 N	23 N	23 N	23 N
<b>Load Capacity<sup>(3)</sup></b>	<b>Horizontal</b>	12.0 kg (26.5 lb)	12.0 kg (26.5 lb)	12.0 kg (26.5 lb)
<b>Moving Mass</b>	<b>Upper</b>	1.5 kg (3.3 lb)	1.5 kg (3.3 lb)	2.1 kg (4.6 lb)
	<b>Lower</b>	4.2 kg (9.2 lb)	4.2 kg (9.2 lb)	5.7 kg (12.5 lb)
<b>Stage Mass</b>	5.5 kg (12.1 lb)	5.5 kg (12.1 lb)	7.4 kg (16.3 lb)	7.4 kg (16.3 lb)
<b>Material</b>	Aluminum Body/Black Hardcoat Finish			
<b>MTBF (Mean Time Between Failure)</b>	30,000 Hours			

Notes:

1. Certified with each stage.

2. In-Position Jitter listing is 3 sigma value.

3. Axis orientation for on-axis loading is listed.

• Specifications are for XY systems measured 25 mm above the tabletop. Consult factory for multi-axis or non-standard applications.

• -PLUS requires the use of an Aerotech controller.

## ANT130-XY/ANT130-XY-PLUS Series SPECIFICATIONS

Mechanical Specifications		ANT130-160-XY	ANT130-160-XY-PLUS
Travel		160 mm	160 mm
Accuracy <sup>(1)</sup>		±5.0 µm (±200 µin)	±300 nm (±12 µin)
Resolution		1 nm (0.04 µin)	1 nm (0.04 µin)
Repeatability (Bi-Directional) <sup>(1)</sup>		±100 nm (±4 µin)	±75 nm (±3 µin)
Repeatability (Uni-Directional)		±25 nm (±1 µin)	±25 nm (±1 µin)
Straightness <sup>(1)</sup>		±2.0 µm (±80 µin)	±2.0 µm (±80 µin)
Flatness <sup>(1)</sup>		±2.0 µm (±80 µin)	±2.0 µm (±80 µin)
Pitch		15 arc sec	15 arc sec
Roll		15 arc sec	15 arc sec
Yaw		8 arc sec	8 arc sec
Orthogonality		10 arc sec	3 arc sec
Maximum Speed		350 mm/s (14 in/s) (Upper Axis)	350 mm/s (14 in/s) (Upper Axis)
Maximum Acceleration		1 g - 10 m/s <sup>2</sup> (No Load)(Upper Axis)	1 g - 10 m/s <sup>2</sup> (No Load)(Upper Axis)
Speed Stability		See graph for typical performance	
Settling Time		See graph for typical performance	
In-Position Stability <sup>(2)</sup>		<1 nm (<0.04 µin)	<1 nm (<0.04 µin)
Maximum Force (Continuous)		23 N	23 N
Load Capacity <sup>(3)</sup>	Horizontal	12.0 kg (26.5 lb)	12.0 kg (26.5 lb)
	Upper	2.4 kg (5.3 lb)	2.4 kg (5.3 lb)
Moving Mass	Lower	6.9 kg (15.2 lb)	6.9 kg (15.2 lb)
	Stage Mass	8.9 kg (19.6 lb)	8.9 kg (19.6 lb)
Material		Aluminum Body/Black Hardcoat Finish	
MTBF (Mean Time Between Failure)		30,000 Hours	

Notes:

- Certified with each stage.
  - In-Position Jitter listing is 3 sigma value.
  - Axis orientation for on-axis loading is listed.
- Specifications are for XY systems measured 25 mm above the tabletop. Consult factory for multi-axis or non-standard applications.
  - PLUS requires the use of an Aerotech controller.

Electrical Specifications	ANT130-060-XY ANT130-060-XY-PLUS	ANT130-110-XY ANT130-110-XY-PLUS	ANT130-160-XY ANT130-160-XY-PLUS
Drive System	Brushless Linear Servomotor		
Feedback	Noncontact Linear Encoder		
Maximum Bus Voltage	±40 VDC		
Limit Switches	5 V, Normally Closed		
Home Switch	Near Center		

Recommended Controller	ANT130-060-XY ANT130-060-XY-PLUS	ANT130-110-XY ANT130-110-XY-PLUS	ANT130-160-XY ANT130-160-XY-PLUS
Multi-Axis	A3200	Npaq-MXR Npaq MR-MXH Ndrive ML-MXH	
	Ensemble	Epaq-MXH Epaq MR-MXH Ensemble ML-MXH	
Single Axis	Soloist	Soloist ML-MXH	

Notes:

- Linear amplifiers are required to achieve the listed specifications. Other options are available.

Note: To ensure the achievement and repeatability of specifications over an extended period of time, environmental temperature must be controlled to within 0.25°C/24 hours. If this is not possible, alternate products are available. Please consult Aerotech Application Engineering for more information.

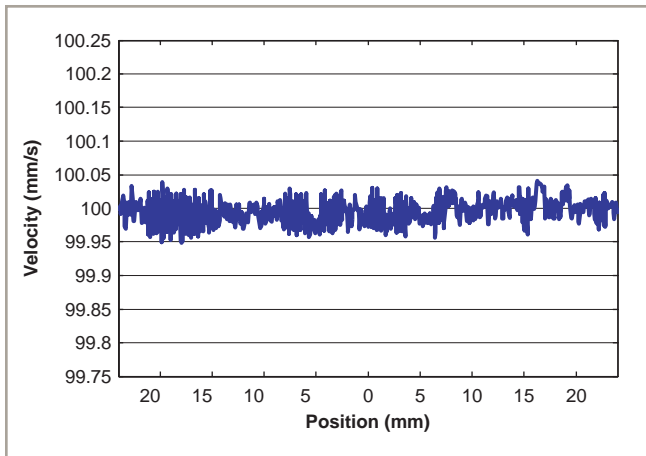

ANT130-060-XY-PLUS velocity performance at 100 mm/s and 1 kg payload for the X (lower) axis. This outstanding speed stability enhances most scanning or laser machining applications.

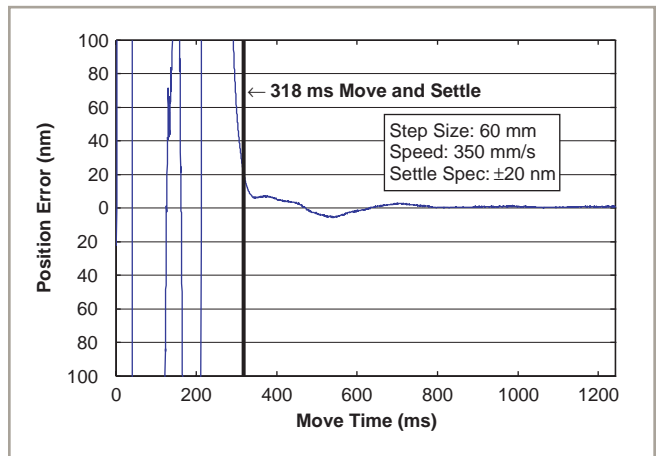

ANT130-060-XY-PLUS step and settle performance at full travel and 1 kg payload for the X (lower) axis. Industry-best settling times significantly improve throughput for most applications.

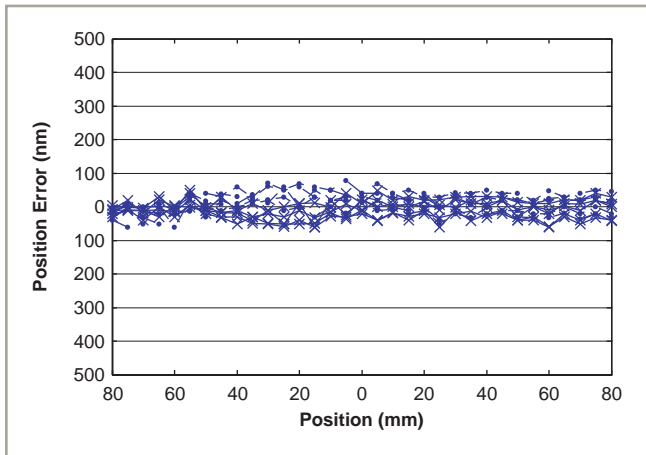

ANT130-160-XY-PLUS accuracy and repeatability, five runs, bi-directional for the Y (upper) axis. The total accuracy of  $\pm 75$  nm over 160 mm travel is significantly better than other offerings.

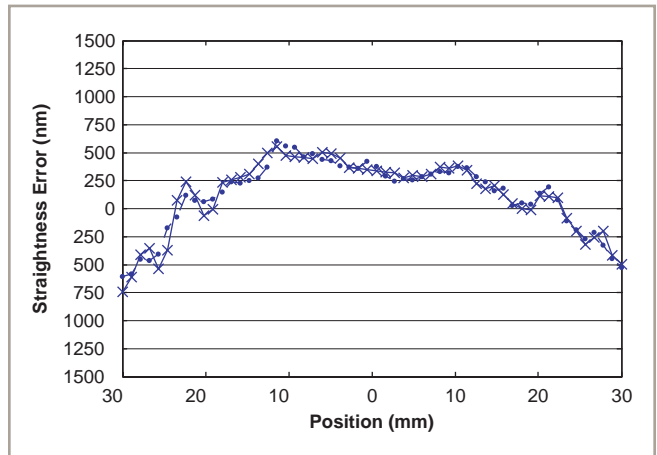

ANT130-060-XY-PLUS bi-directional straightness error for the Y (upper) axis. Significantly (five times) better than stated specification.

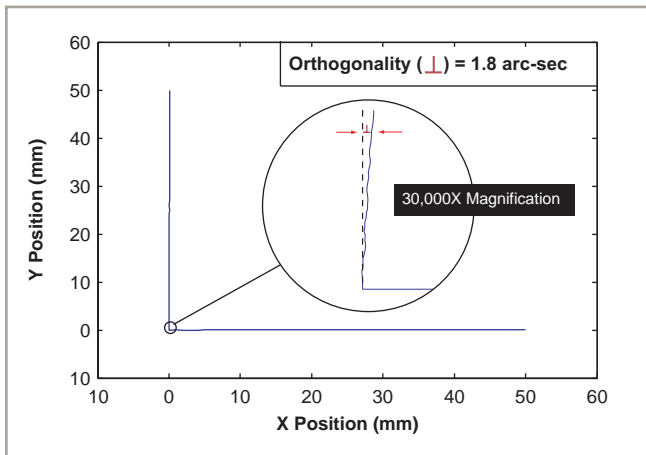

ANT130-060-XY-PLUS orthogonality. The inset is exaggerated 30,000X for clarity. Exceptionally small angular (orthogonality) error significantly enhances system accuracy.

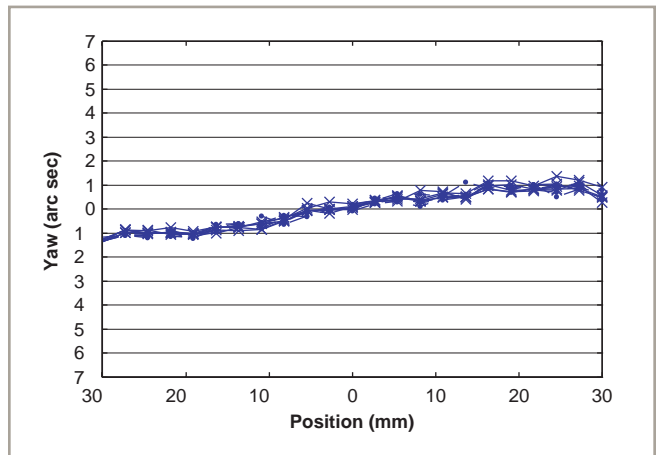

ANT130-060-XY-PLUS Y (upper) axis yaw, five runs, bi-directional. Highly repeatable, lowest angular error over full travel.

ANT130-XY/ANT130-XY-PLUS DIMENSIONS

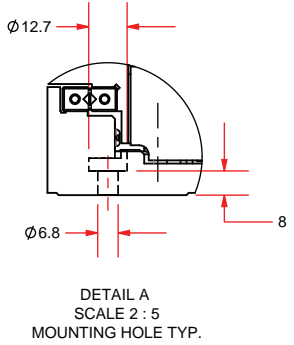
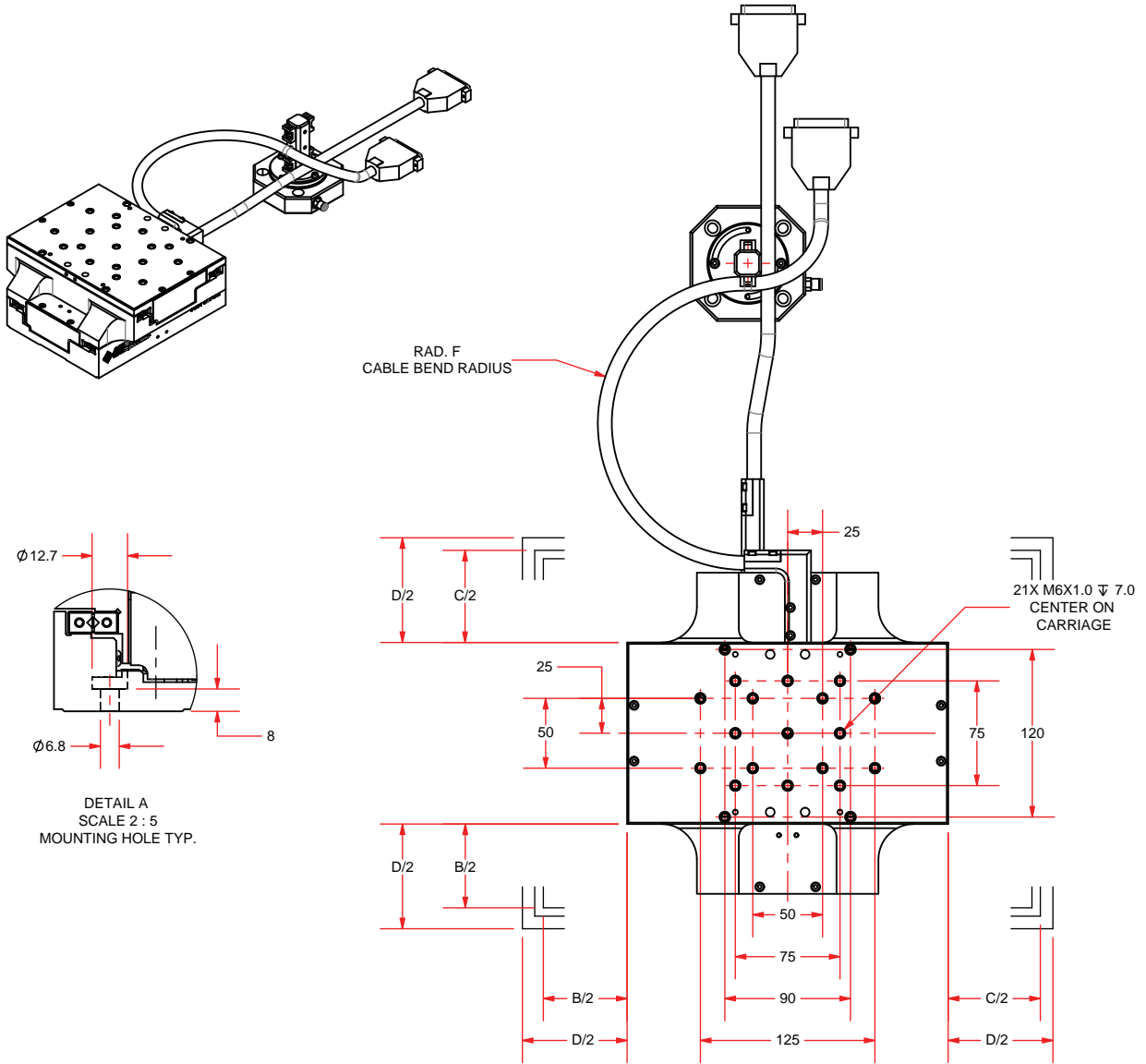

MODEL	A = STAGE LENGTH	B = NOMINAL TRAVEL	C = LIMIT TRAVEL	D = HARDSTOP TRAVEL	E	F
ANT130-060-XY	180	60 X 60	66 X 66	75 X 75	42	-87.5
ANT130-110-XY	230	110 X 110	116 X 116	125 X 125	67	-100
ANT130-160-XY	280	160 X 160	166 X 166	175 X 175	92	-112.5

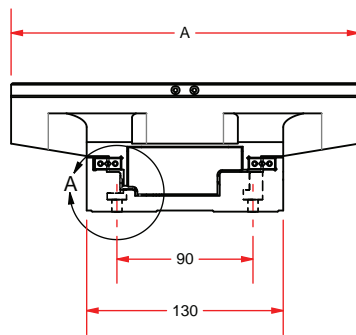
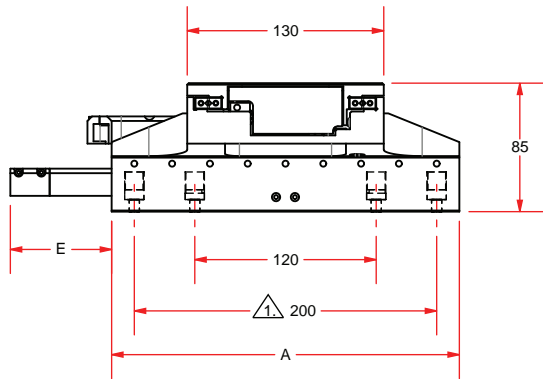

△ ANT130-110-XY AND ANT130-160-XY ONLY

DIMENSIONS: MILLIMETERS

# ANT130-XY/ANT130-XY-PLUS Mounting Plate DIMENSIONS

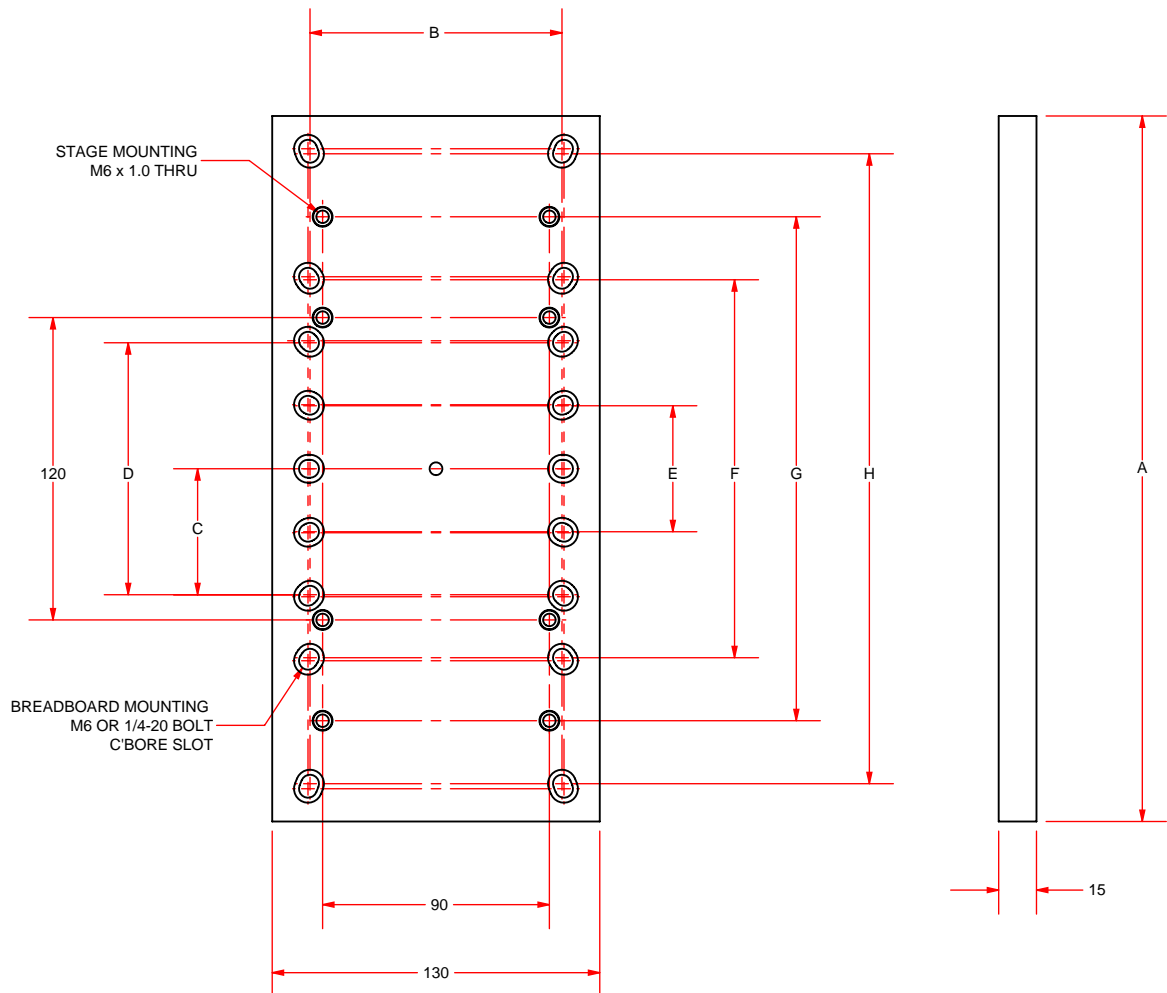

OPTION	LENGTH		MOUNTING					
	A	B	C	D	E	F	G	H
MP-ANT130-035	155	100[4.0]	50[2.0]	100[4.0]	--	--	--	--
MP-ANT130-060	180	100[4.0]	--	--	50[2.0]	150[6.0]	--	--
MP-ANT130-110	230	100[4.0]	--	--	50[2.0]	150[6.0]	200	--
MP-ANT130-160	280	100[4.0]	--	--	50[2.0]	150[6.0]	200	250[10.0]

DIMENSIONS: MILLIMETERS



ANT130-XY/ANT130-XY-PLUS CMS Post DIMENSIONS

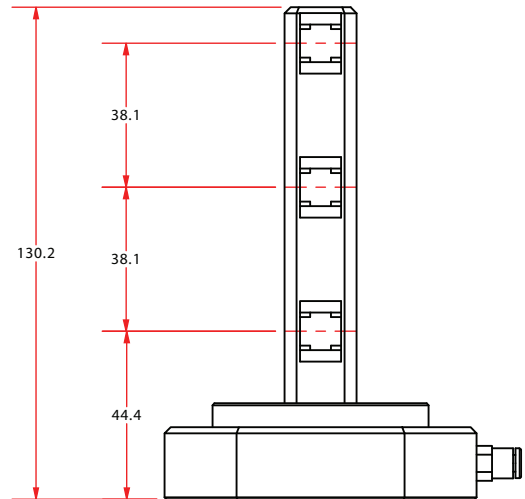
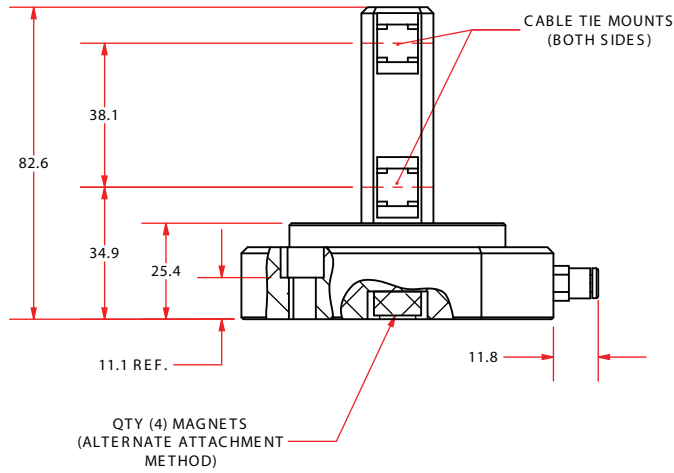
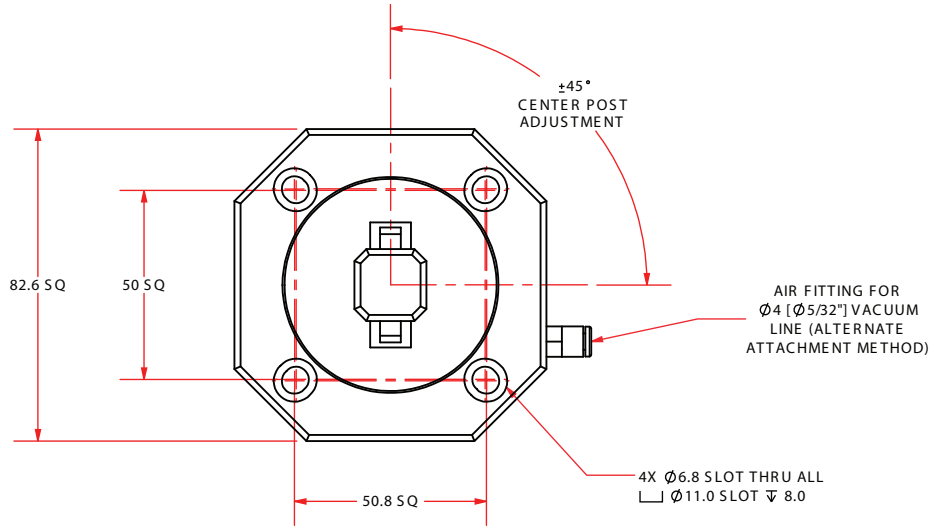

ACP3: INCLUDED WITH  
"-XYZ-CMS" OPTION  
NOTE: DIMENSIONS NOT SHOWN  
ARE THE SAME AS ACP2

ACP2: INCLUDED WITH  
"-XY-CMS" OPTION

DIMENSIONS: MILLIMETERS

## ANT130-XY/ANT130-XY-PLUS Series ORDERING INFORMATION

### ANT130-XY Series Linear Stage

ANT130-XY/ANT130-XY-PLUS Aerotech nanotranslation crossed-roller linear positioner

#### Linear Stage Travel

ANT130-060-XY	60 mm travel XY stage with linear motor and limits
ANT130-060-XY-PLUS	60 mm travel XY stage with linear motor and limits (high accuracy version)
ANT130-110-XY	110 mm travel XY stage with linear motor and limits
ANT130-110-XY-PLUS	110 mm travel XY stage with linear motor and limits (high accuracy version)
ANT130-160-XY	160 mm travel XY stage with linear motor and limits
ANT130-160-XY-PLUS	160 mm travel XY stage with linear motor and limits (high accuracy version)

#### Output Cable Connectors

-25DU	Single 25-pin D connector (standard)
-4DU-25DU	4-pin HPD and 25-pin D connectors

Note: -25DU single 25-pin connector option not valid for systems using bus voltages greater than 80 V

#### CMS Post

-XY-CMS	Post for two-axis cable anchoring (ACP2 – see product drawing)
-XYZ-CMS	Post for three-axis cable anchoring (ACP3 – see product drawing)

#### Options

-MP	Breadboard mounting plate
-----	---------------------------

# ANT130-XY-ULTRA

## Two-Axis XY Direct-Drive Nanopositioning Stages

Integrated low-profile XY linear motor stage

Nanometer-level performance in a large travel format

2D system accuracy is 250 nm

In-position stability of <1 nm

High dynamic performance

nano Motion Technology



### Introduction

Aerotech's ANT130-XY-ULTRA is a long travel (up to 160 mm x 160 mm) nanopositioner for XY applications. Each axis uses crossed-roller bearings, as well as Aerotech's unique direct-drive for non-cogging, zero backlash motion. In addition, each stage receives a two-dimensional correction to achieve unmatched nanometer resolution, accuracy, and repeatability. This unique drive and bearing combination, packaged in an extremely low profile and small footprint, offers tangible advantages in your motion application.

The ANT130-XY-ULTRA extends the performance capability of Aerotech's ANT130-XY stage series to levels found nowhere else. The exceptional geometric and dynamic performance of the ANT130-XY-ULTRA make it an ideal choice for nearly all high-end motion applications in the lab or in production environments.

### ULTRA Trajectory Management System

In order to achieve the highest possible system accuracy from our multi-axis nanopositioning systems, Aerotech has developed an advanced, interactive, dynamic trajectory management system. To take advantage of this sophisticated interactive calibration system, the mechanical system has to be completely assembled and functionally tested prior to calibration in our best-in-class metrology labs. Nano-level system accuracy can only be achieved under stringent environmental conditions, calibrating with the best test equipment, and utilizing the formidable capability of ULTIMUS. By implementing the ULTIMUS dynamic trajectory management system with the ANT130-XY-ULTRA, we are able to produce 2-dimensional accuracies of  $\pm 250$  nm or better.

The plots below illustrate performance differences between a standard ANT130-XY and the -ULTRA version. Straightness errors, orthogonality errors, and accuracy errors caused by stage yawing are virtually eliminated.

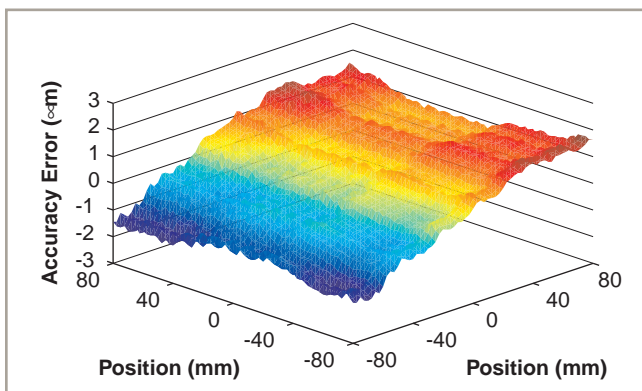

ANT130-160-XY 2D accuracy plot showing planar accuracy error including straightness, orthogonality, and stage yawing.

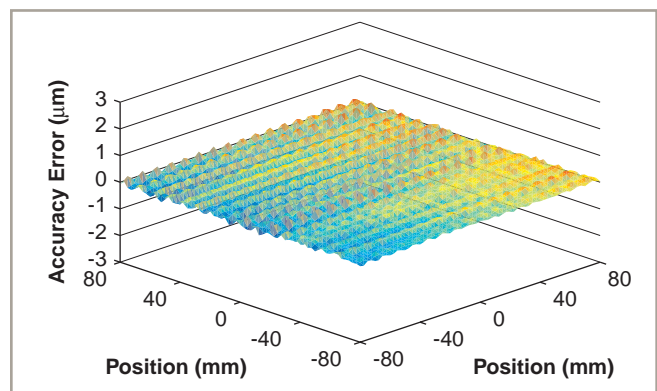

ANT130-160-XY-ULTRA – exceptional 2D system accuracy with Aerotech's ULTRA version.

# ANT130-XY-ULTRA Series SPECIFICATIONS

Mechanical Specifications	ANT130-060-XY-ULTRA	ANT130-110-XY-ULTRA	ANT130-160-XY-ULTRA
Travel	60 mm	110 mm	160 mm
2D Accuracy <sup>(1)</sup>	±250 nm (±10 µin)	±300 nm (±12 µin)	±300 nm (±12 µin)
Resolution	1 nm (0.04 µin)	1 nm (0.04 µin)	1 nm (0.04 µin)
Repeatability (Bi-Directional) <sup>(4)</sup>	±75 nm (±3 µin)	±75 nm (±3 µin)	±75 nm (±3 µin)
Repeatability (Uni-Directional)	±25 nm (±1 µin)	±25 nm (±1 µin)	±25 nm (±1 µin)
Straightness <sup>(1)</sup>	±250 nm (±10 µin)	±300 nm (±12 µin)	±300 nm (±12 µin)
Flatness <sup>(1)</sup>	±1.0 µm (±40 µin)	±1.0 µm (±40 µin)	±1.0 µm (±40 µin)
Pitch	10 arc sec	12 arc sec	12 arc sec
Roll	10 arc sec	12 arc sec	12 arc sec
Yaw	5 arc sec	6 arc sec	6 arc sec
Orthogonality	1.0 arc sec	0.5 arc sec	0.5 arc sec
Maximum Speed	350 mm/s (14 in/s) (Upper Axis)	350 mm/s (14 in/s) (Upper Axis)	350 mm/s (14 in/s) (Upper Axis)
Maximum Acceleration	1 g - 10 m/s <sup>2</sup> (No Load)(Upper Axis)	1 g - 10 m/s <sup>2</sup> (No Load)(Upper Axis)	1 g - 10 m/s <sup>2</sup> (No Load)(Upper Axis)
Speed Stability	See graph for typical performance		
Settling Time	See graph for typical performance		
In-Position Stability <sup>(2)</sup>	<1 nm (<0.04 µin)	<1 nm (<0.04 µin)	<1 nm (<0.04 µin)
Maximum Force (Continuous)	23 N	23 N	23 N
Load Capacity <sup>(3)</sup>	Horizontal	12.0 kg (26.5 lb)	12.0 kg (26.5 lb)
	Upper	1.5 kg (3.3 lb)	2.1 kg (4.6 lb)
Moving Mass	Lower	4.2 kg (9.2 lb)	5.7 kg (12.5 lb)
	Stage Mass	5.5 kg (12.1 lb)	7.4 kg (16.3 lb)
Material	Aluminum Body/Black Hardcoat Finish		
MTBF (Mean Time Between Failure)	30,000 Hours		

Notes:

1. Certified with each stage.
2. In-Position Jitter listing is 3 sigma value.
3. Axis orientation for on-axis loading is listed.
- Specifications are for XY systems measured 25 mm above the tabletop. Consult factory for multi-axis or non-standard applications.
- -ULTRA requires the use of an Aerotech controller.

Electrical Specifications	ANT130-060-XY-ULTRA	ANT130-110-XY-ULTRA	ANT130-160-XY-ULTRA
Drive System	Brushless Linear Servomotor		
Feedback	Noncontact Linear Encoder		
Maximum Bus Voltage	±40 VDC		
Limit Switches	5 V, Normally Closed		
Home Switch	Near Center		

Recommended Controller	ANT130-060-XY-ULTRA	ANT130-110-XY-ULTRA	ANT130-160-XY-ULTRA
Multi-Axis	A3200	Npaq-MXR Npaq MR-MXH Ndrive ML-MXH	
	Ensemble	Epaq-MXH Epaq MR-MXH Ensemble ML-MXH	
Single Axis	Soloist	Soloist ML-MXH	

Notes:

1. Linear amplifiers are required to achieve the listed specifications. Other options are available.

Note: To ensure the achievement and repeatability of specifications over an extended period of time, environmental temperature must be controlled to within 0.25°C/24 hours. If this is not possible, alternate products are available. Please consult Aerotech Application Engineering for more information.

## ANTI130-XY-ULTRA Series PERFORMANCE

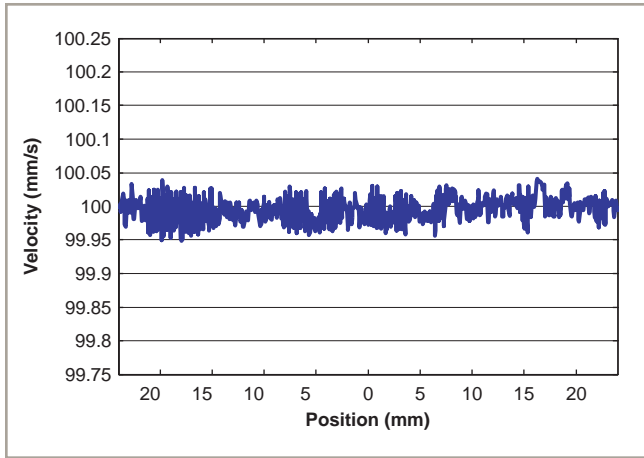

ANTI130-060-XY-ULTRA velocity performance at 100 mm/s and 1 kg payload for the X (lower) axis. This outstanding speed stability enhances most scanning or laser machining applications.

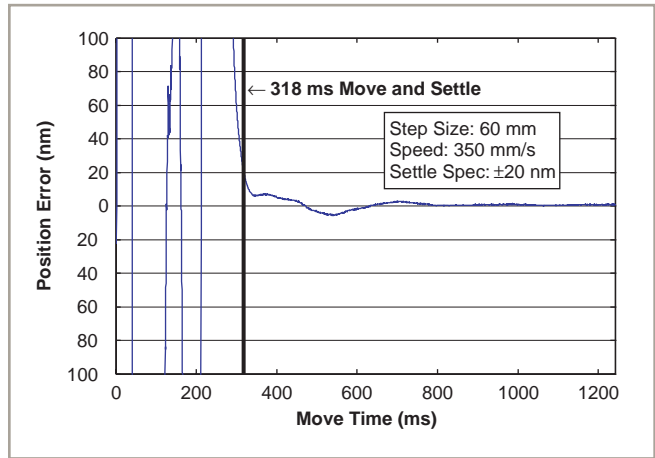

ANTI130-060-XY-ULTRA step and settle performance at full travel and 1 kg payload for the X (lower) axis. Industry-best settling times significantly improve throughput for most applications.

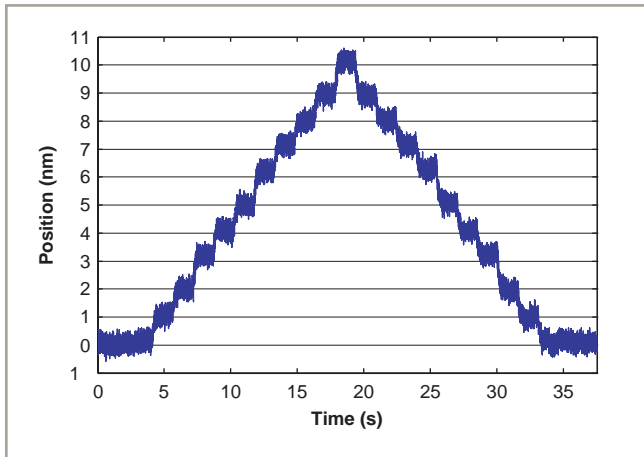

ANTI130-060-XY-ULTRA lower axis 1 nm step plot. Best-in-class resolution and exceptional in-position stability for large travel stages.

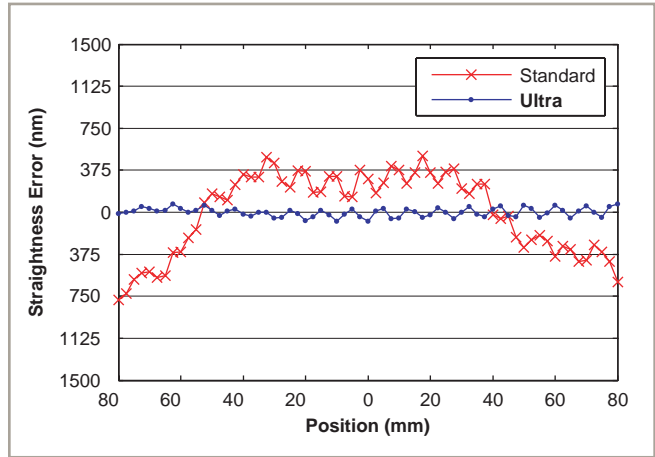

ANTI130-160-XY straightness error comparison between the BASE and ULTRA models shows a dramatic improvement in this specification.

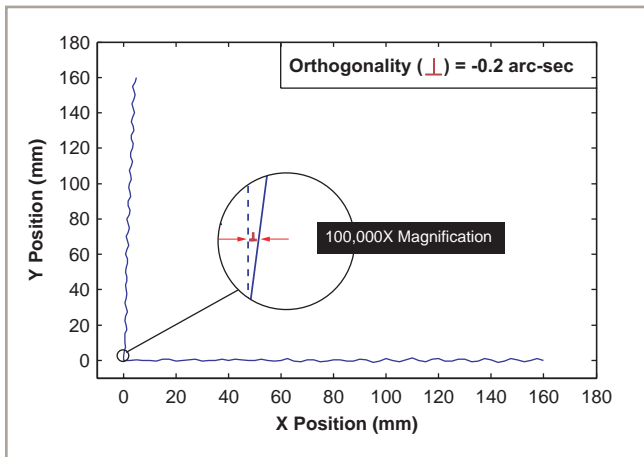

ANTI130-060-XY-ULTRA orthogonality. The inset is magnified 100,000X for clarity. The ULTRA model orthogonality is a twenty-fold improvement over the BASE model orthogonality.

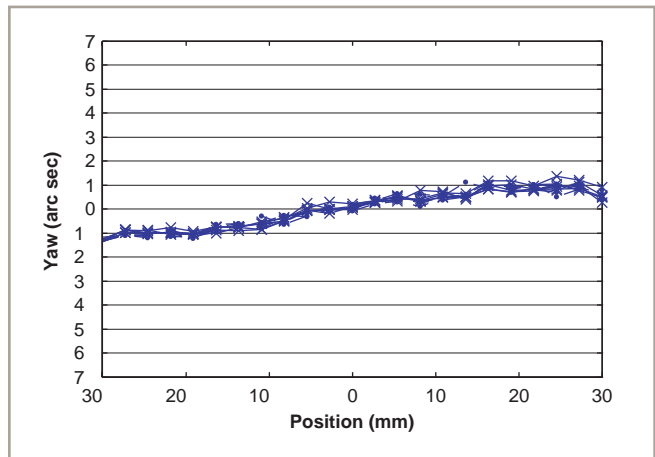

ANTI130-060-XY-ULTRA Y (upper) axis yaw, five runs, bi-directional. Highly repeatable, lowest angular error over full travel.

# ANT130-XY-ULTRA DIMENSIONS

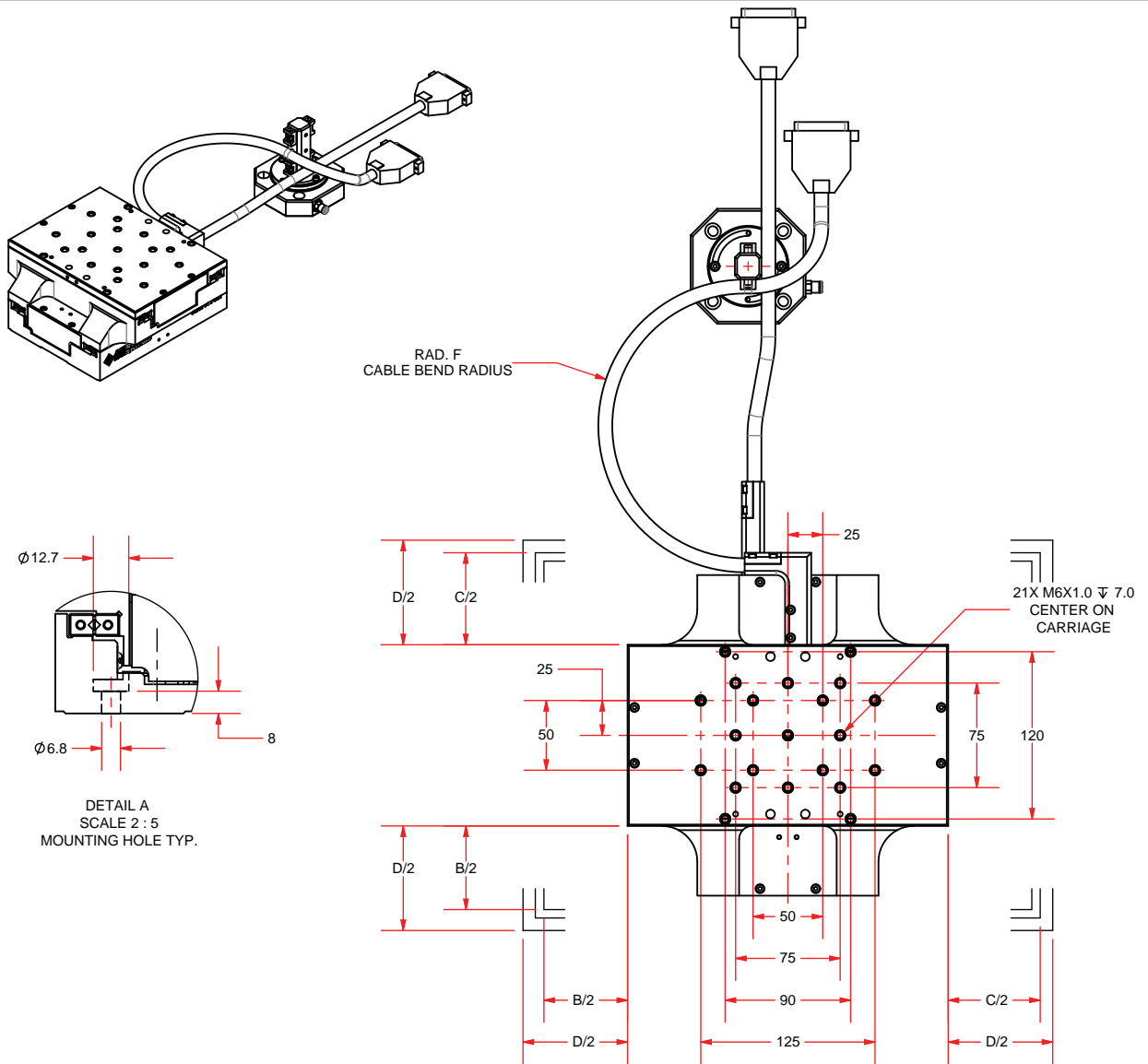

MODEL	A = STAGE LENGTH	B = NOMINAL TRAVEL	C = LIMIT TRAVEL	D = HARDSTOP TRAVEL	E	F
ANT130-060-XY	180	60 X 60	66 X 66	75 X 75	42	-87.5
ANT130-110-XY	230	110 X 110	116 X 116	125 X 125	67	-100
ANT130-160-XY	280	160 X 160	166 X 166	175 X 175	92	-112.5

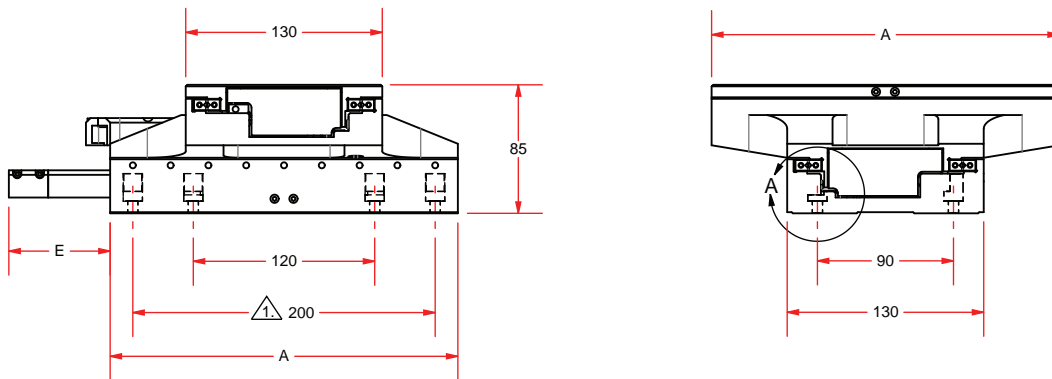

$\triangle$  ANT130-110-XY AND ANT130-160-XY ONLY

DIMENSIONS: MILLIMETERS

# ANT130-XY-ULTRA Mounting Plate DIMENSIONS

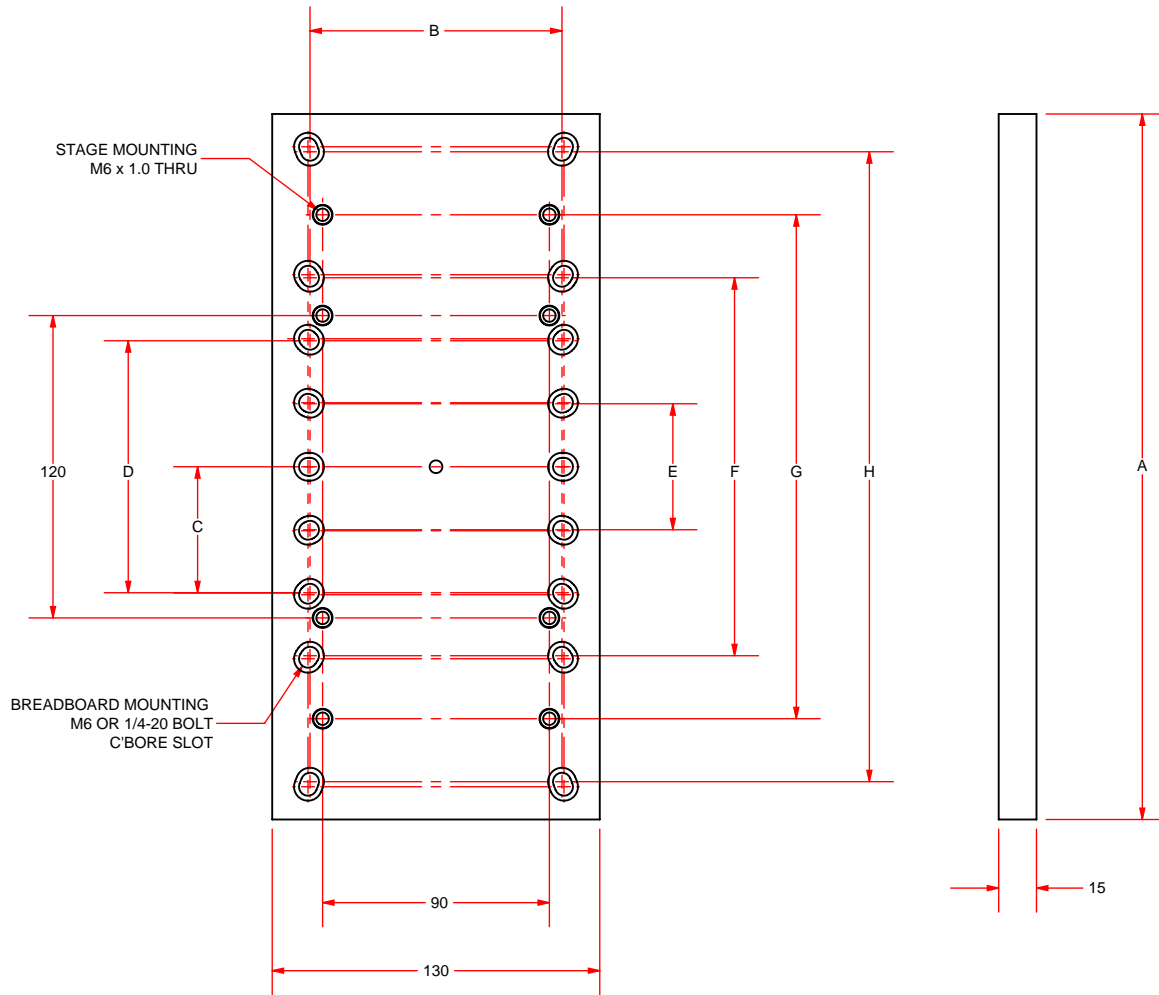

OPTION	LENGTH		MOUNTING					
	A	B	C	D	E	F	G	H
MP-ANT130-035	155	100[4.0]	50[2.0]	100[4.0]	--	--	--	--
MP-ANT130-060	180	100[4.0]	--	--	50[2.0]	150[6.0]	--	--
MP-ANT130-110	230	100[4.0]	--	--	50[2.0]	150[6.0]	200	--
MP-ANT130-160	280	100[4.0]	--	--	50[2.0]	150[6.0]	200	250[10.0]

DIMENSIONS: MILLIMETERS



# ANT130-XY-ULTRA CMS Post DIMENSIONS

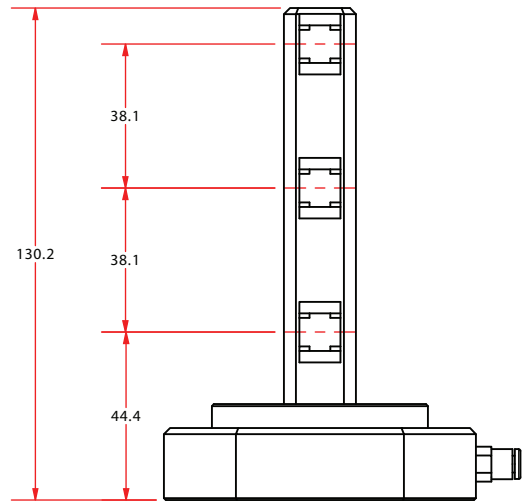
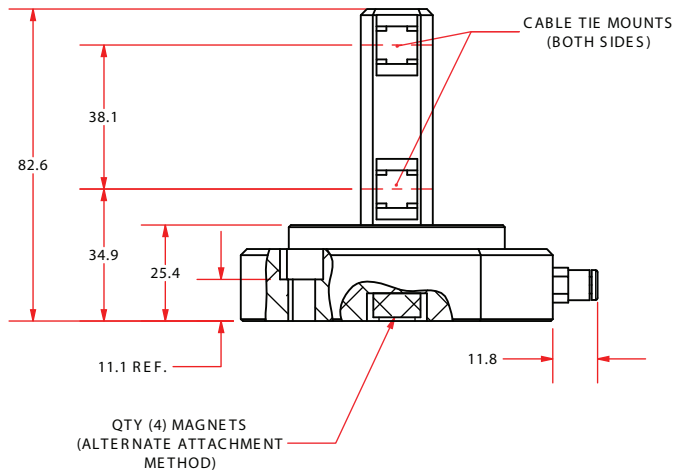
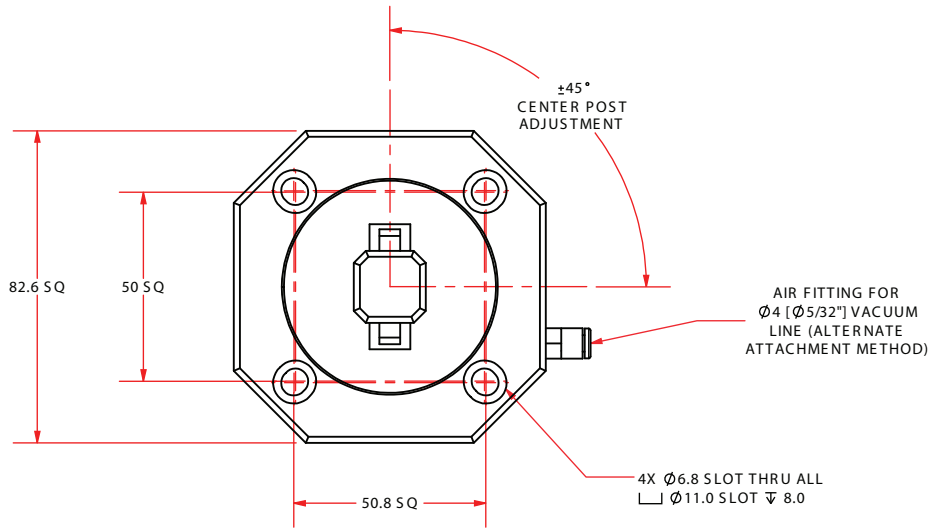

ACP3: INCLUDED WITH  
"-XYZ-CMS" OPTION  
NOTE: DIMENSIONS NOT SHOWN  
ARE THE SAME AS ACP2

ACP2: INCLUDED WITH  
"-XY-CMS" OPTION

DIMENSIONS: MILLIMETERS

## ANT130-XY-ULTRA Series ORDERING INFORMATION

### ANT130-XY-ULTRA Series Linear Stage

ANT130-XY-ULTRA	Aerotech nanotranslation crossed-roller linear positioner with 2D calibration
-----------------	---

#### Linear Stage Travel

ANT130-060-XY-ULTRA	60 mm travel XY stage with linear motor and limits (high accuracy version)
ANT130-110-XY-ULTRA	110 mm travel XY stage with linear motor and limits (high accuracy version)
ANT130-160-XY-ULTRA	160 mm travel XY stage with linear motor and limits (high accuracy version)

#### Output Cable Connectors

-25DU	Single 25-pin D connector (standard)
-4DU-25DU	4-pin HPD and 25-pin D connectors

Note: -25DU single 25-pin connector option not valid for systems using bus voltages greater than 80 V

#### CMS Post

-XY-CMS	Post for two-axis cable anchoring (ACP2 – see product drawing)
-XYZ-CMS	Post for three-axis cable anchoring (ACP3 – see product drawing)

#### Options

-MP	Breadboard mounting plate
-----	---------------------------

# ANT95-R Series

## Single-Axis Rotary Direct-Drive Nanopositioning Stages

- High resolution (0.01 arc sec)
- High performance
- Unlimited rotation
- Outstanding error motion specifications
- Excellent in-position stability
- Multi-axis configurations
- High dynamic performance

nano Motion Technology



### Introduction

The ANT95-R and ANT95-R-PLUS direct-drive rotary stages are designed as part of Aerotech's nano Motion Technology product family. Our rotary stages offer unprecedented in-position stability (0.005 arc sec) and sub 0.01 arc-sec incremental motion performance, and are offered in two grades of accuracy.

### Multi-Axis Capabilities

The ANT95-R series is designed for compatibility and easy integration with Aerotech's ANT linear stage product offerings. Together these stages provide accuracy, stability,

and small-size performance capability for almost any nano-manufacturing or inspection application.

### Dynamic Performance

In addition to the high precision levels, these systems offer high dynamic performance and throughput ideal for disk drive manufacture and test.

### Durability

The ANT95-R stage series was designed to operate in a 24/7 manufacturing environment. Unlike other rotary devices, the ANT95-R requires no periodic maintenance, assuring years of trouble-free operation.

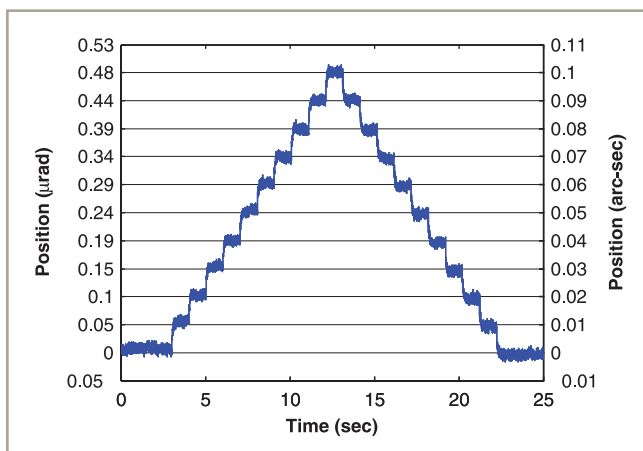

ANT95-R 0.01 arc sec step plot. Best-in-class resolution and exceptional in-position stability for unlimited rotation stages.

## ANT95-R/ANT95-R-PLUS Series SPECIFICATIONS

Mechanical Specifications		ANT95-20-R	ANT95-20-R-PLUS	ANT95-180-R	ANT95-180-R-PLUS	ANT95-360-R	ANT95-360-R-PLUS
Rotation Angle		20°	20°	180°	180°	±360° Continuous	±360° Continuous
Accuracy <sup>(1)</sup>		10 arc sec	3 arc sec	10 arc sec	3 arc sec	10 arc sec	3 arc sec
Resolution		0.01 arc sec	0.01 arc sec	0.01 arc sec	0.01 arc sec	0.01 arc sec	0.01 arc sec
Repeatability (Bi-Directional) <sup>(1)</sup>		1.5 arc sec	1.5 arc sec	1.5 arc sec	1.5 arc sec	1.5 arc sec	1.5 arc sec
Repeatability (Uni-Directional)		0.5 arc sec	0.5 arc sec	0.5 arc sec	0.5 arc sec	0.5 arc sec	0.5 arc sec
Tilt Error Motion	Synchronous	NA	NA	NA	NA	10 arc sec	10 arc sec
	Asynchronous	NA	NA	NA	NA	3 arc sec	3 arc sec
Axial Error Motion <sup>(4)</sup>	Synchronous	NA	NA	NA	NA	2 µm	2 µm
	Asynchronous	NA	NA	NA	NA	0.5 µm	0.5 µm
Radial Error Motion <sup>(4)</sup>	Synchronous	NA	NA	NA	NA	3 µm	3 µm
	Asynchronous	NA	NA	NA	NA	1 µm	1 µm
Maximum Speed		20 rpm	20 rpm	20 rpm	20 rpm	200 rpm	200 rpm
Maximum Acceleration		400 rad/s <sup>2</sup>	400 rad/s <sup>2</sup>	400 rad/s <sup>2</sup>	400 rad/s <sup>2</sup>	400 rad/s <sup>2</sup>	400 rad/s <sup>2</sup>
In-Position Stability <sup>(2)</sup>		0.005 arc sec	0.005 arc sec	0.005 arc sec	0.005 arc sec	0.005 arc sec	0.005 arc sec
Aperture		11 mm (0.433 in)	11 mm (0.433 in)	11 mm (0.433 in)	11 mm (0.433 in)	11 mm (0.433 in)	11 mm (0.433 in)
Maximum Torque (Continuous)		0.2 Nm	0.2 Nm	0.2 Nm	0.2 Nm	0.2 Nm	0.2 Nm
Load Capacity <sup>(5)</sup>	Axial	2.0 kg (4.4 lb)	2.0 kg (4.4 lb)	2.0 kg (4.4 lb)	2.0 kg (4.4 lb)	2.0 kg (4.4 lb)	2.0 kg (4.4 lb)
	Radial	1.5 kg (3.3 lb)	1.5 kg (3.3 lb)	1.5 kg (3.3 lb)	1.5 kg (3.3 lb)	1.5 kg (3.3 lb)	1.5 kg (3.3 lb)
	Moment	2 Nm	2 Nm	2 Nm	2 Nm	2 Nm	2 Nm
Rotor Inertia (Unloaded)		0.00065 kg-m <sup>2</sup>	0.00065 kg-m <sup>2</sup>	0.00066 kg-m <sup>2</sup>	0.00066 kg-m <sup>2</sup>	0.00069 kg-m <sup>2</sup>	0.00069 kg-m <sup>2</sup>
Stage Mass		1.2 kg (2.6 lb)	1.2 kg (2.6 lb)	1.2 kg (2.6 lb)	1.2 kg (2.6 lb)	1.2 kg (2.6 lb)	1.2 kg (2.6 lb)
Material		Aluminum Body/Black Hardcoat Finish					
MTBF (Mean Time Between Failure)		30,000 Hours					

Notes:

1. Certified with each stage. Requires the use of an Aerotech controller.
2. In-Position Jitter listing is 3 sigma value.
3. Axis orientation for on-axis loading is listed.
- Specifications are per axis, measured 25 mm above the tabletop. Consult factory for multi-axis or non-standard applications.
- All error motion specifications are measured at 60 rpm.
- For high speed operation, customer payload must be balanced to G1.0 per ISO 1940.

Electrical Specifications	ANT95-20-R ANT95-20-R-PLUS	ANT95-180-R ANT95-180-R-PLUS	ANT95-360-R ANT95-360-R-PLUS
Drive System	Slotless, Brushless, Direct-Drive Rotary Motor		
Feedback	Noncontact Rotary Encoder		
Maximum Bus Voltage	±40 VDC		
Limit Switches	5 V, Normally Closed		
Home Switch	Near Center		

Recommended Controller	ANT95-20-R ANT95-20-R-PLUS	ANT95-180-R ANT95-180-R-PLUS	ANT95-360-R ANT95-360-R-PLUS
Multi-Axis	A3200	Npaq MXR Npaq MR-MXH Ndrive ML-MXH	
	Ensemble	Epaq MXR Epaq MR-MXH Ensemble ML-MXH	
Single Axis	Soloist	Soloist ML-MXH	

Notes:

1. Linear amplifiers are required to achieve the listed specifications. Other options are available.

Note: To ensure the achievement and repeatability of specifications over an extended period of time, environmental temperature must be controlled to within 0.25°C/24 hours. If this is not possible, alternate products are available. Please consult Aerotech Application Engineering for more information.

# ANT95-R/ANT95-R-PLUS Series PERFORMANCE

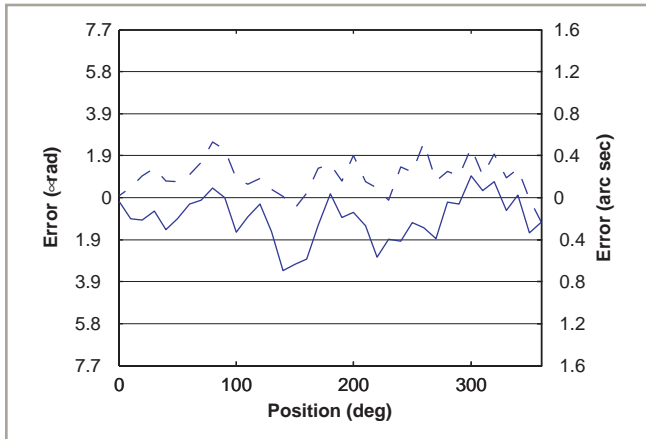

ANT95-R-PLUS accuracy plot showing excellent accuracy and bi-directional positioning capability.

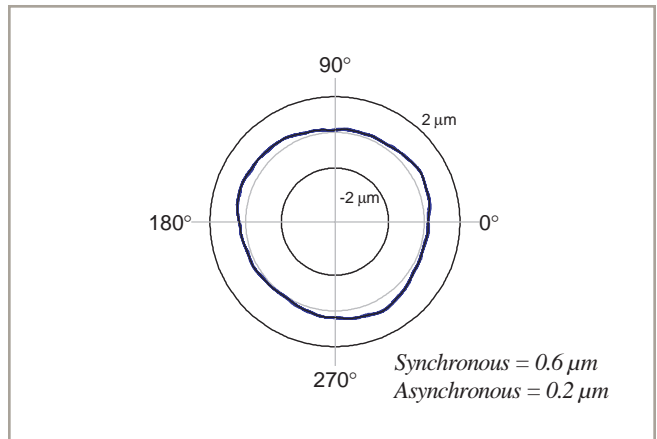

ANT95-R axial error plot illustrating outstanding synchronous and asynchronous error motion performance.

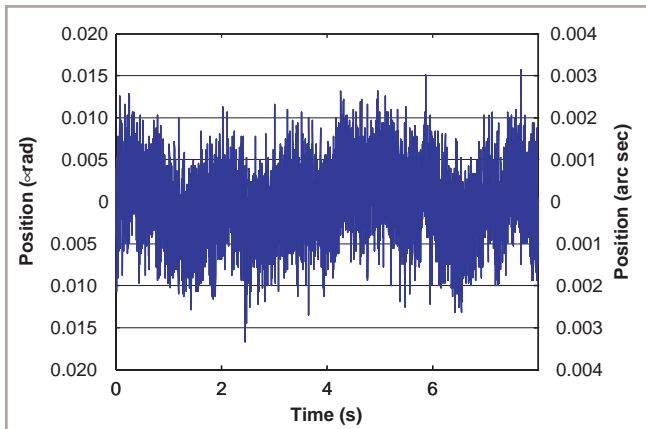

ANT95-R plot showing best-in-class in-position stability.

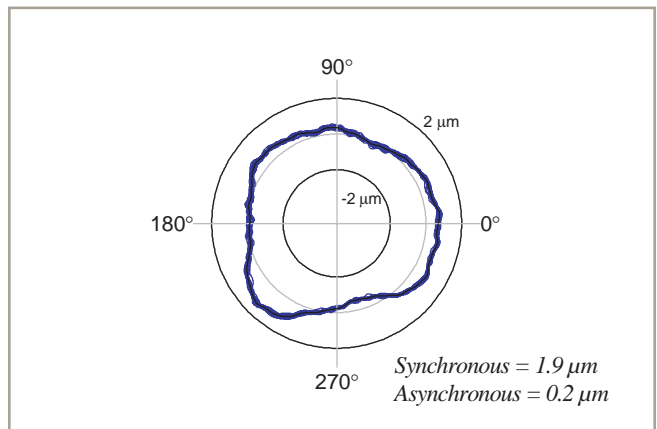

ANT95-R radial error plot illustrating outstanding synchronous and asynchronous error motion performance.

# ANT95-R/ANT95-R-PLUS DIMENSIONS

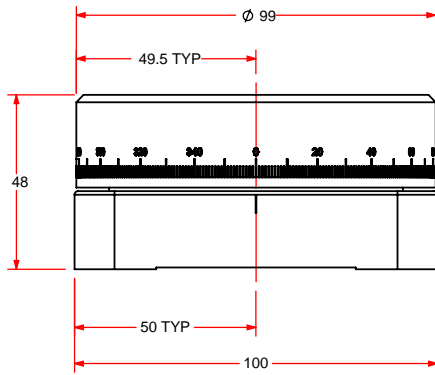
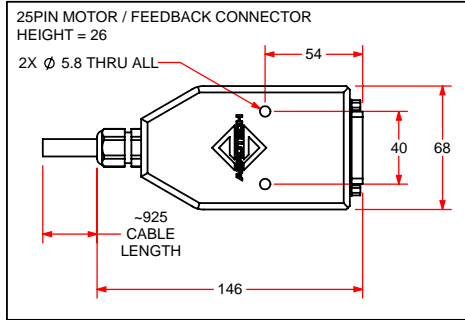
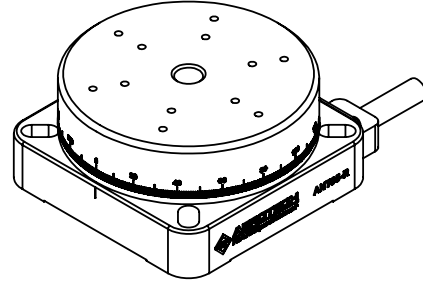
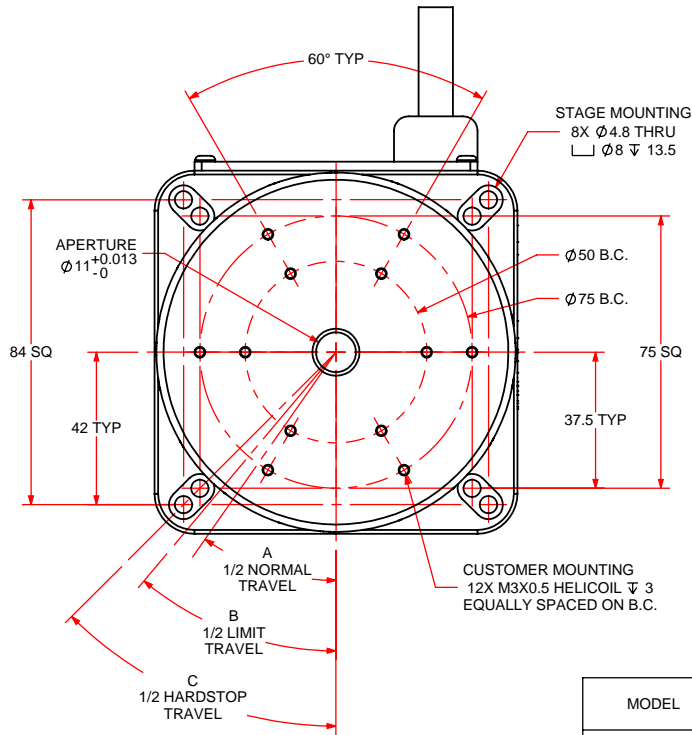

MODEL	TRAVEL (DEGREES)		
	A	B	C
ANT95-20-R	10	15	27
ANT95-180-R	90	95	107
ANT95-360-R	360 CONT.	-	-

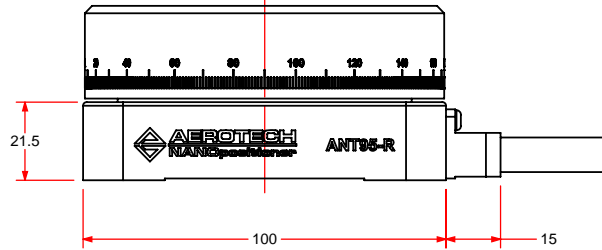

## ANT95-R/ANT95-R-PLUS Mounting Plate DIMENSIONS

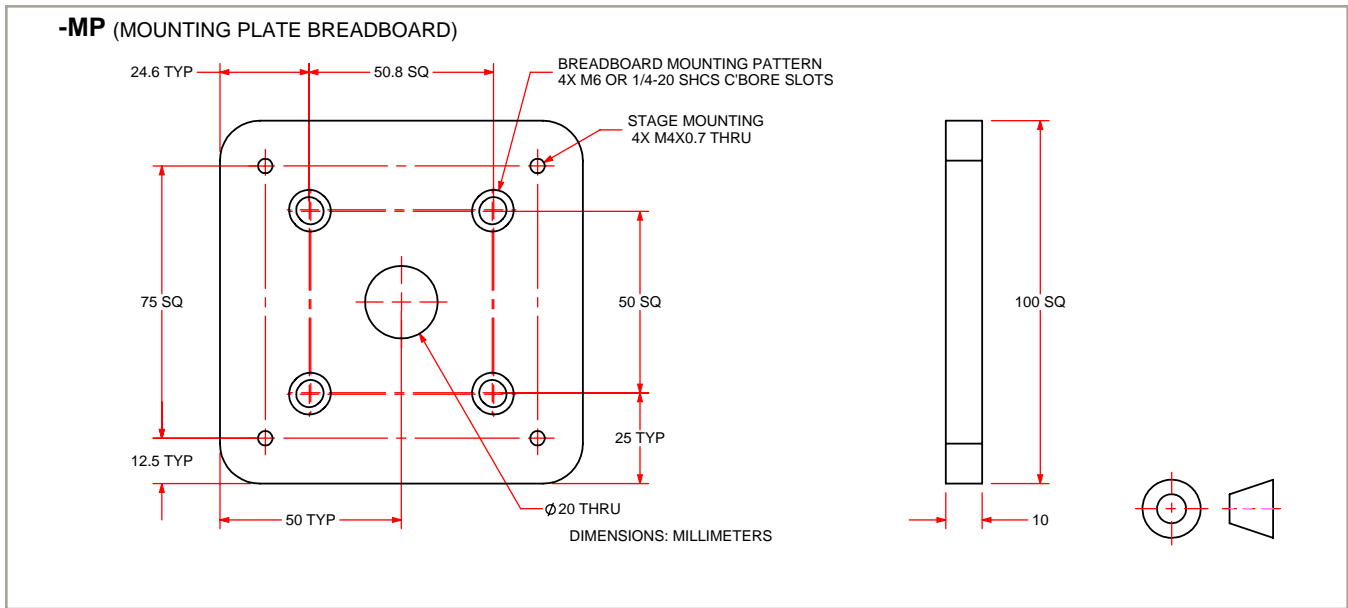

## ANT95-R/ANT95-R-PLUS Series ORDERING INFORMATION

### ANT95-R Series Rotary Stage

ANT95-R Aerotech direct-drive rotary positioner

### Rotary Stage Travel

ANT95-20-R	20° rotation stage with slotless, brushless, direct-drive motor, direct-coupled high-accuracy rotary encoder, optical limits, and hard stops
ANT95-20-R-PLUS	20° rotation stage with slotless, brushless, direct-drive motor, direct-coupled high-accuracy rotary encoder, optical limits, and hard stops (high accuracy version)
ANT95-180-R	180° rotation stage with slotless, brushless, direct-drive motor, direct-coupled high-accuracy rotary encoder, optical limits, and hard stops
ANT95-180-R-PLUS	180° rotation stage with slotless, brushless, direct-drive motor, direct-coupled high-accuracy rotary encoder, optical limits, and hard stops (high accuracy version)
ANT95-360-R	360° continuous rotation stage with slotless, brushless, direct-drive motor, direct-coupled high-accuracy rotary encoder, and optical limits
ANT95-360-R-PLUS	360° continuous rotation stage with slotless, brushless, direct-drive motor, direct-coupled high-accuracy rotary encoder, and optical limits (high accuracy version)

### Options

-MP Breadboard mounting plate

# ANT130-R Series

## Single-Axis Rotary Direct-Drive Nanopositioning Stages

- High resolution (0.01 arc sec)
- High performance
- Unlimited rotation
- Outstanding error motion specifications
- Excellent in-position stability
- Multi-axis configurations
- High dynamic performance

nano Motion Technology

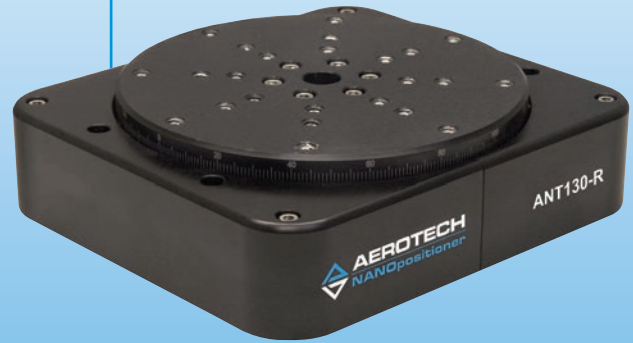

The ANT130-R and ANT130-R-PLUS direct-drive rotary stages are designed as part of Aerotech's nano Motion Technology product family. Our rotary stages offer unprecedented in-position stability (0.005 arc sec) and sub 0.01 arc-sec incremental motion performance, and are offered in two grades of accuracy.

### Multi-Axis Capabilities

The ANT130-R series is designed for compatibility and easy integration with Aerotech's ANT linear stage product offerings. Together these stages provide accuracy, stability, and small-size performance capability for almost any nano-manufacturing or inspection application.

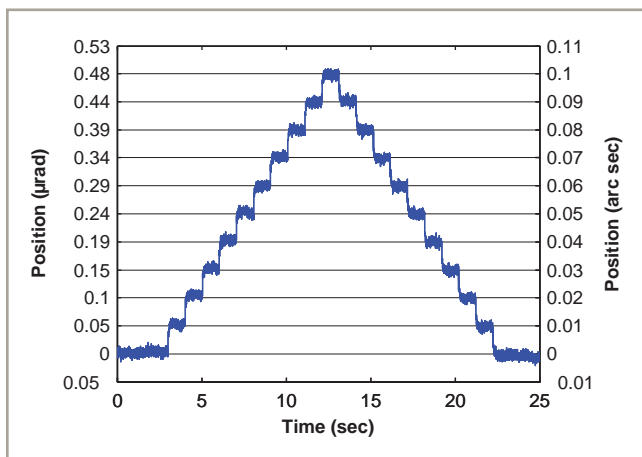

*ANT130-R 0.01 arc sec step plot. Best-in-class resolution and exceptional in-position stability for unlimited rotation stages. See additional performance graphs on the following pages.*

### Dynamic Performance

In addition to the high precision levels, these systems offer high dynamic performance and throughput ideal for disk drive manufacture and test.

### Durability

The ANT130-R stage series was designed to operate in a 24/7 manufacturing environment. Unlike other rotary devices, the ANT130-R requires no periodic maintenance, assuring years of trouble-free operation.



# ANT130-R/ANT130-R-PLUS Series SPECIFICATIONS

Mechanical Specifications		ANT130-20-R	ANT130-20-R-PLUS	ANT130-180-R	ANT130-180-R-PLUS	ANT130-360-R	ANT130-360-R-PLUS
Rotation Angle		20°	20°	180°	180°	±360° Continuous	±360° Continuous
Accuracy <sup>(1)</sup>		10 arc sec	3 arc sec	10 arc sec	3 arc sec	10 arc sec	3 arc sec
Resolution		0.01 arc sec	0.01 arc sec	0.01 arc sec	0.01 arc sec	0.01 arc sec	0.01 arc sec
Repeatability (Bi-Directional) <sup>(1)</sup>		1.5 arc sec	1.5 arc sec	1.5 arc sec	1.5 arc sec	1.5 arc sec	1.5 arc sec
Repeatability (Uni-Directional)		0.5 arc sec	0.5 arc sec	0.5 arc sec	0.5 arc sec	0.5 arc sec	0.5 arc sec
Tilt Error Motion	Synchronous	NA	NA	NA	NA	10 arc sec	10 arc sec
	Asynchronous	NA	NA	NA	NA	3 arc sec	3 arc sec
Axial Error Motion <sup>(1)</sup>	Synchronous	NA	NA	NA	NA	2 µm	2 µm
	Asynchronous	NA	NA	NA	NA	0.5 µm	0.5 µm
Radial Error Motion <sup>(1)</sup>	Synchronous	NA	NA	NA	NA	3 µm	3 µm
	Asynchronous	NA	NA	NA	NA	1 µm	1 µm
Maximum Speed		20 rpm	20 rpm	20 rpm	20 rpm	200 rpm	200 rpm
Maximum Acceleration		400 rad/s <sup>2</sup>	400 rad/s <sup>2</sup>	400 rad/s <sup>2</sup>	400 rad/s <sup>2</sup>	400 rad/s <sup>2</sup>	400 rad/s <sup>2</sup>
In-Position Stability <sup>(2)</sup>		0.005 arc sec	0.005 arc sec	0.005 arc sec	0.005 arc sec	0.005 arc sec	0.005 arc sec
Aperture		11 mm	11 mm	11 mm	11 mm	11 mm	11 mm
Maximum Torque (Continuous)		0.2 Nm	0.2 Nm	0.2 Nm	0.2 Nm	0.2 Nm	0.2 Nm
Load Capacity <sup>(3)</sup>	Axial	3.0 kg (6.6 lb)	3.0 kg (6.6 lb)	3.0 kg (6.6 lb)	3.0 kg (6.6 lb)	3.0 kg (6.6 lb)	3.0 kg (6.6 lb)
	Radial	2.0 kg (4.4 lb)	2.0 kg (4.4 lb)	2.0 kg (4.4 lb)	2.0 kg (4.4 lb)	2.0 kg (4.4 lb)	2.0 kg (4.4 lb)
	Moment	3 Nm	3 Nm	3 Nm	3 Nm	3 Nm	3 Nm
Rotor Inertia (Unloaded)		0.001 kg-m <sup>2</sup>	0.001 kg-m <sup>2</sup>	0.001 kg-m <sup>2</sup>	0.001 kg-m <sup>2</sup>	0.0016 kg-m <sup>2</sup>	0.0016 kg-m <sup>2</sup>
Stage Mass		1.5 kg (3.3 lb)	1.5 kg (3.3 lb)	1.5 kg (3.3 lb)	1.5 kg (3.3 lb)	1.7 kg (3.74 lb)	1.7 kg (3.74 lb)
Material		Aluminum Body/Black Hardcoat Finish					
MTBF (Mean Time Between Failure)		30,000 Hours					

- Notes:
1. Certified with each stage. Requires the use of an Aerotech controller.
  2. In-Position Jitter listing is 3 sigma value.
  3. Axis orientation for on-axis loading is listed.
- Specifications are per axis, measured 25 mm above the tabletop. Consult factory for multi-axis or non-standard applications.
  - All error motion specifications are measured at 60 rpm.
  - For high speed operation, customer payload must be balanced to G1.0 per ISO 1940.

Electrical Specifications	ANT130-20-R ANT130-20-R-PLUS	ANT130-180-R ANT130-180-R-PLUS	ANT130-360-R ANT130-360-R-PLUS
Drive System	Slotless, Brushless, Direct-Drive Rotary Motor		
Feedback	Noncontact Rotary Encoder		
Maximum Bus Voltage	±40 VDC		
Limit Switches	5 V, Normally Closed		
Home Switch	Near Center		

Recommended Controller	ANT130-20-R ANT130-20-R-PLUS	ANT130-180-R ANT130-180-R-PLUS	ANT130-360-R ANT130-360-R-PLUS
Multi-Axis	A3200	Npaq MXR Npaq MR-MXH Ndrive ML-MXH	
	Ensemble	Epaq MXR Epaq MR-MXH Ensemble ML-MXH	
Single Axis	Soloist	Soloist ML-MXH	

- Notes:
1. Linear amplifiers are required to achieve the listed specifications. Other options are available.

Note: To ensure the achievement and repeatability of specifications over an extended period of time, environmental temperature must be controlled to within 0.25°C/24 hours. If this is not possible, alternate products are available. Please consult Aerotech Application Engineering for more information.

ANT130-R/ANT130-R-PLUS Series PERFORMANCE

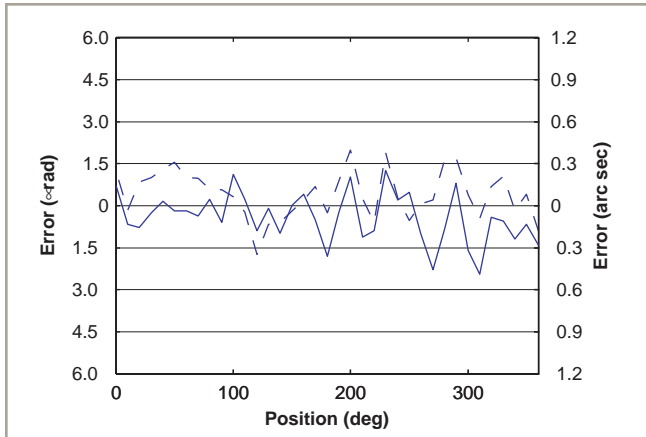

ANT130-R-PLUS accuracy plots showing excellent accuracy and bi-directional positioning capability.

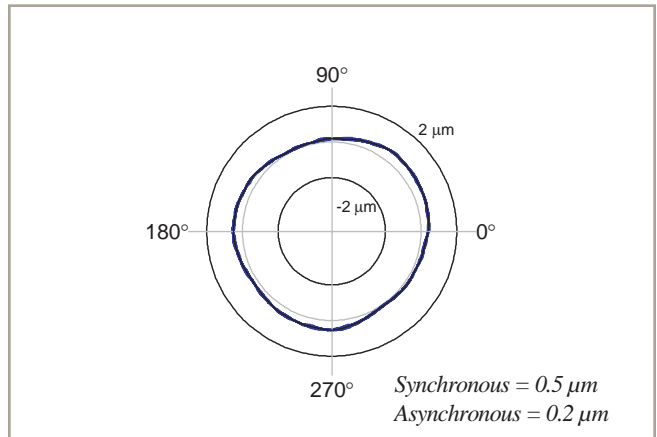

ANT130-R axial error plot illustrating outstanding synchronous and asynchronous error motion performance.

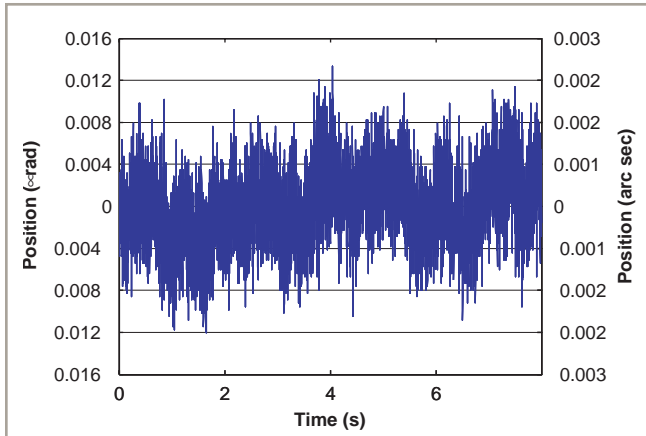

ANT130-R plot showing best-in-class in-position stability.

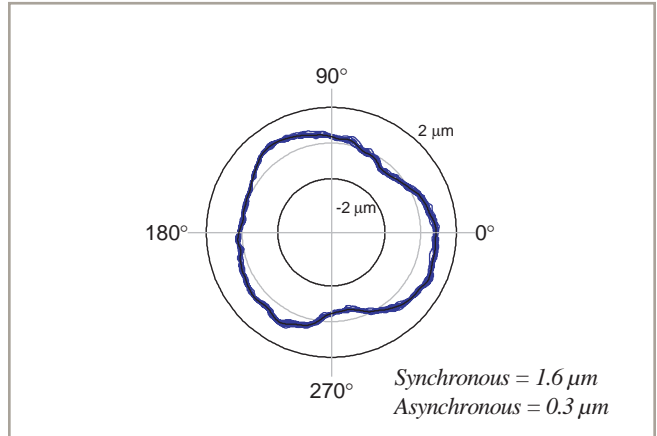

ANT130-R radial error plot illustrating outstanding synchronous and asynchronous error motion performance.

# ANT130-R/ANT130-R-PLUS DIMENSIONS

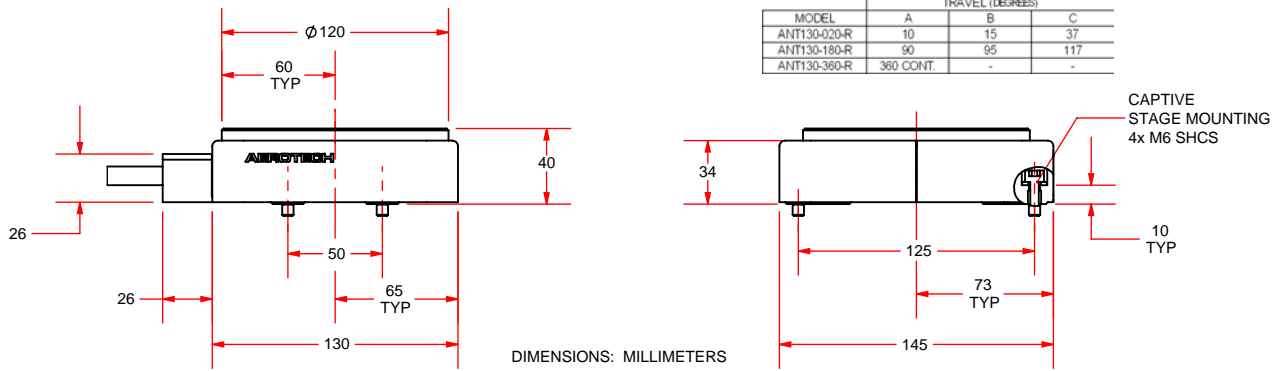
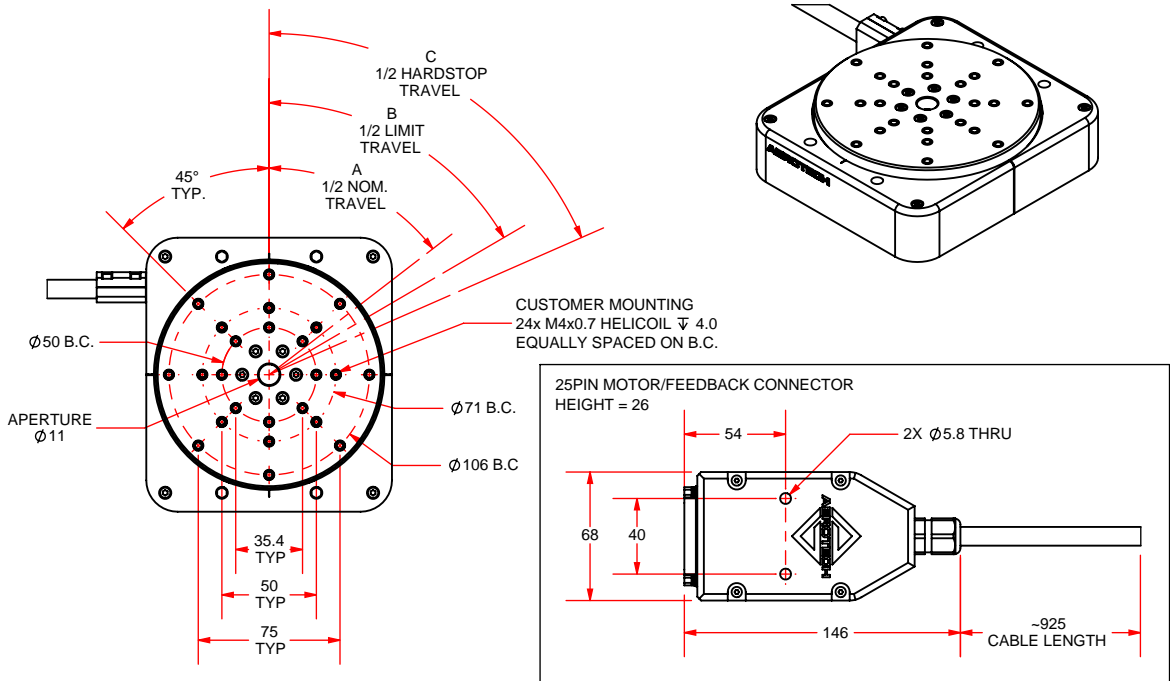

## ANT130-R/ANT130-R-PLUS Mounting Plate DIMENSIONS

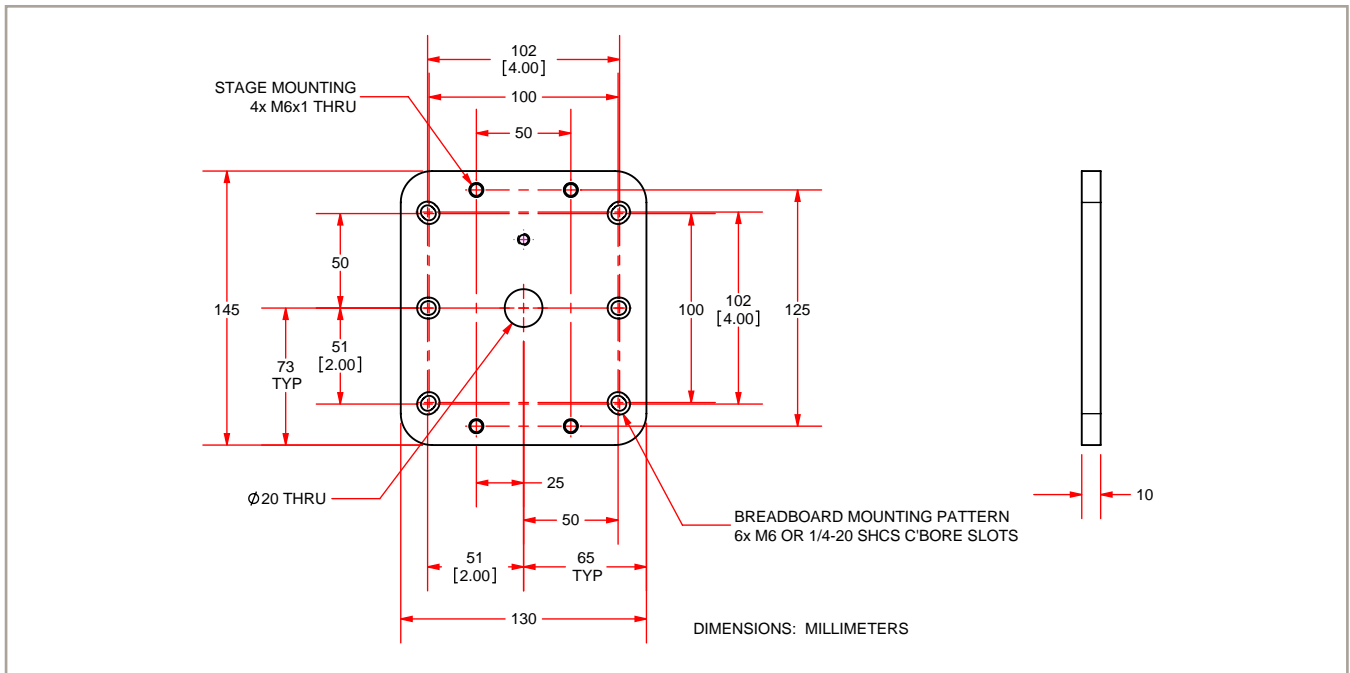

## ANT130-R/ANT130-R-PLUS Series ORDERING INFORMATION

### ANT130-R Series Rotary Stage

ANT130-R Aerotech direct-drive rotary positioner

### Rotary Stage Travel

ANT130-20-R	20° rotation stage with slotless, brushless, direct-drive motor, direct-coupled high-accuracy rotary encoder, optical limits, and hard stops
ANT130-20-R-PLUS	20° rotation stage with slotless, brushless, direct-drive motor, direct-coupled high-accuracy rotary encoder, optical limits, and hard stops (high accuracy version)
ANT130-180-R	180° rotation stage with slotless, brushless, direct-drive motor, direct-coupled high-accuracy rotary encoder, optical limits, and hard stops
ANT130-180-R-PLUS	180° rotation stage with slotless, brushless, direct-drive motor, direct-coupled high-accuracy rotary encoder, optical limits, and hard stops (high accuracy version)
ANT130-360-R	360° continuous rotation stage with slotless, brushless, direct-drive motor, direct-coupled high-accuracy rotary encoder, and optical limits
ANT130-360-R-PLUS	360° continuous rotation stage with slotless, brushless, direct-drive motor, direct-coupled high-accuracy rotary encoder, and optical limits (high accuracy version)

### Options

-MP Breadboard mounting plate

# ANT95-L-Z Series

## Single-Axis Z Direct-Drive Nanopositioning Stages

Nanometer performance in a large travel format (25 and 50 mm)

High resolution (2 nm), repeatability (75 nm), and accuracy (300 nm)

In-position stability of <2 nm

Anti-creep crossed-roller bearings

High dynamic performance

nano Motion Technology

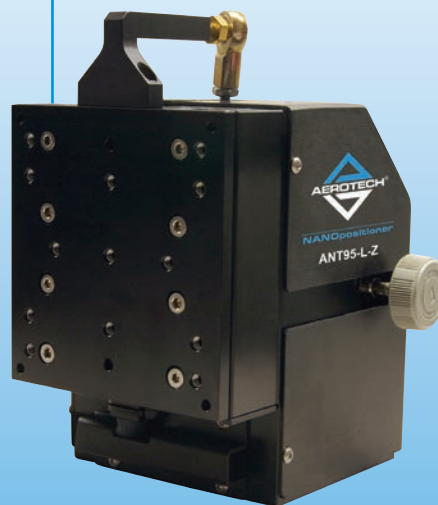

### Introduction

Aerotech's ANT series stages are the world's first nanometer-level positioning systems with greater than 25 mm travel. The ANT95-L-Z and ANT95-L-Z-PLUS crossed-roller stages are the best-in-class in combining speed, accuracy, resolution, repeatability, reliability, and size, and are offered in two accuracy grades. As an evolution of the ANT stage family, these linear stages exhibit enhanced motion performance over Aerotech's first generation ANT series.

### Noncontact Direct-Drive

All of the original ANT series' direct-drive advantages have been preserved in the ANT95-L-Z family. Only noncontact direct-drive technology offers the robust, accurate, and high-speed positioning necessary for mass production of precision devices. ANT95-L-Z stages utilize advanced direct-drive technology pioneered by Aerotech to achieve the highest level of positioning performance for high-precision positioning, disk-drive fabrication, fiber alignment, optical delay element actuation, sensor testing, and scanning processes that demand smooth and precise motion.

The ANT95-L-Z stages use a nearly frictionless counterbalance mechanism to maintain performance levels while minimizing motor heating. The counterbalance is user-adjustable from 0 to 5 kg.

### Flexible System Design

The ANT95-L-Z family has universal mounting and tabletop patterns that allow for easy system integration. Two, three, or

more axes can be easily combined for flexible system designs and multi-axis configurations.

### System Characteristics

Outstanding accuracy, position repeatability, and in-position stability require high system resolution. The ANT95-L-Z stage's industry-leading 2 nm minimum incremental step size provides this high level of performance. Excellent in-position stability is assisted by high-quality, anti-creep, crossed-roller bearings. The stage offers virtually maintenance-free operation over the life of the product. Aerotech's direct-drive technology has no hysteresis or backlash, enabling accurate and repeatable nanometer-scale motion.

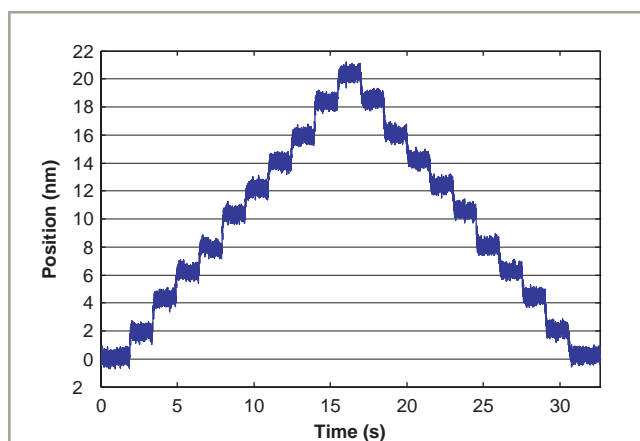

*ANT95-50-L-Z-PLUS 2 nm step plot with 100 Hz filter. Best-in-class resolution and exceptional in-position stability for large travel stages.*

## ANT95-L-Z/ANT95-L-Z-PLUS Series SPECIFICATIONS

Mechanical Specifications	ANT95-25-L-Z	ANT95-25-L-Z-PLUS	ANT95-50-L-Z	ANT95-50-L-Z-PLUS
Travel	25 mm	25 mm	50 mm	50 mm
Accuracy <sup>(1)</sup>	±4.0 µm (±160 µin)	±300 nm (±12 µin)	±4.0 µm (±160 µin)	±300 nm (±12 µin)
Resolution	2 nm (0.08 µin)	2 nm (0.08 µin)	2 nm (0.08 µin)	2 nm (0.08 µin)
Repeatability (Bi-Directional) <sup>(1)</sup>	±100 nm (±4 µin)	±75 nm (±3 µin)	±100 nm (±4 µin)	±75 nm (±3 µin)
Repeatability (Uni-Directional)	±50 nm (±2 µin)	±50 nm (±2 µin)	±50 nm (±2 µin)	±50 nm (±2 µin)
Straightness <sup>(1)</sup>	±2.25 µm (±90 µin)	±2.25 µm (±90 µin)	±3.0 µm (±120 µin)	±3.0 µm (±120 µin)
Flatness <sup>(1)</sup>	±3.5 µm (±140 µin)	±3.5 µm (±140 µin)	±4.0 µm (±160 µin)	±4.0 µm (±160 µin)
Pitch	10 arc sec	10 arc sec	10 arc sec	10 arc sec
Roll	10 arc sec	10 arc sec	10 arc sec	10 arc sec
Yaw	5 arc sec	5 arc sec	5 arc sec	5 arc sec
Maximum Speed	200 mm/s (8 in/s)	200 mm/s (8 in/s)	200 mm/s (8 in/s)	200 mm/s (8 in/s)
Maximum Acceleration	1 g - 10 m/s <sup>2</sup> (No Load)	1 g - 10 m/s <sup>2</sup> (No Load)	1 g - 10 m/s <sup>2</sup> (No Load)	1 g - 10 m/s <sup>2</sup> (No Load)
In-Position Stability <sup>(2)</sup>	<2 nm (<0.08 µin)	<2 nm (<0.08 µin)	<2 nm (<0.08 µin)	<2 nm (<0.08 µin)
Maximum Force (Continuous)	7.75 N	7.75 N	9.5 N	9.5 N
Load Capacity <sup>(3)</sup>	Vertical	5.0 kg (11 lb)	5.0 kg (11 lb)	5.0 kg (11 lb)
Moving Mass	0.46 kg (1.0 lb)	0.46 kg (1.0 lb)	0.52 kg (1.1 lb)	0.52 kg (1.1 lb)
Stage Mass	1.9 kg (4.3 lb)	1.9 kg (4.3 lb)	2.5 kg (5.5 lb)	2.5 kg (5.5 lb)
Material	Aluminum Body/Black Hardcoat Finish			
MTBF (Mean Time Between Failure)	30,000 Hours			

Notes:

- Certified with each stage.
  - In-Position Jitter listing is 3 sigma value.
  - Axis orientation for on-axis loading is listed.
  - Air supply must be clean, dry to 0Å°F dew point and filtered to 0.25 1¼m or better; recommend nitrogen at 99.9% purity. Supply pressure is determined by the amount of payload carried by the stage.
- Specifications are per axis, measured 25 mm above the tabletop. Performance of multi-axis systems is payload and workpoint dependent. Consult factory for multi-axis or non-standard applications.
  - PLUS requires the use of an Aerotech controller.

Electrical Specifications	ANT95-25-L-Z	ANT95-25-L-Z-PLUS	ANT95-50-L-Z	ANT95-50-L-Z-PLUS
Drive System	Brushless Linear Servomotor			
Feedback	Noncontact Linear Encoder			
Maximum Bus Voltage	±40 VDC			
Limit Switches	5 V, Normally Closed			
Home Switch	Near Center			

Recommended Controller	ANT95-25-L-Z	ANT95-25-L-Z-PLUS	ANT95-50-L-Z	ANT95-50-L-Z-PLUS
Multi-Axis	A3200	Npaq-MXR Npaq MR-MXH Ndrive ML-MXH		
	Ensemble	Epaq-MXH Epaq MR-MXH Ensemble ML-MXH		
Single Axis	Soloist	Soloist ML-MXH		

Notes:

- Linear amplifiers are required to achieve the listed specifications. Other options are available.

Note: To ensure the achievement and repeatability of specifications over an extended period of time, environmental temperature must be controlled to within 0.25°C/24 hours. If this is not possible, alternate products are available. Please consult Aerotech Application Engineering for more information.

# ANT95-L-Z/ANT95-L-Z-PLUS Series PERFORMANCE

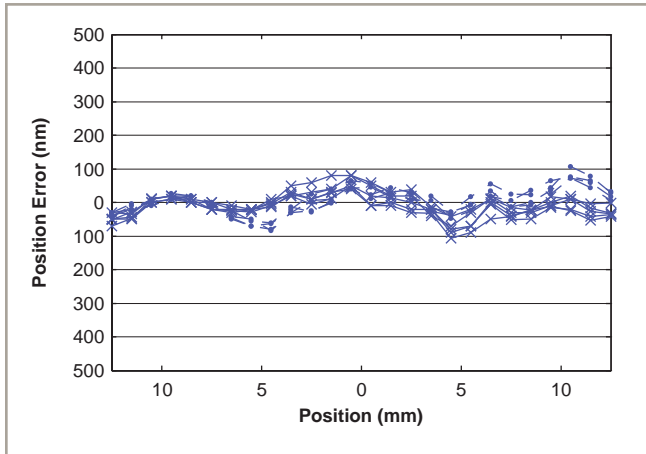

ANT95-25-L-Z-PLUS accuracy and repeatability. This multiple test run over an extended period of time shows the high level of system accuracy and repeatability.

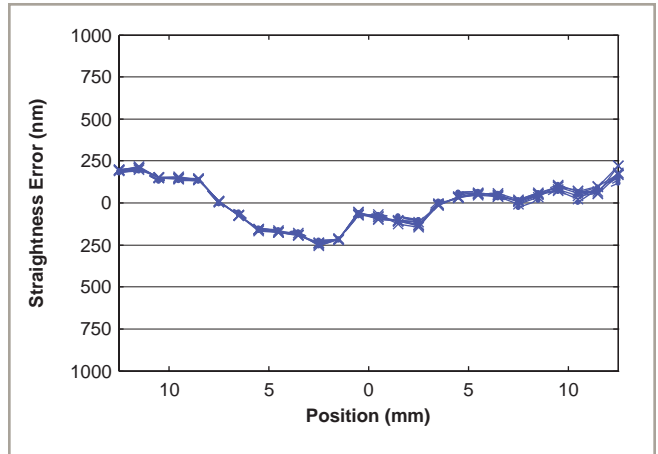

ANT95-25-L-Z-PLUS straightness error, five runs, bi-directional. Exceptional and highly repeatable – five times more accurate than the stated specification.

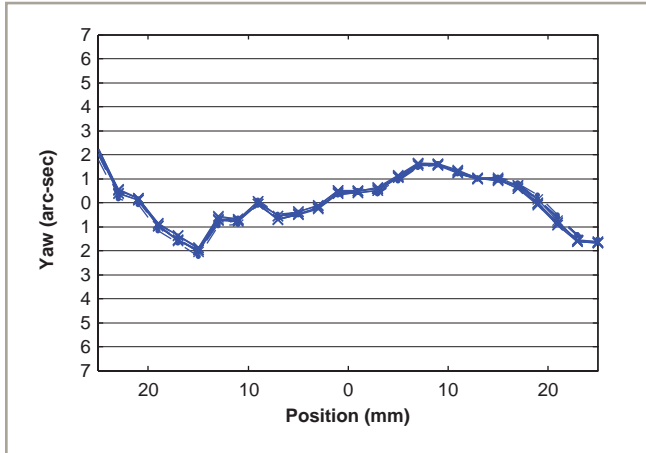

ANT95-50-L-Z-PLUS yaw, five runs, bi-directional. Highly repeatable, minimal yaw error enhances system positioning accuracy.

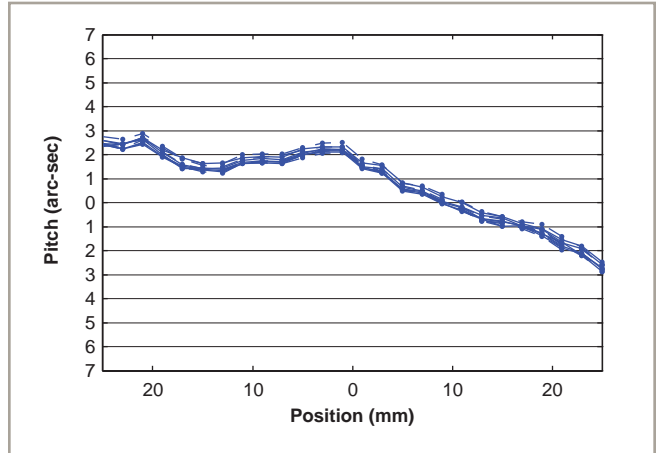

ANT95-50-L-Z-PLUS pitch, five runs, bi-directional. Excellent repeatability/accuracy contribute to improved processing.

ANT95-25-L-Z/ANT95-L-Z-PLUS DIMENSIONS

ANT95-25-L-Z/ANT95-25-L-Z-PLUS

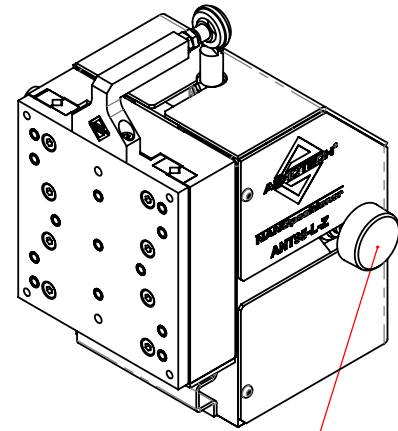
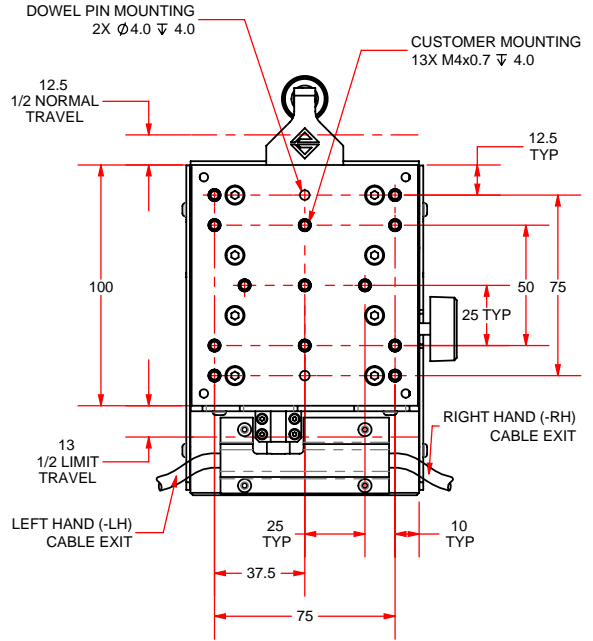
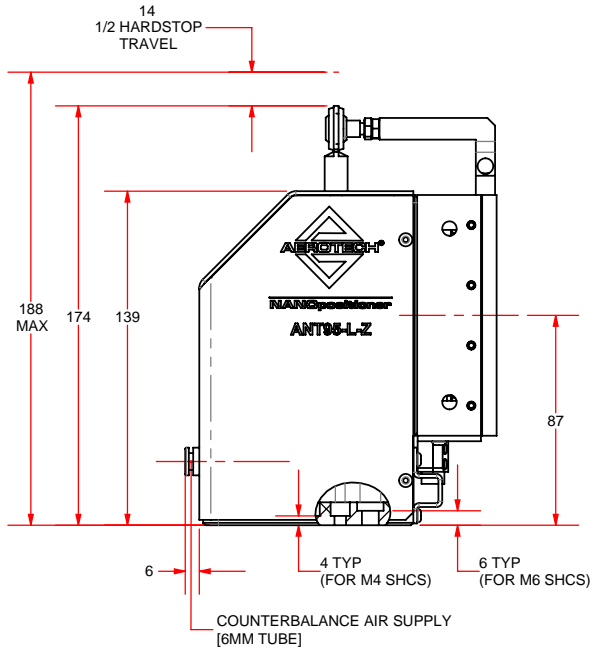

REGULATOR KNOB FOR COUNTERBALANCE ADJUSTMENT

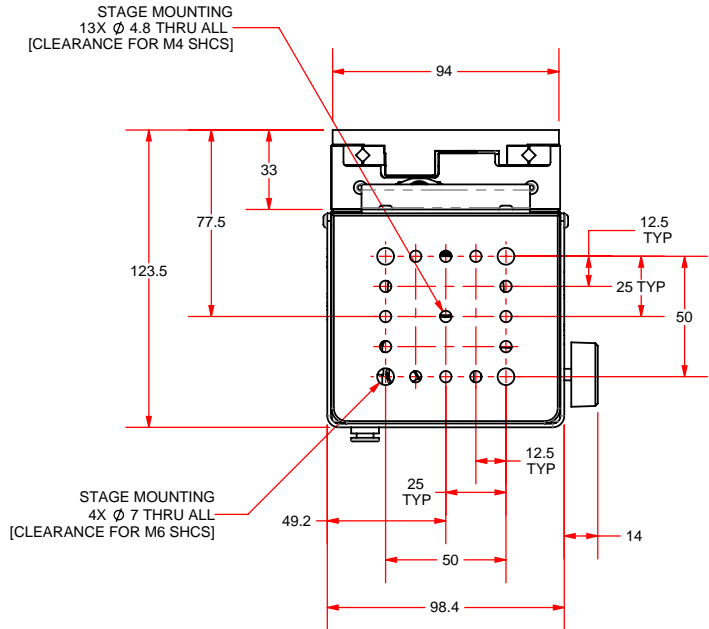



# ANT95-50-L-Z/ANT95-50-L-Z-PLUS DIMENSIONS

## ANT95-50-L-Z/ANT95-50-L-Z-PLUS

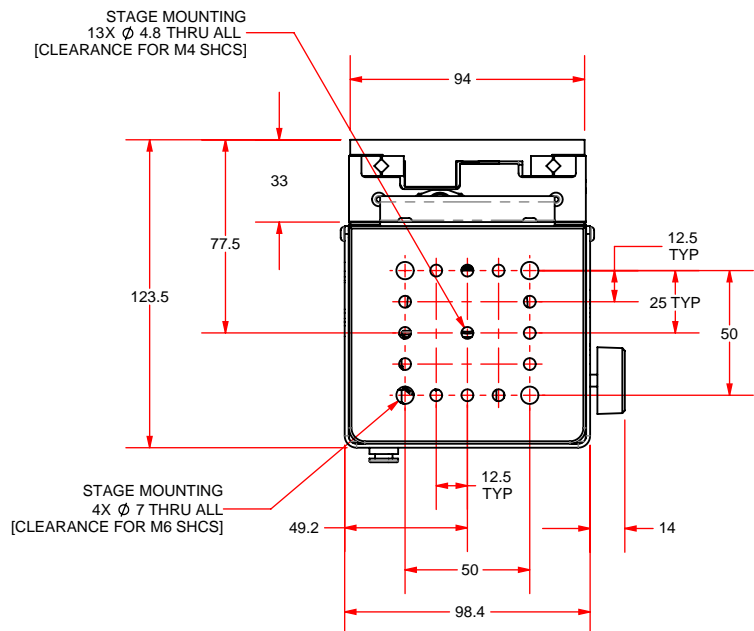
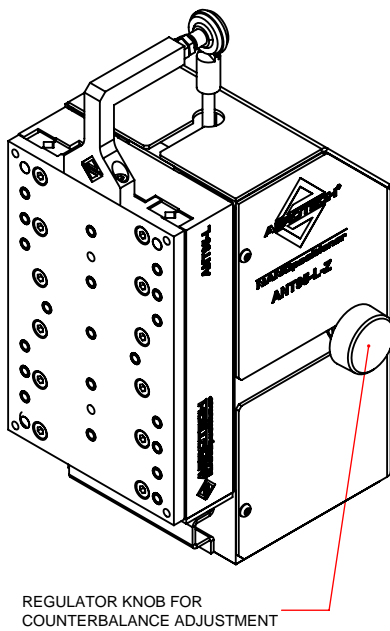
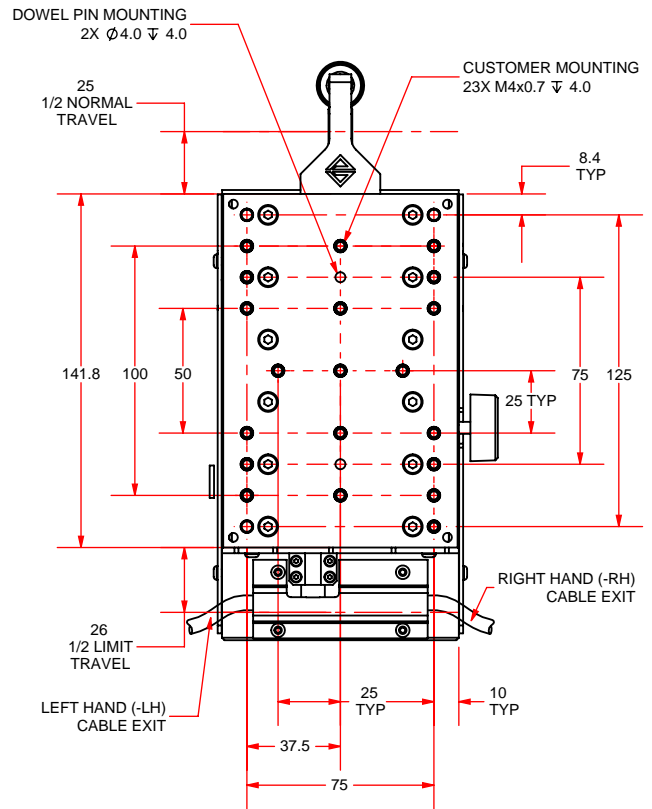
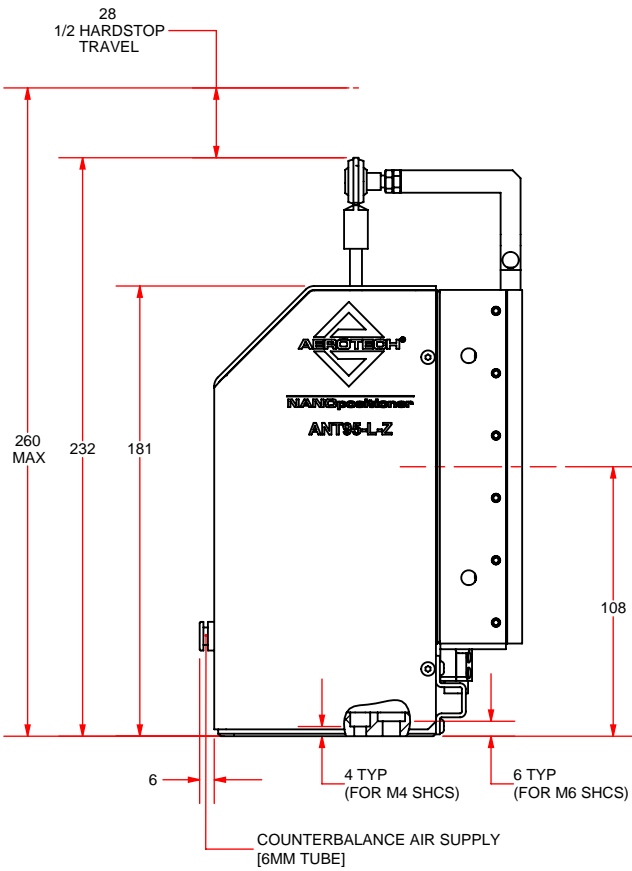

DIMENSIONS: MILLIMETERS

## ANT95-L-Z/ANT95-L-Z-PLUS Series ORDERING INFORMATION

### ANT95-L-Z Series Vertical Stage

ANT95-L-Z/ANT95-L-Z-PLUS Aerotech nanotranslation crossed-roller vertical positioner

#### Linear Stage Travel

ANT95-25-L-Z	25 mm (1 in) vertical travel stage with proprietary direct-drive motor technology, 1 Vp-p sinusoidal output linear encoder and limits
ANT95-25-L-Z-PLUS	25 mm (1 in) vertical travel stage with proprietary direct-drive motor technology, 1 Vp-p sinusoidal output linear encoder and limits (High Accuracy Version)
ANT95-50-L-Z	50 mm (2 in) vertical travel stage with proprietary direct-drive motor technology, 1 Vp-p sinusoidal output linear encoder and limits
ANT95-50-L-Z-PLUS	50 mm (2 in) vertical travel stage with proprietary direct-drive motor technology, 1 Vp-p sinusoidal output linear encoder and limits (High Accuracy Version)

#### Options

-RH	Right-hand cable exit
-LH	Left-hand cable exit

# ANT130-L-Z Series

## Single-Axis Z Direct-Drive Nanopositioning Stages

Nanometer performance in a large travel format (35 and 60 mm)

High resolution (2 nm), repeatability (75 nm), and accuracy (300 nm)

In-position stability of <2 nm

Anti-creep crossed-roller bearings

High dynamic performance

nano Motion Technology



### Introduction

Aerotech's ANT series stages are the world's first nanometer-level positioning systems with greater than 25 mm travel. The ANT130-L-Z and ANT130-L-Z-PLUS crossed-roller stages are the best-in-class in combining speed, accuracy, resolution, repeatability, reliability, and size, and are offered in two accuracy grades. As an evolution of the ANT stage family, these linear stages exhibit enhanced motion performance over Aerotech's first generation ANT series.

### Noncontact Direct-Drive

All of the original ANT series' direct-drive advantages have been preserved in the ANT130-L-Z family. Only noncontact direct-drive technology offers the robust, accurate, and high-speed positioning necessary for mass production of precision devices. ANT130-L-Z stages utilize advanced direct-drive technology pioneered by Aerotech to achieve the highest level of positioning performance for high-precision positioning, disk-drive fabrication, fiber alignment, optical delay element actuation, sensor testing, and scanning processes that demand smooth and precise motion.

The ANT130-L-Z stages use a nearly frictionless counterbalance mechanism to maintain performance levels while minimizing motor heating. The counterbalance is user-adjustable from 0 to 10 kg.

### Flexible System Design

The ANT130-L-Z family has universal mounting and tabletop patterns that allow for easy system integration. Two, three, or

more axes can be easily combined for flexible system designs and multi-axis configurations.

### System Characteristics

Outstanding accuracy, position repeatability, and in-position stability require high system resolution. The ANT130-L-Z stage's industry-leading 2 nm minimum incremental step size provides this high level of performance. Excellent in-position stability is assisted by high-quality, anti-creep, crossed-roller bearings. The stage offers virtually maintenance-free operation over the life of the product. Aerotech's direct-drive technology has no hysteresis or backlash, enabling accurate and repeatable nanometer-scale motion.

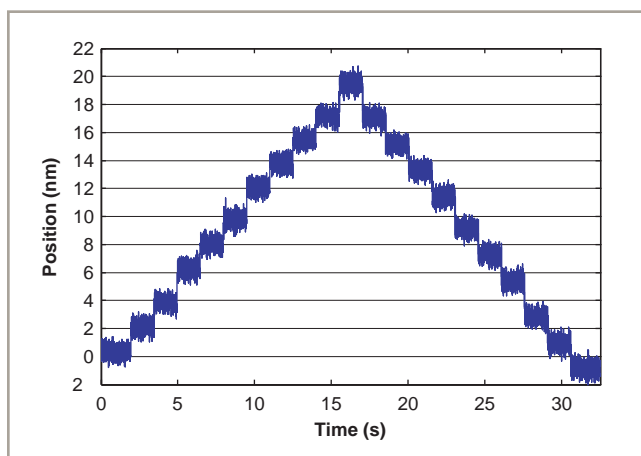

ANT130-60-L-Z-PLUS 2 nm step plot with 100 Hz filter. Best-in-class resolution and exceptional in-position stability for large travel stages.

## ANT130-L-Z/ANT130-L-Z-PLUS Series SPECIFICATIONS

Mechanical Specifications	ANT130-035-L-Z	ANT130-035-L-Z-PLUS	ANT130-060-L-Z	ANT130-060-L-Z-PLUS
Travel	35 mm	35 mm	60 mm	60 mm
Accuracy <sup>(1)</sup>	±3 µm (±120 µin)	±300 nm (±12 µin)	±3 µm (±120 µin)	±300 nm (±12 µin)
Resolution	2 nm (0.08 µin)	2 nm (0.08 µin)	2 nm (0.08 µin)	2 nm (0.08 µin)
Repeatability (Bi-Directional) <sup>(1)</sup>	±100 nm (±4 µin)	±75 nm (±3 µin)	±100 nm (±4 µin)	±75 nm (±3 µin)
Repeatability (Uni-Directional)	±50 nm (±2 µin)	±50 nm (±2 µin)	±50 nm (±2 µin)	±50 nm (±2 µin)
Straightness <sup>(1)</sup>	±2.0 µm (±80 µin)	±2.0 µm (±80 µin)	±2.0 µm (±80 µin)	±2.0 µm (±80 µin)
Flatness <sup>(1)</sup>	±2.0 µm (±80 µin)	±2.0 µm (±80 µin)	±2.0 µm (±80 µin)	±2.0 µm (±80 µin)
Pitch	10 arc sec	10 arc sec	10 arc sec	10 arc sec
Roll	10 arc sec	10 arc sec	10 arc sec	10 arc sec
Yaw	5 arc sec	5 arc sec	5 arc sec	5 arc sec
Maximum Speed	200 mm/s (8 in/s)	200 mm/s (8 in/s)	200 mm/s (8 in/s)	200 mm/s (8 in/s)
Maximum Acceleration	1 g - 10 m/s <sup>2</sup> (No Load)	1 g - 10 m/s <sup>2</sup> (No Load)	1 g - 10 m/s <sup>2</sup> (No Load)	1 g - 10 m/s <sup>2</sup> (No Load)
In-Position Stability <sup>(2)</sup>	<2 nm (<0.08 µin)	<2 nm (<0.08 µin)	<2 nm (<0.08 µin)	<2 nm (<0.08 µin)
Maximum Force (Continuous)	23 N	23 N	23 N	23 N
Load Capacity <sup>(3)</sup>   Vertical	10 kg (22 lb)	10 kg (22 lb)	10 kg (22 lb)	10 kg (22 lb)
Moving Mass	1.2 kg (2.6 lb)	1.2 kg (2.6 lb)	1.4 kg (3.1 lb)	1.4 kg (3.1 lb)
Stage Mass	4.3 kg (9.6 lb)	4.3 kg (9.6 lb)	5.2 kg (11.5 lb)	5.2 kg (11.5 lb)
Material	Aluminum Body/Black Hardcoat Finish			
MTBF (Mean Time Between Failure)	30,000 Hours			

Notes:

- Certified with each stage.
  - In-Position Jitter listing is 3 sigma value.
  - Axis orientation for on-axis loading is listed.
  - Air supply must be clean, dry to 0Å°F dew point and filtered to 0.25 µm or better; recommend nitrogen at 99.9% purity. Supply pressure is determined by the amount of payload carried by the stage.
- Specifications are per axis, measured 25 mm above the tabletop. Performance of multi-axis systems is payload and workpoint dependent. Consult factory for multi-axis or non-standard applications.
  - PLUS requires the use of an Aerotech controller.

Electrical Specifications	ANT130-035-L-Z	ANT130-035-L-Z-PLUS	ANT130-060-L-Z	ANT130-060-L-Z-PLUS
Drive System	Brushless Linear Servomotor			
Feedback	Noncontact Linear Encoder			
Maximum Bus Voltage	±40 VDC			
Limit Switches	5 V, Normally Closed			
Home Switch	Near Center			

Recommended Controller	ANT130-035-L-Z	ANT130-035-L-Z-PLUS	ANT130-060-L-Z	ANT130-060-L-Z-PLUS
Multi-Axis	A3200	Npaq-MXR Npaq MR-MXH Ndrive ML-MXH		
	Ensemble	Epaq-MXH Epaq MR-MXH Ensemble ML-MXH		
Single Axis	Soloist	Soloist ML-MXH		

Notes:

- Linear amplifiers are required to achieve the listed specifications. Other options are available.

Note: To ensure the achievement and repeatability of specifications over an extended period of time, environmental temperature must be controlled to within 0.25°C/24 hours. If this is not possible, alternate products are available. Please consult Aerotech Application Engineering for more information.

# ANT130-L-Z/ANT130-L-Z-PLUS Series PERFORMANCE

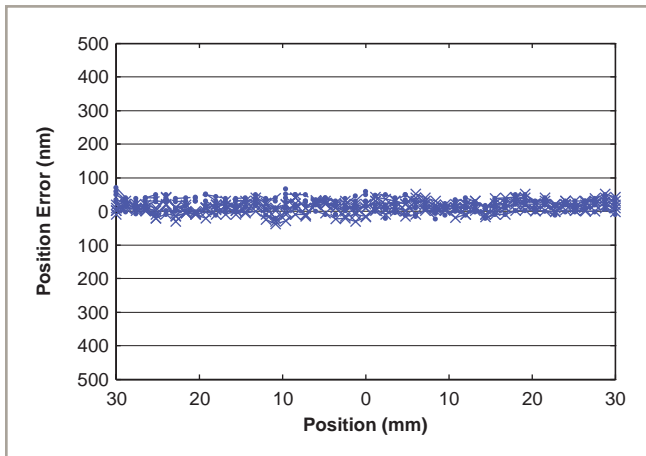

*ANT130-060-L-Z-PLUS accuracy and repeatability, five runs, bi-directional over an extended period of time shows the high level of system accuracy and repeatability.*

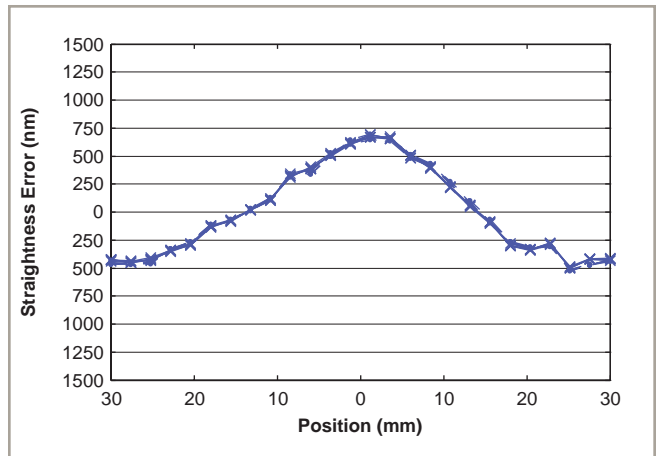

*ANT130-060-L-Z-PLUS straightness error, five runs, bi-directional. Exceptional and highly repeatable performance is assured with minimal straightness error.*

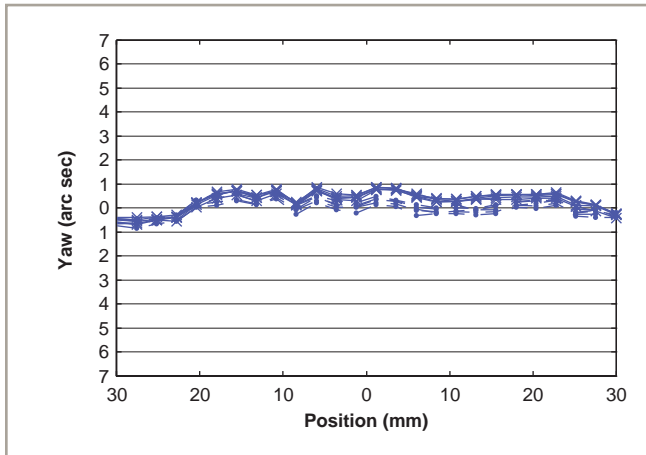

*ANT130-060-L-Z-PLUS yaw, five runs, bi-directional. Highly repeatable, minimal yaw error enhances system positioning accuracy.*

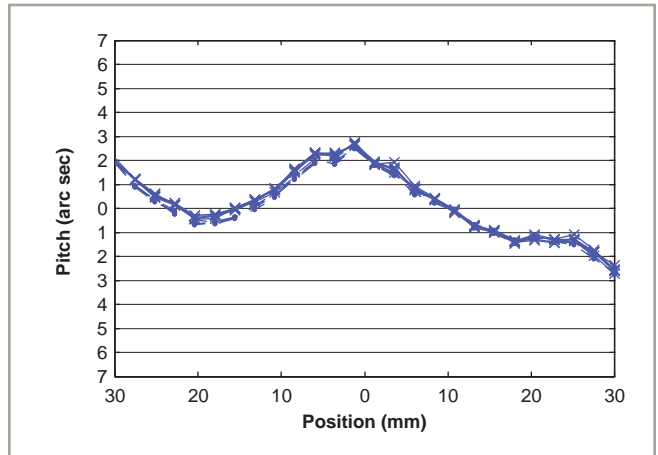

*ANT130-060-L-Z-PLUS pitch, five runs, bi-directional. Excellent repeatability/accuracy contribute to improved processing.*

# ANT130-L-Z/ANT130-L-Z-PLUS DIMENSIONS

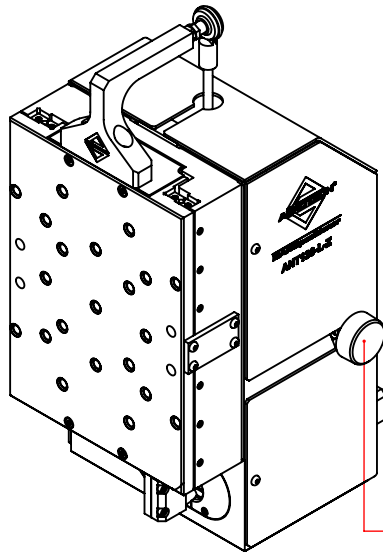
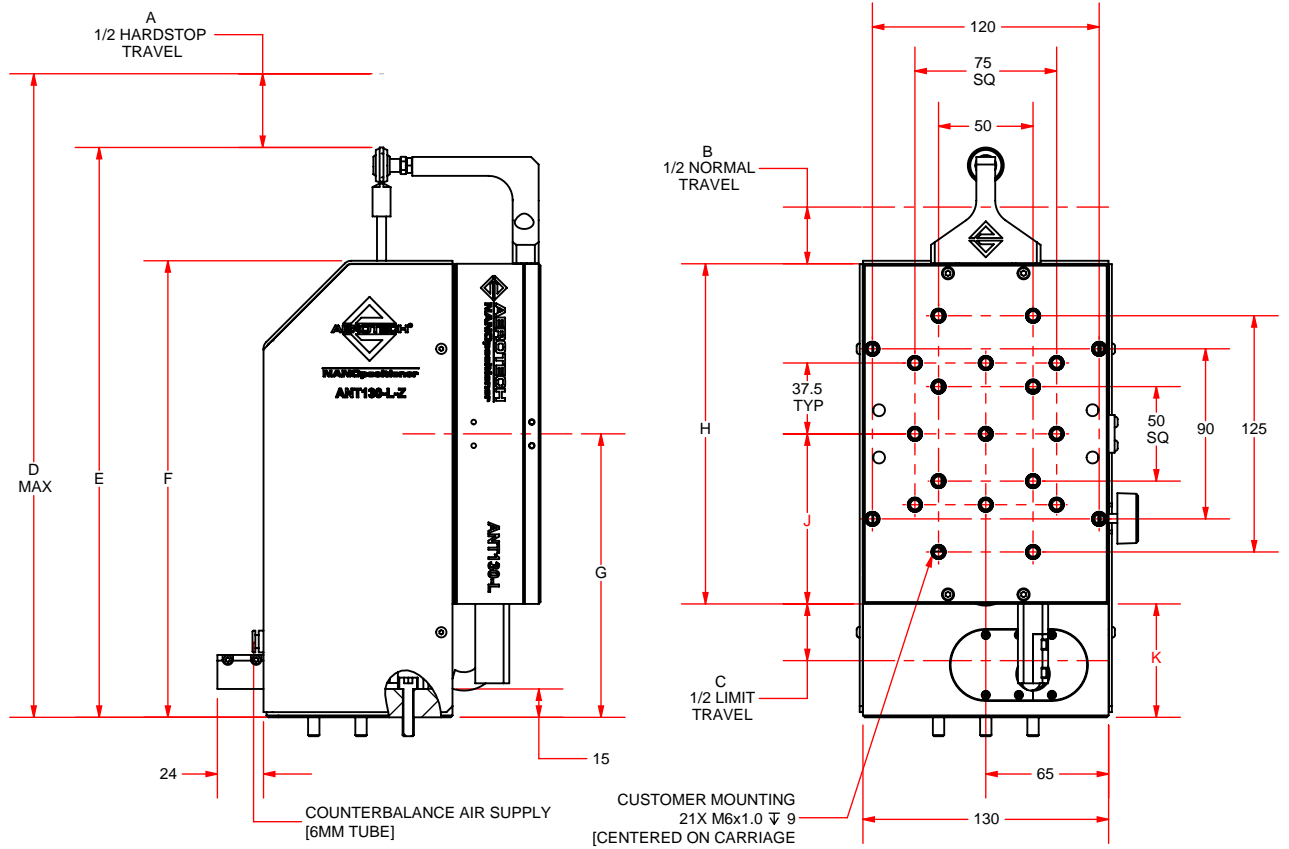

REGULATOR KNOB FOR COUNTERBALANCE ADJUSTMENT

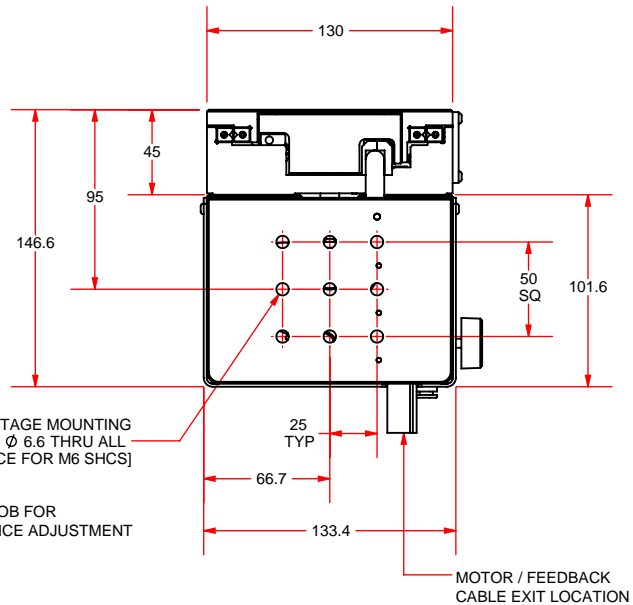

Model	A	B	C	D	E	F	G	H	J	K
ANT130-035-L-Z	25.0	17.5	20.5	278.1	251.6	204.1	125.0	155.0	77.5	47.5
ANT130-060-L-Z	37.5	30.0	33.0	340.6	301.6	241.6	150.0	180.0	90.0	60.0

DIMENSIONS: MILLIMETERS

## ANT130-L-Z/ANT130-L-Z-PLUS Series ORDERING INFORMATION

### ANT130-L-Z Series Vertical Stage

ANT130-L-Z	Aerotech nanotranslation crossed-roller vertical positioner
------------	---

### Linear Stage Travel

ANT130-035-L-Z	35 mm vertical travel stage with proprietary direct-drive motor technology, 1 Vp-p sinusoidal output linear encoder and limits
ANT130-035-L-Z-PLUS	35 mm vertical travel stage with proprietary direct-drive motor technology, 1 Vp-p sinusoidal output linear encoder and limits (High Accuracy Version)
ANT130-060-L-Z	60 mm vertical travel stage with proprietary direct-drive motor technology, 1 Vp-p sinusoidal output linear encoder and limits
ANT130-060-L-Z-PLUS	60 mm vertical travel stage with proprietary direct-drive motor technology, 1 Vp-p sinusoidal output linear encoder and limits (High Accuracy Version)

### Options

-25DU	Single 25-pin D (standard)
-4DU-25DU	Motor 4-pin HPD; feedback 25-pin D

# ANT95-V Series

## Single-Axis Lift Direct-Drive Nanopositioning Stage

Nanometer performance with  
3 mm vertical travel

High resolution (1 nm), repeatability (100 nm),  
and accuracy (200 nm)

In-position stability of <1 nm

Anti-creep crossed-roller bearings

High dynamic performance

nano Motion Technology



### Introduction

Aerotech's ANT series stages are the world's first nanometer-level positioning systems with multi-millimeter travel. The ANT95-V and ANT95-V-PLUS are linear-motor-driven wedge-style vertical lift stages. The stages are designed to be seamlessly integrated with other stages in the ANT95 family for superior multi-axis performance, and are offered in two accuracy grades.

### Noncontact Direct-Drive

All of the original ANT series' direct-drive advantages have been preserved in the ANT95-V family. Only noncontact direct-drive technology offers the robust, accurate, and high-speed positioning necessary for mass production of precision devices. ANT95-V stages utilize advanced direct-drive technology pioneered by Aerotech to achieve the highest level of positioning performance. This direct-drive technology is high-performance, non-cogging, noncontact, high-speed, high-resolution, and high-accuracy. This unique drive and bearing combination, packaged in an extremely small-profile and footprint, offers tangible advantages in many applications such as high-precision positioning, disk-drive fabrication, fiber alignment, optical delay element actuation, sensor testing, and scanning processes that demand smooth and precise motion.

### Flexible System Design

The ANT95-V family has universal mounting and tabletop patterns that allow for easy system integration. Two, three, or more axes can be combined easily for flexible system designs and multi-axis configurations.

### System Characteristics

Outstanding accuracy, position repeatability, and in-position stability require high system resolution. The ANT95-V stage's industry-leading 1 nm minimum incremental step size provides this high level of performance. Excellent in-position stability is assisted by high-quality, anti-creep, crossed-roller bearings. The stage offers virtually maintenance-free operation over the life of the product. Aerotech's direct-drive technology has no hysteresis or backlash, enabling accurate and repeatable nanometer-scale motion.

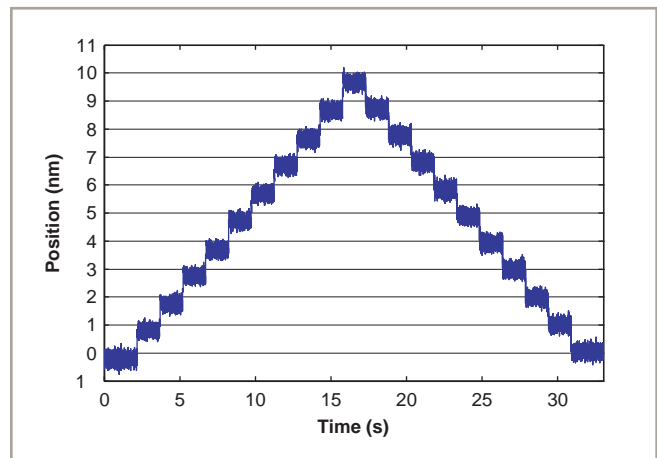

ANT95-3-V-PLUS 1 nm step plot. Best-in-class resolution and exceptional in-position stability for large travel stages.



## ANT95-V/ANT95-V-PLUS Series SPECIFICATIONS

Mechanical Specifications	ANT95-3-V	ANT95-3-V-PLUS
Travel	3 mm	
Accuracy <sup>(1)</sup>	±2 µm (±80 µin)	±200 nm (±8 µin)
Resolution	1 nm (0.04 µin)	
Repeatability (Bi-Directional) <sup>(4)</sup>	±150 nm (±6 µin)	±100 nm (±4 µin)
Repeatability (Uni-Directional)	±75 nm (±3 µin)	
Straightness <sup>(2)</sup>	±1.0 µm (±40 µin)	
Pitch <sup>(1)</sup>	20 arc sec	
Roll <sup>(1)</sup>	10 arc sec	
Yaw <sup>(1)</sup>	10 arc sec	
Maximum Speed	75 mm/s (3 in/s)	
Maximum Acceleration	0.4 g - 4 m/s <sup>2</sup> (No Load)	
Settling Time	See graphs for typical performance	
In-Position Stability <sup>(3)</sup>	<1 nm (<0.04 µin)	
Maximum Force (Continuous)	71 N	
Load Capacity <sup>(4)</sup>	1.5 kg (3.3 lb)	
Moving Mass	1.1 kg (2.42 lb)	
Stage Mass	2.0 kg (4.4 lb)	
Material	Aluminum and Stainless-Steel Body/Black Hardcoat Finish/Black Anodize Finish	
MTBF (Mean Time Between Failure)	30,000 Hours	

Notes:

1. Certified with each stage.
2. Measured perpendicular or parallel to wedge direction.
3. In-Position Stability listing is 3 sigma value.
4. Assumes loading along axis of travel.

• Specifications are per axis, measured 25 mm above the tabletop. Performance of multi-axis systems is payload and workpoint dependent. Consult factory for multi-axis or non-standard applications.

• -PLUS requires the use of an Aerotech controller.

Electrical Specifications	ANT95-3-V
Drive System	Brushless Linear Servomotor
Feedback	Noncontact Linear Encoder
Maximum Bus Voltage	±40 VDC
Limit Switches	5 V, Normally Closed
Home Switch	Near Center

Recommended Controller	ANT95-3-V	
Multi-Axis	A3200	Npaq-MXR Npaq MR-MXH Ndrive ML-MXH
	Ensemble	Epaq-MXH Epaq MR-MXH Ensemble ML-MXH
Single Axis	Soloist	Soloist ML-MXH

Notes:

1. Linear amplifiers are required to achieve the listed specifications. Other options are available.

Note: To ensure the achievement and repeatability of specifications over an extended period of time, environmental temperature must be controlled to within 0.25°C/24 hours. If this is not possible, alternate products are available. Please consult Aerotech Application Engineering for more information.

## ANT95-V/ANT95-V-PLUS Series PERFORMANCE

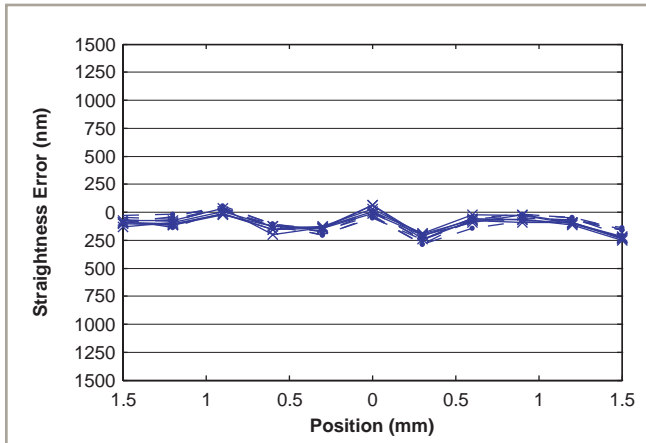

ANT95-3-V-PLUS straightness error, five runs, bi-directional, parallel to the wedge.

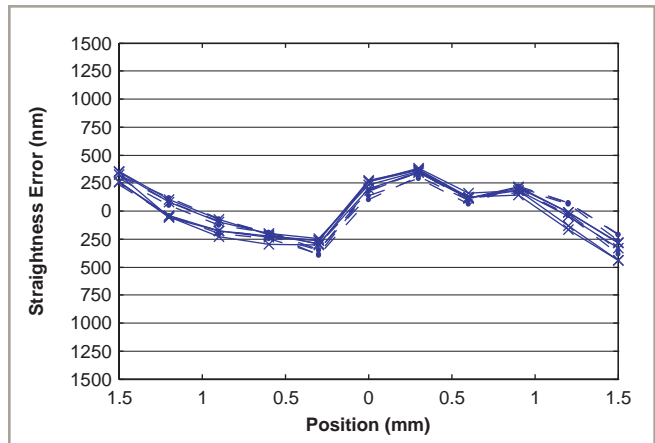

ANT95-3-V-PLUS straightness error, five runs, bi-directional, perpendicular to the wedge.

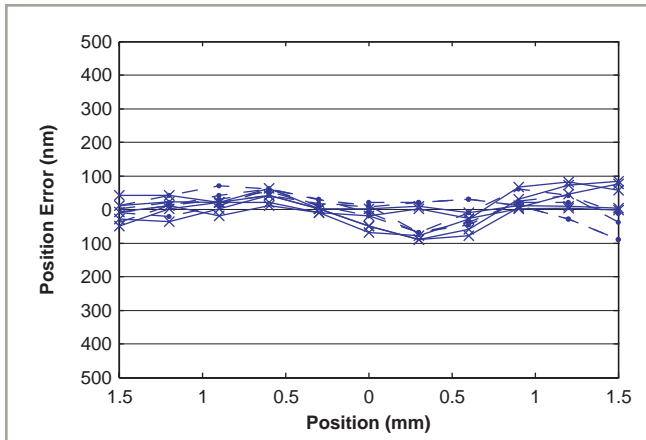

ANT95-3-V-PLUS accuracy and repeatability. This multiple test run over an extended period of time shows the high level of system accuracy and repeatability.

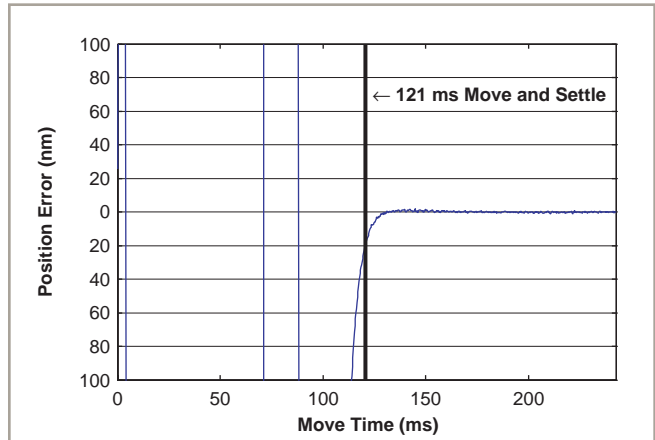

ANT95-3-V-PLUS step and settle performance at 75 mm/s, with a settle spec of  $\pm 20$  nm, and a step size of 3 mm. Outstanding settling time enhances throughput of most applications.

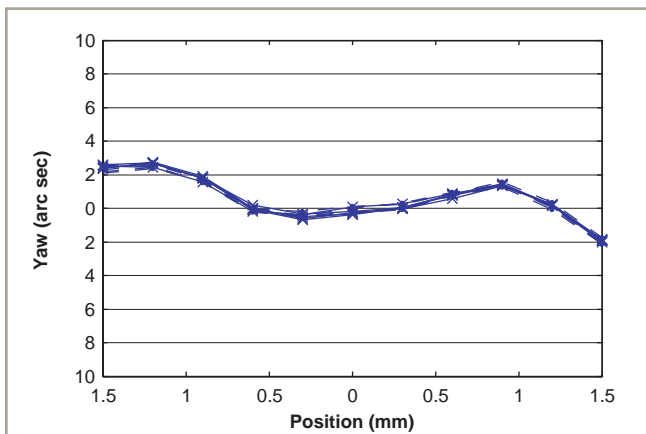

ANT95-3-V-PLUS yaw, five runs, bi-directional. Highly repeatable, minimal yaw error enhances system positioning accuracy.

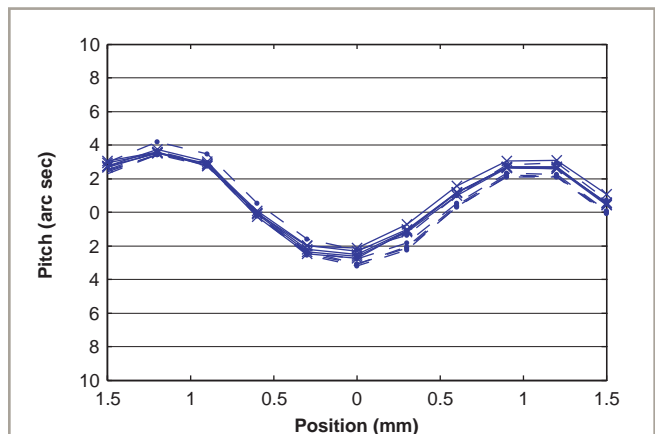

ANT95-3-V-PLUS pitch, five runs, bi-directional. Excellent repeatability/accuracy contribute to improved processing.

# ANT95-3-V/ANT95-3-V-PLUS DIMENSIONS

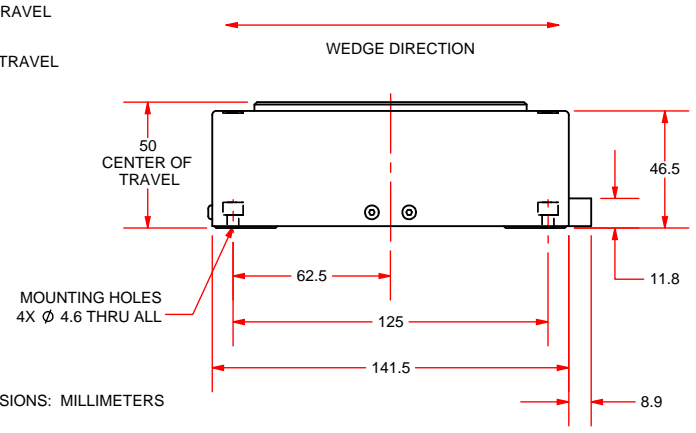
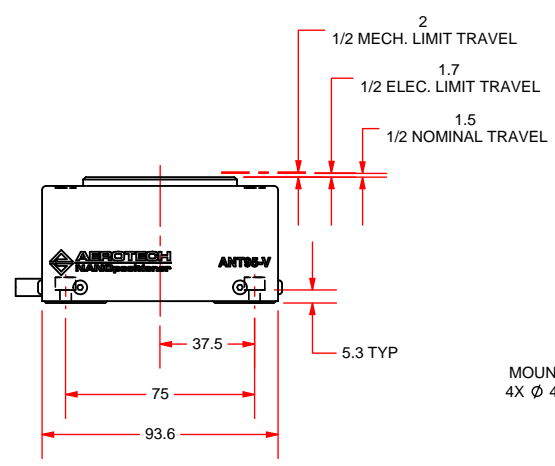
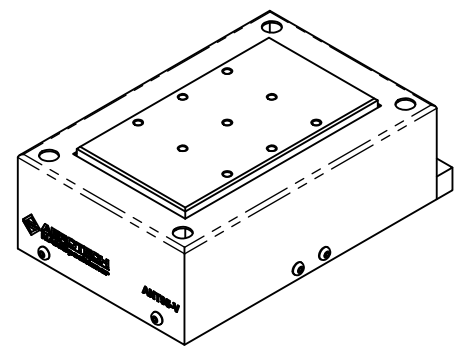
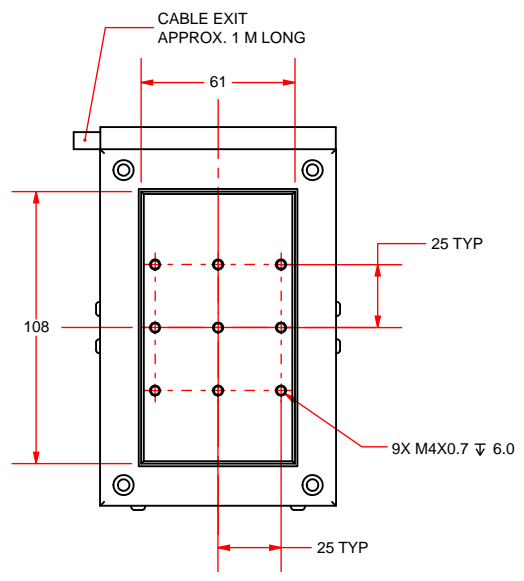

DIMENSIONS: MILLIMETERS

## ANT95-3-V/ANT95-3-V-PLUS Mounting Plate DIMENSIONS

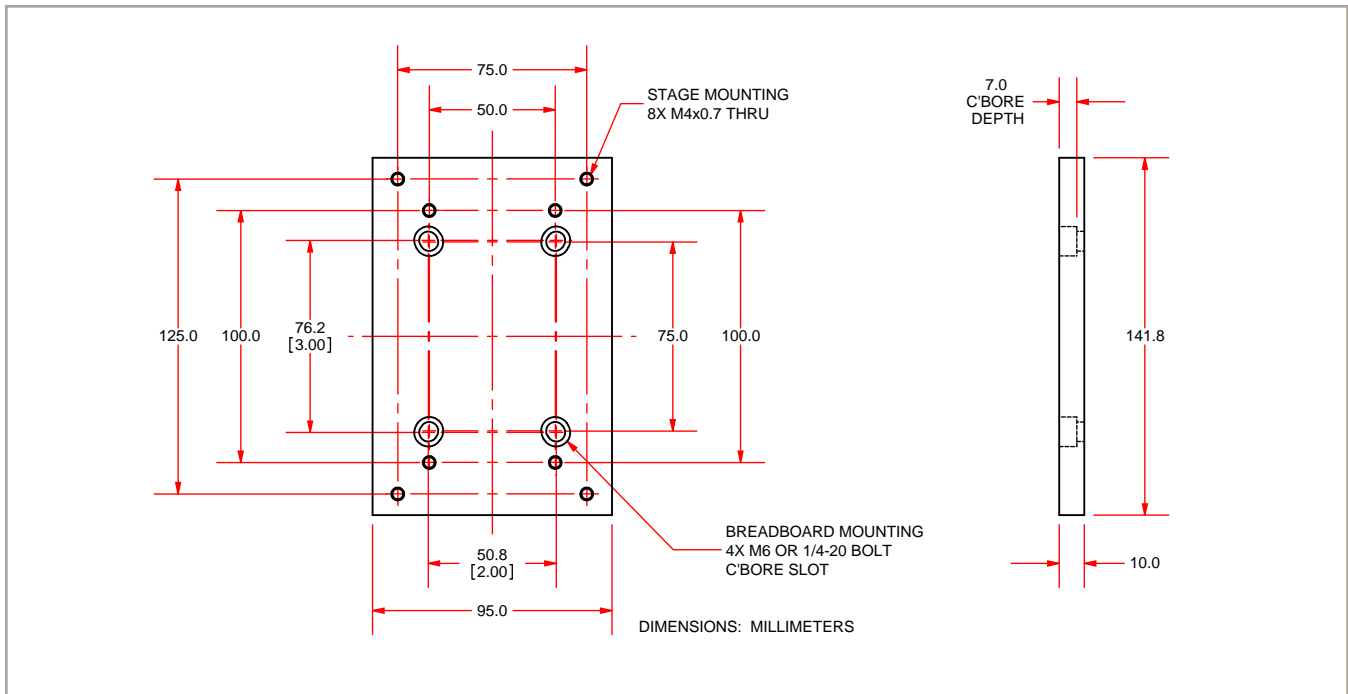

## ANT95-V/ANT95-V-PLUS Series ORDERING INFORMATION

### ANT95-V Series Lift Stage

ANT95-V/ANT95-V-PLUS Aerotech nanotranslation crossed-roller bearing vertical lift positioner

### Linear Stage Travel

ANT95-3-V	3 mm vertical travel lift stage with proprietary direct-drive motor technology, 1 Vp-p sinusoidal output linear encoder and limits
ANT95-3-V-PLUS	3 mm vertical travel lift stage with proprietary direct-drive motor technology, 1 Vp-p sinusoidal output linear encoder and limits (High Accuracy Version)

### Options

-MP	Breadboard mounting plate
-----	---------------------------

# ANT130-V Series

## Single-Axis Lift Direct-Drive Nanopositioning Stage

Nanometer performance with  
5 mm vertical travel

High resolution (2 nm), repeatability (100 nm),  
and accuracy (200 nm)

In-position stability of <2 nm

Anti-creep crossed-roller bearings

High dynamic performance

nano Motion Technology



### Introduction

Aerotech's ANT series stages are the world's first nanometer-level positioning systems with multi-millimeter travel. The ANT130-V and ANT130-V-PLUS are linear-motor-driven wedge-style vertical lift stages. The stages are designed to be seamlessly integrated with other stages in the ANT130 family for superior multi-axis performance, and are offered in two accuracy grades.

### Noncontact Direct-Drive Design

All of the original ANT series' direct-drive advantages have been preserved in the ANT130-V family. Only noncontact direct-drive technology offers the robust, accurate, and high-speed positioning necessary for mass production of precision devices. ANT130-V stages utilize advanced direct-drive technology pioneered by Aerotech to achieve the highest level of positioning performance. This direct-drive technology is high-performance, non-cogging, noncontact, high-speed, high-resolution, and high-accuracy. This unique drive and bearing combination, packaged in an extremely small-profile and footprint, offers tangible advantages in many applications such as high-precision positioning, disk-drive fabrication, fiber alignment, optical delay element actuation, sensor testing, and scanning processes that demand smooth and precise motion.

### Flexible System Design

The ANT130-V family has universal mounting and tabletop patterns that allow for easy system integration. Two, three, or more axes can be combined easily for flexible system designs and multi-axis configurations.

### System Characteristics

Outstanding accuracy, position repeatability, and in-position stability require high system resolution. The ANT130-V stage's industry-leading 2 nm minimum incremental step size provides this high level of performance. Excellent in-position stability is assisted by high-quality, anti-creep, crossed-roller bearings. The stage offers virtually maintenance-free operation over the life of the product. Aerotech's direct-drive technology has no hysteresis or backlash, enabling accurate and repeatable nanometer-scale motion.

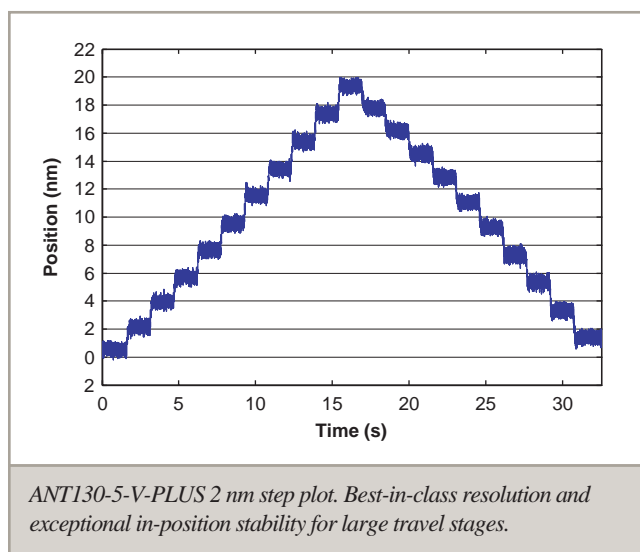

## ANT130-V/ANT130-V-PLUS Series SPECIFICATIONS

Mechanical Specifications	ANT130-5-V	ANT130-5-V-PLUS
Travel	5 mm	
Accuracy <sup>(1)</sup>	±2 µm (± 80 µin)	±200 nm (± 8 µin)
Resolution	2 nm (± 0.08 µin)	
Repeatability (Bi-Directional) <sup>(4)</sup>	±150 nm (± 6 µin)	±100 nm (± 4 µin)
Repeatability (Uni-Directional)	±75 nm (± 3 µin)	
Straightness <sup>(2)</sup>	±1.0 µm (±40 µin)	
Pitch <sup>(1)</sup>	20 arc sec	
Roll	10 arc sec	
Yaw <sup>(1)</sup>	10 arc sec	
Maximum Speed	75 mm/s (3 in/s)	
Maximum Acceleration	0.7 g - 7 m/s <sup>2</sup> (No Load)	
Settling Time	See graphs for typical performance	
In-Position Stability <sup>(3)</sup>	<2 nm (<0.08 µin)	
Maximum Force (Continuous)	100 N	
Load Capacity <sup>(4)</sup>	3.0 kg (6.6 lb)	
Moving Mass	1.8 kg (4 lb)	
Stage Mass	3.1 kg (7 lb)	
Material	Aluminum Body/Black Hardcoat Finish/Black Anodize Finish	
MTBF (Mean Time Between Failure)	30,000 Hours	

Notes:

1. Certified with each stage.
  2. Measured perpendicular or parallel to wedge direction.
  3. In-Position Stability listing is 3 sigma value.
  4. Assumes loading along axis of travel.
- Specifications are per axis, measured 25 mm above the tabletop. Performance of multi-axis systems is payload and workpoint dependent. Consult factory for multi-axis or non-standard applications.
  - -PLUS requires the use of an Aerotech controller.

Electrical Specifications	ANT130-5-V
Drive System	Brushless Linear Servomotor
Feedback	Noncontact Linear Encoder
Maximum Bus Voltage	±40 VDC
Limit Switches	5 V, Normally Closed
Home Switch	Near Center

Recommended Controller	ANT130-5-V	
Multi-Axis	A3200	Npaq-MXR Npaq MR-MXH Ndrive ML-MXH
	Ensemble	Epaq-MXH Epaq MR-MXH Ensemble ML-MXH
Single Axis	Soloist	Soloist ML-MXH

Notes:

1. Linear amplifiers are required to achieve the listed specifications. Other options are available.

Note: To ensure the achievement and repeatability of specifications over an extended period of time, environmental temperature must be controlled to within 0.25°C/24 hours. If this is not possible, alternate products are available. Please consult Aerotech Application Engineering for more information.

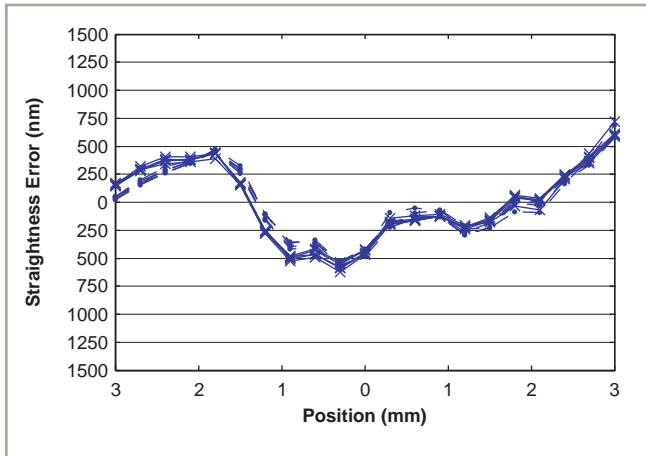

ANT130-5-V-PLUS straightness error, five runs, bi-directional, parallel to the wedge.

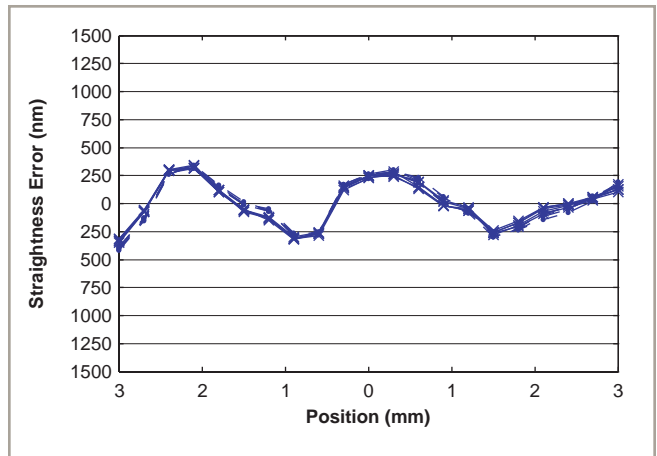

ANT130-5-V-PLUS straightness error, five runs, bi-directional, perpendicular to the wedge.

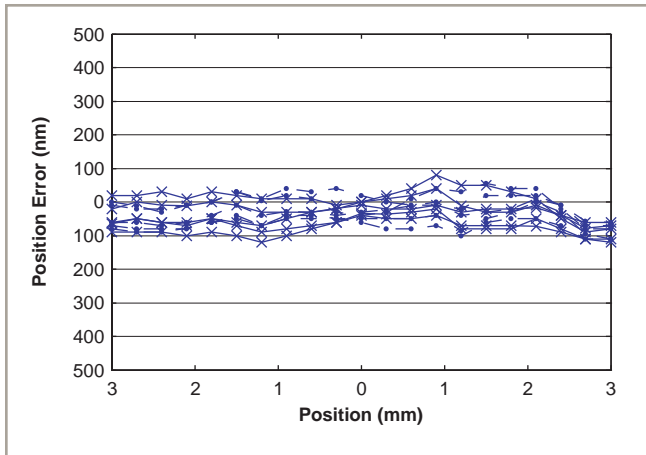

ANT130-5-V-PLUS accuracy and repeatability. This multiple test run over an extended period of time shows the high level of system accuracy and repeatability.

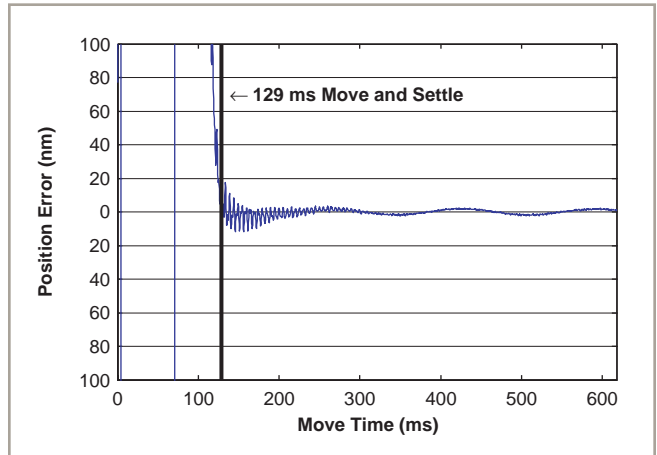

ANT130-5-V-PLUS step and settle performance at 75 mm/s, with a settle spec of  $\pm 20$  nm, and a step size of 5 mm. Outstanding settling time enhances throughput of most applications.

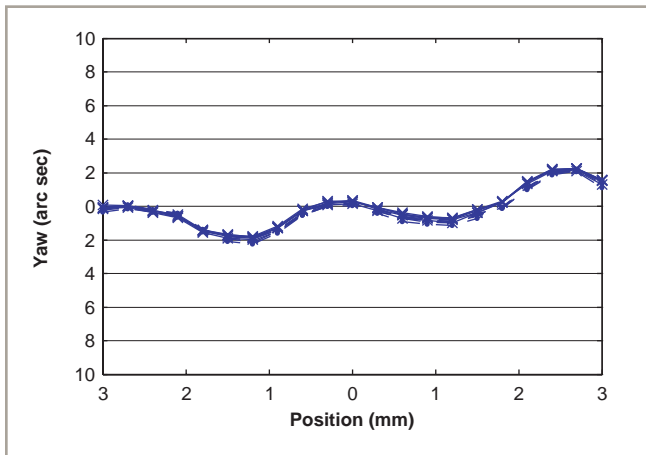

ANT130-5-V-PLUS yaw, five runs, bi-directional. Highly repeatable, minimal yaw error enhances system positioning accuracy.

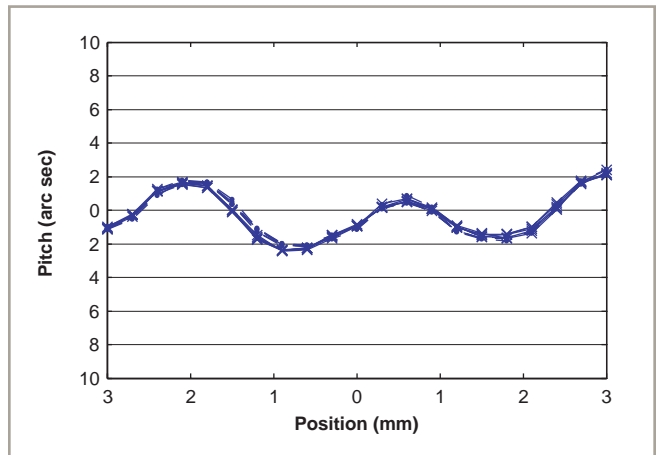

ANT130-5-V-PLUS pitch, five runs, bi-directional. Excellent repeatability/accuracy contribute to improved processing.

ANT130-5-V/ANT130-5-V-PLUS DIMENSIONS

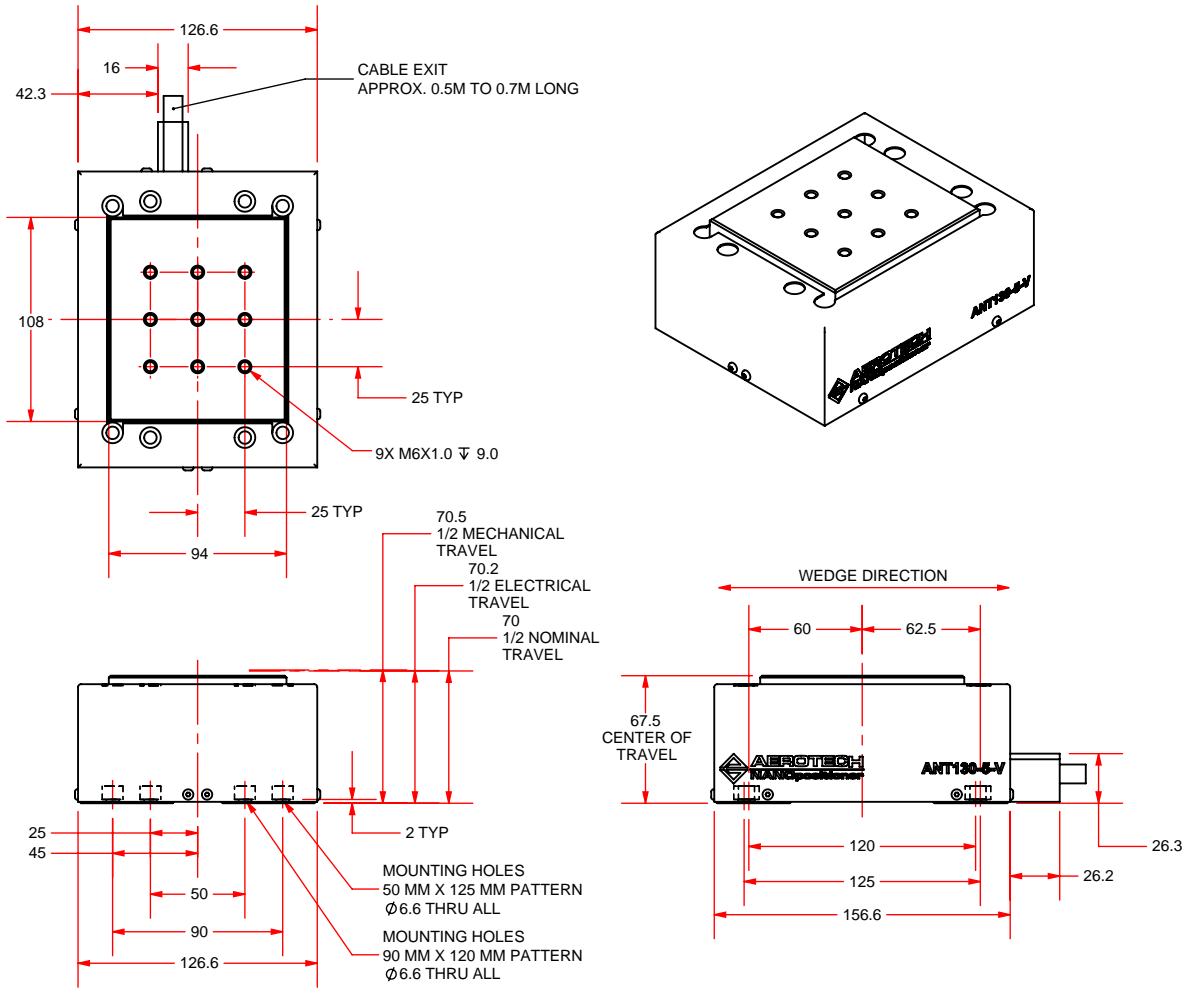



## ANT130-5-V/ANT130-5-V-PLUS Mounting Plate DIMENSIONS

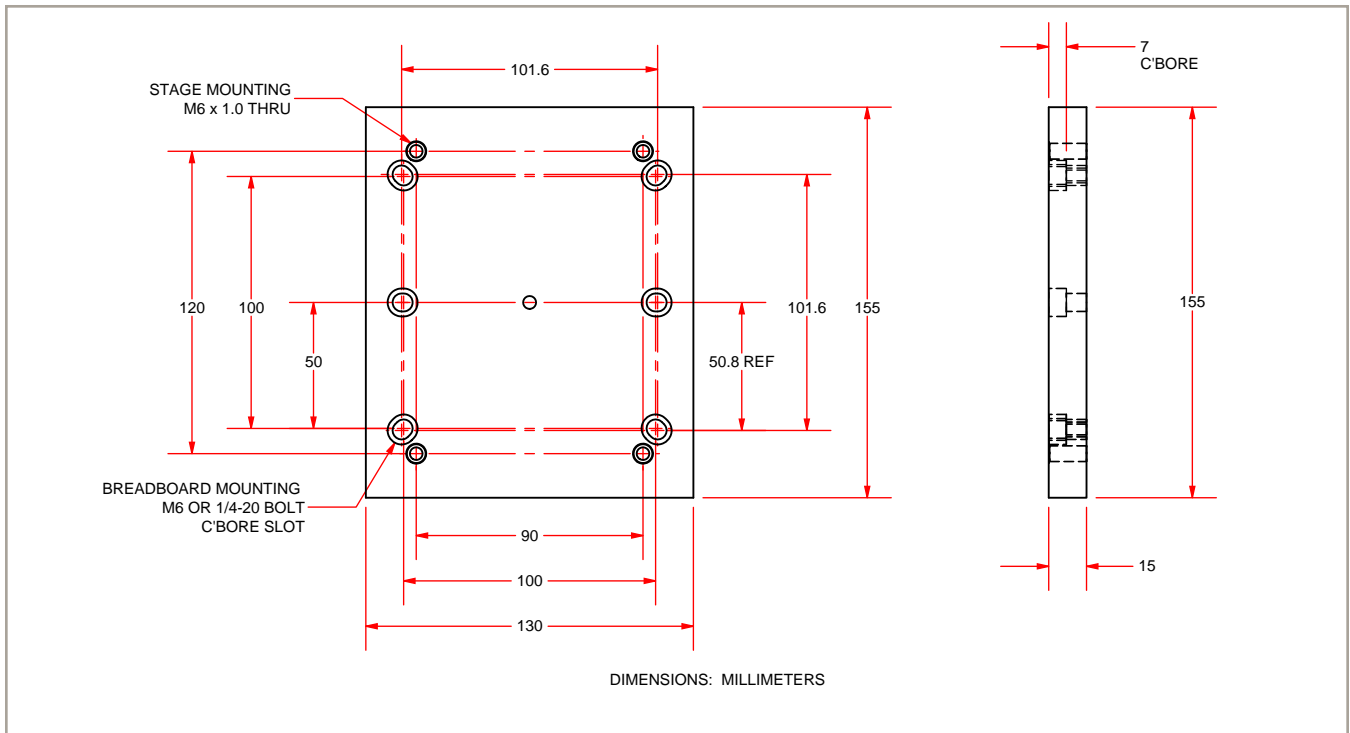

## ANT130-V/ANT130-V-PLUS Series ORDERING INFORMATION

### ANT130-V Series Lift Stage

ANT130-V/ANT130-V-PLUS Aerotech nanotranslation crossed-roller bearing vertical lift positioner

### Linear Stage Travel

ANT130-5-V	5 mm vertical travel lift stage with proprietary direct-drive motor technology, 1 Vp-p sinusoidal output linear encoder and limits
ANT130-5-V-PLUS	5 mm vertical travel lift stage with proprietary direct-drive motor technology, 1 Vp-p sinusoidal output linear encoder and limits (High Accuracy Version)

### Output Cable Connectors

-25DU	Single 25-pin D connector (standard)
-4DU-25DU	4-pin HPD and 25-pin D connectors

Note: -25DU single 25-pin connector option not valid for systems using bus voltages greater than 80 V

### Options

-MP	Breadboard mounting plate
-----	---------------------------

# ANT-20G Series

## Direct-Drive Goniometers

Noncontact, non-cogging, frictionless direct-drive for zero backlash or hysteresis

High speed ( $150^\circ/\text{s}$ )

High resolution (0.05 arc second)

Excellent in-position stability

Large  $20^\circ$  rotation angle

Orthogonal mounting of two cradles provides rotation about the same point

No maintenance

Compact design

## nano Motion Technology



Clockwise from upper left: ANT-20G-50 mounted in an orthogonal configuration with an ANT-20G-90, ANT-20G-110, and an ANT-20G-160.

U.S. Patent No. 6,442,851

Aerotech's ANT-20G goniometers represent a significant breakthrough in the high-accuracy angular alignment of components. This unique design utilizes Aerotech's best-in-class direct-drive noncontact motor technology. When used with Aerotech's controllers, the ANT-20G series provides an industry-leading positioning speed of 150 degrees per second.

High-precision bearings, direct on-axis encoder feedback, and noncontact and noncogging direct-drive technology assure the highest level of performance and make excellent repeatability and in-position stability a reality. The goniometer cradles can be mounted orthogonally to provide pitch and roll about the same point in space. Combining this with a rotary stage under the orthogonal assembly adds a third rotation axis (pitch, roll, yaw) through the same point.

The critical elements of the ANT-20G goniometers, as with all other ANT series nanopositioners, were selected to operate in a 24/7 manufacturing environment. Unlike worm- or piezo-driven goniometers, the ANT-20G series will not require periodic adjustment or maintenance. This will assure many years of trouble-free operation. The ANT-20G cradles are available in four sizes.

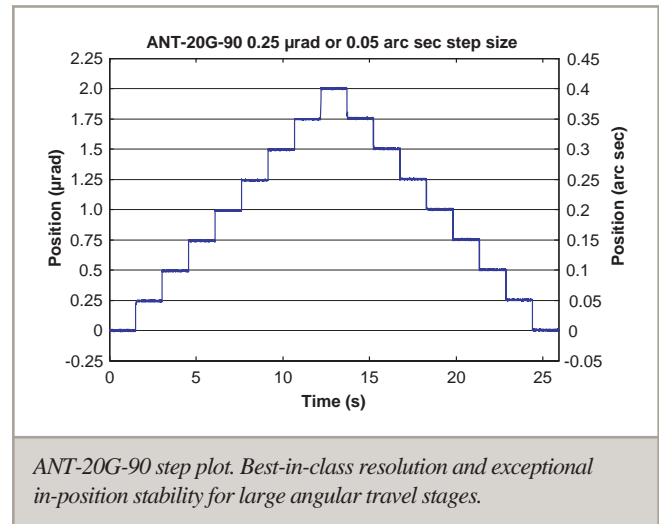

## ANT-20G Series SPECIFICATIONS

Mechanical Specifications		ANT-20G-50	ANT-20G-90
Rotation Angle		20°	20°
Accuracy <sup>(1)</sup>		±90 µrad (±18 arc sec)	±50 µrad (±10 arc sec)
Resolution		0.25 µrad (0.05 arc sec)	0.25 µrad (0.05 arc sec)
Repeatability (Bi-Directional) <sup>(1)</sup>		±18 µrad (±4 arc-sec)	±10 µrad (±2 arc-sec)
Repeatability (Uni-Directional)		±5 µrad (±1 arc-sec)	±5 µrad (±1 arc-sec)
Tilt Error Motion		±90 µrad (±18 arc sec)	±50 µrad (±10 arc sec)
Maximum Speed		150 degrees per second	
Maximum Acceleration		1200 rad/s <sup>2</sup>	500 rad/s <sup>2</sup>
Settling Time		See graph for typical performance	
In-Position Stability <sup>(2)</sup>		±0.4 µrad (±0.08 arc sec)	±0.2 µrad (±0.04 arc sec)
Nominal Radius of Rotation		50 mm	90 mm
Height from Tabletop to Rotation Point		19.1 mm	57.5 mm
Maximum Torque (Continuous)		0.40 N-m	0.85 N-m
Load Capacity	Axial	1.5 kg	2.0 kg
	Moment	60 kg-mm	80 kg-mm
Stage Mass		0.55 kg (1.2 lb)	1.1 kg (2.4 lb)
Material		Aluminum	
MTBF (Mean Time Between Failure)		30,000 Hours	

Notes:

1. Certified with each stage.

2. In-Position Jitter listing is 3 sigma value.

• Specifications are per axis, measured at the rotation point. Performance of multi-axis systems is payload and workpoint dependent. Consult factory for multi-axis or non-standard applications.

Mechanical Specifications		ANT-20G-110	ANT-20G-160
Rotation Angle		20°	20°
Accuracy <sup>(1)</sup>		±40 µrad (±8 arc sec)	±30 µrad (±6 arc sec)
Resolution		0.25 µrad (0.05 arc sec)	0.25 µrad (0.05 arc sec)
Repeatability (Bi-Directional) <sup>(1)</sup>		±10 µrad (±2 arc-sec)	±10 µrad (±2 arc-sec)
Repeatability (Uni-Directional)		±5 µrad (±1 arc-sec)	±5 µrad (±1 arc-sec)
Tilt Error Motion		±40 µrad (±8 arc sec)	±30 µrad (±6 arc sec)
Maximum Speed		150 degrees per second	
Maximum Acceleration		375 rad/s <sup>2</sup>	250 rad/s <sup>2</sup>
Settling Time		See graph for typical performance	
In-Position Stability <sup>(2)</sup>		±0.2 µrad (±0.04 arc sec)	±0.15 µrad (±0.03 arc sec)
Nominal Radius of Rotation		110 mm	160 mm
Height from Tabletop to Rotation Point		76.2 mm	120.4 mm
Maximum Torque (Continuous)		1.00 N-m	2.40 N-m
Load Capacity	Axial	2.0 kg	3.5 kg
	Moment	80 kg-mm	140 kg-mm
Stage Mass		1.2 kg (2.6 lb)	1.6 kg (3.5 lb)
Material		Aluminum	
MTBF (Mean Time Between Failure)		30,000 Hours	

Notes:

1. Certified with each stage.

2. In-Position Jitter listing is 3 sigma value.

• Specifications are per axis, measured at the rotation point. Performance of multi-axis systems is payload and workpoint dependent. Consult factory for multi-axis or non-standard applications.

Note: To ensure the achievement and repeatability of specifications over an extended period of time, environmental temperature must be controlled to within 0.25°C/24 hours. If this is not possible, alternate products are available. Please consult Aerotech Application Engineering for more information.

## ANT-20G Series SPECIFICATIONS

Electrical Specifications	ANT-20G-50	ANT-20G-90	ANT-20G-110	ANT-20G-160
Drive System	Slotless, Brushless, Direct-Drive			
Feedback	Noncontact Encoder			
Maximum Bus Voltage	±40 VDC			
Limit Switches	5 V, Normally Closed			
Home Switch	Near Center			

Recommended Controller	ANT-20G-50	ANT-20G-90	ANT-20G-110	ANT-20G-160
Multi-Axis	A3200	Npaq-MXR Npaq MR-MXH Ndrive ML-MXH		
	Ensemble	Epaq-MXH Epaq MR-MXH Ensemble ML-MXH		
Single Axis	Soloist	Soloist ML-MXH		

Notes:

1. Linear amplifiers are required to achieve the listed specifications. Other options are available.

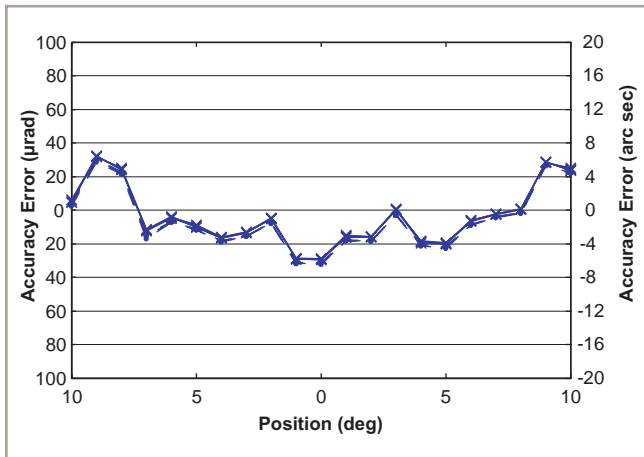

ANT-20G-90 accuracy, five runs, bi-directional, uncalibrated, shows the high level of system accuracy.

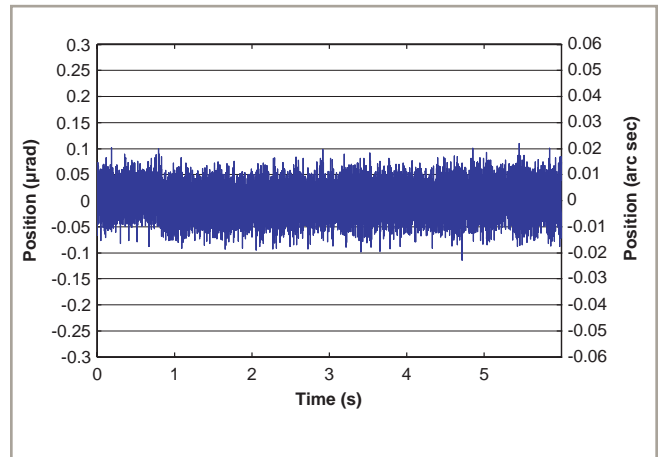

ANT-20G-90 in-position stability. Excellent in-position stability is another feature of the ANT Series goniometers.

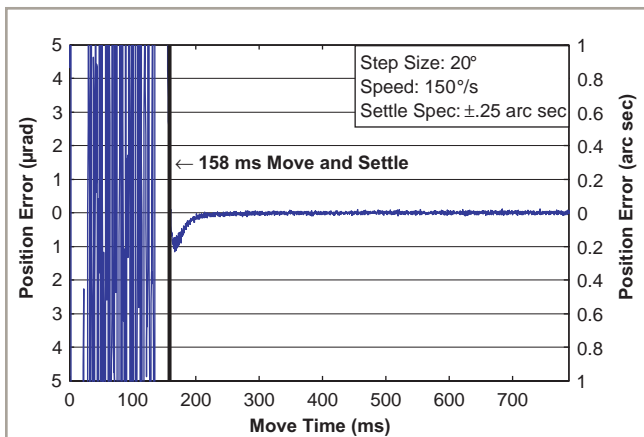

ANT-20G-90 step and settle performance. Outstanding settling time enhances throughput of most applications.

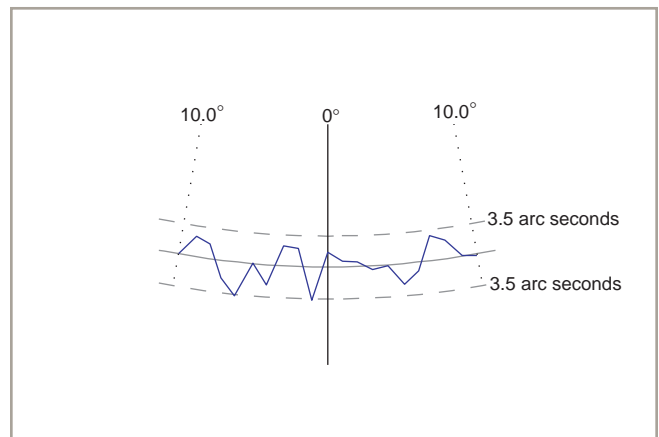

ANT-20G-90 tilt error motion performance.

# ANT-20G DIMENSIONS

## ANT-20G-50

U.S. Patent No. 6,442,851

All stages shown at center of rotation angle.

Mounting surface quality: Flatness = 5  $\mu\text{m}$  [0.0002 in.]

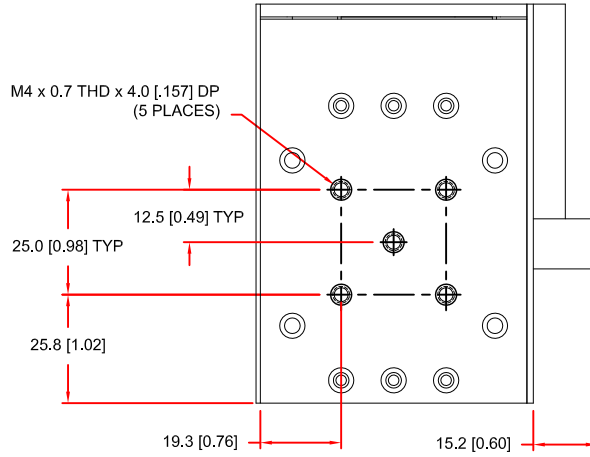

### DIMENSIONS - MILLIMETERS [INCHES]

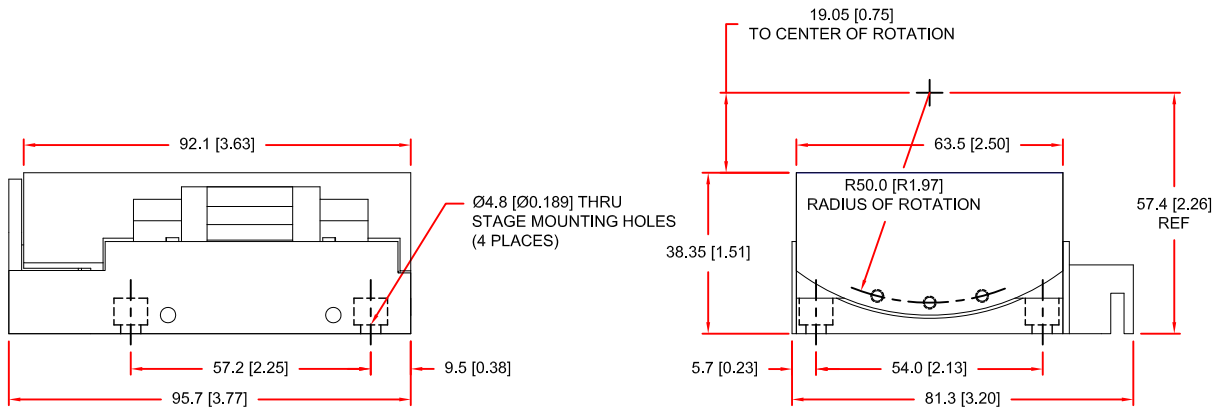

# ANT-20G DIMENSIONS

## ANT-20G-90

U.S. Patent No. 6,442,851

All stages shown at center of rotation angle.

Mounting surface quality: Flatness = 5 μm [0.0002 in.]

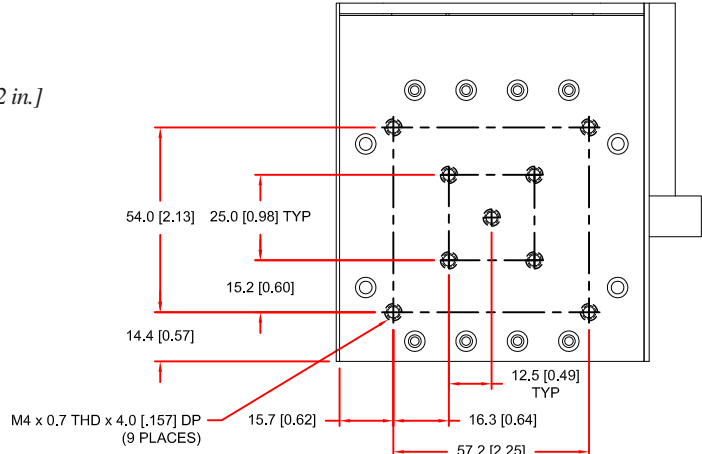

DIMENSIONS - MILLIMETERS [INCHES]

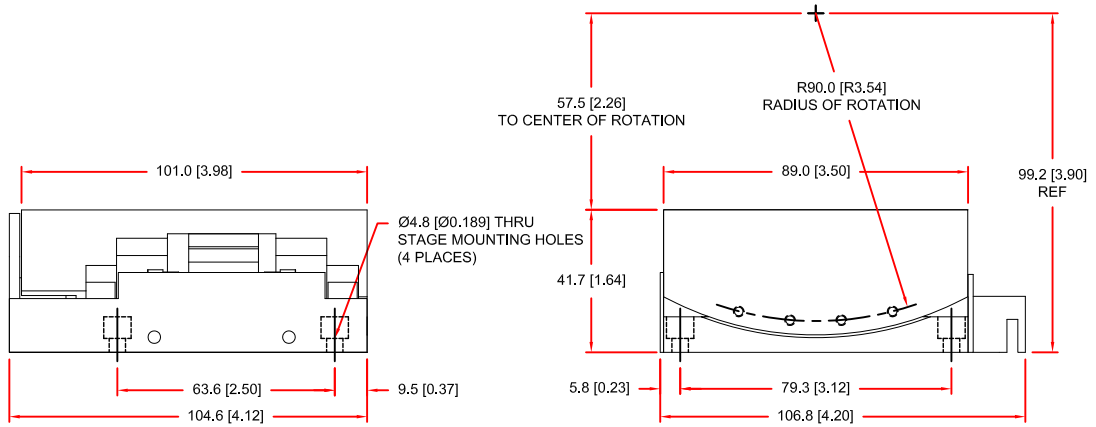

## ANT-20G-50-90

## ANT-20G-50/90

SEE ANT-20G-50 FOR TABLETOP DIMENSIONS

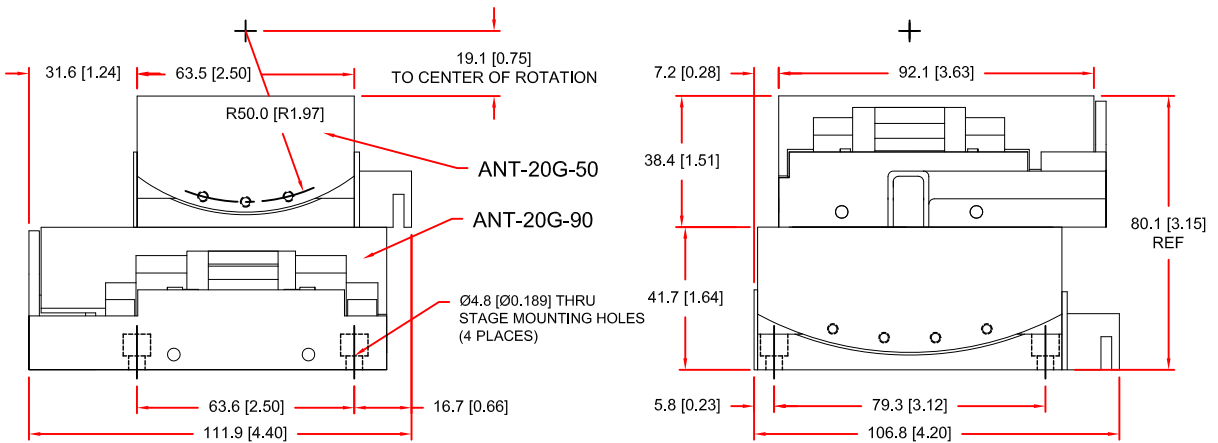

U.S. Patent No. 6,442,851

All stages shown at center of rotation angle. Mounting surface quality: Flatness = 5 μm [0.0002 in.]

# ANT-20G DIMENSIONS

## ANT-20G-110

U.S. Patent No. 6,442,851

All stages shown at center of rotation angle.

Mounting surface quality: Flatness = 5 μm [0.0002 in.]

M4 x 0.7 THD x 4.0 [1.57] DP  
(5 PLACES)

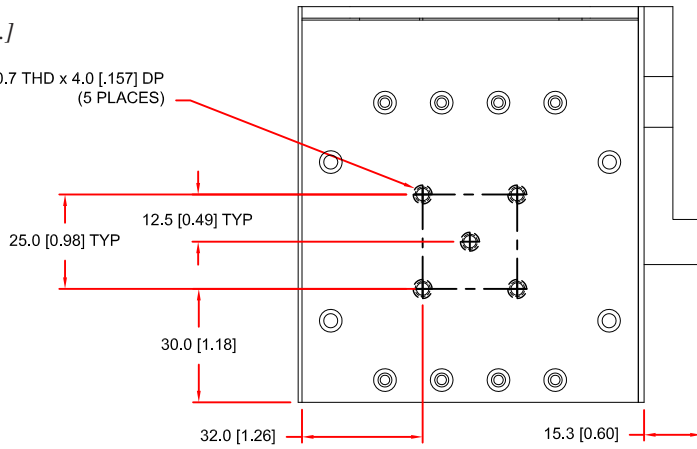

### DIMENSIONS - MILLIMETERS [INCHES]

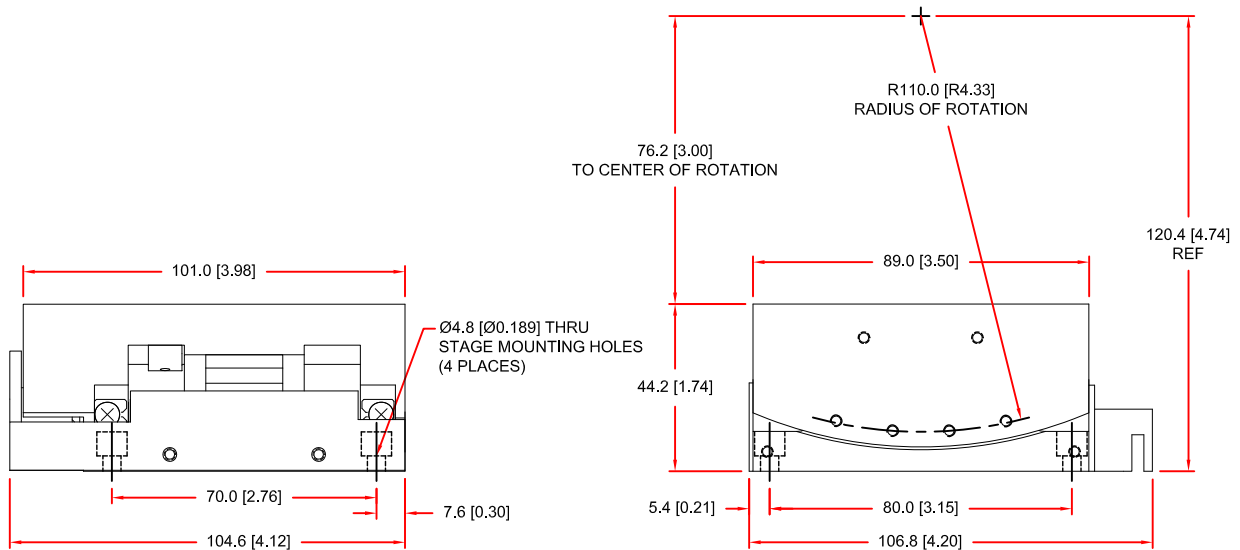

# ANT-20G DIMENSIONS

## ANT-20G-160

U.S. Patent No. 6,442,851

All stages shown at center of rotation angle.

Mounting surface quality: Flatness = 5 μm [0.0002 in.]

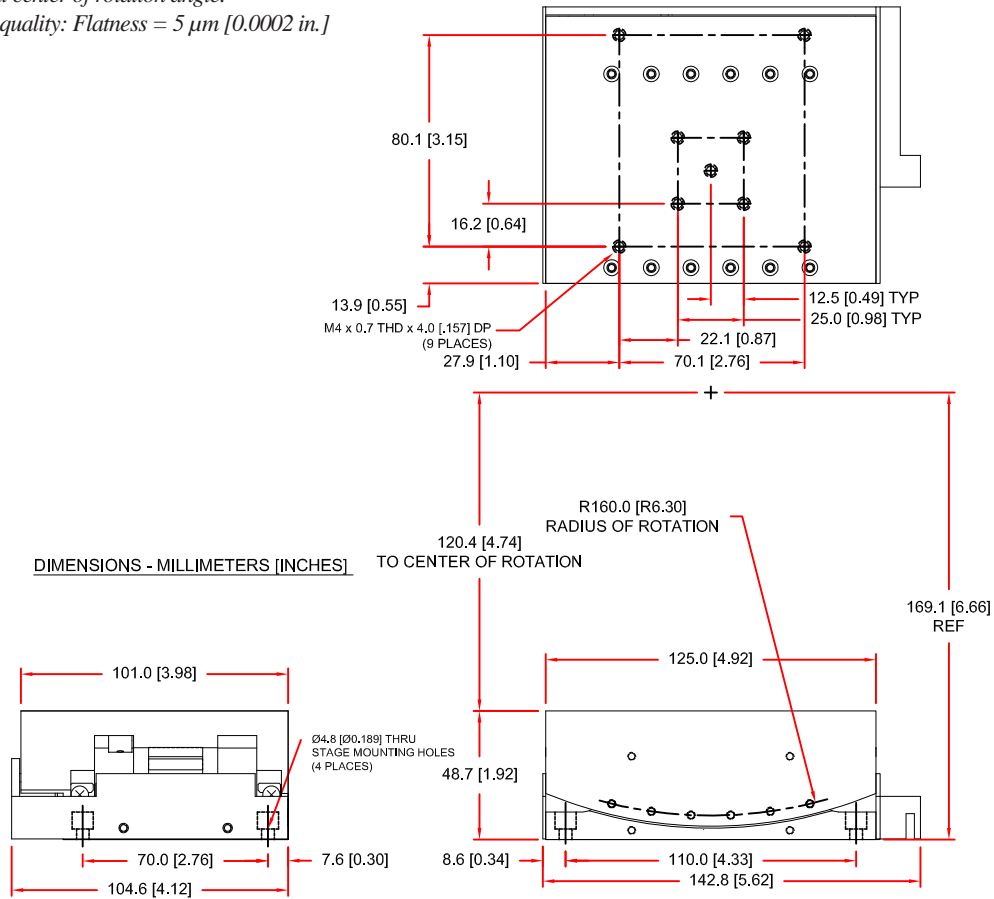

## ANT-20G-110-160

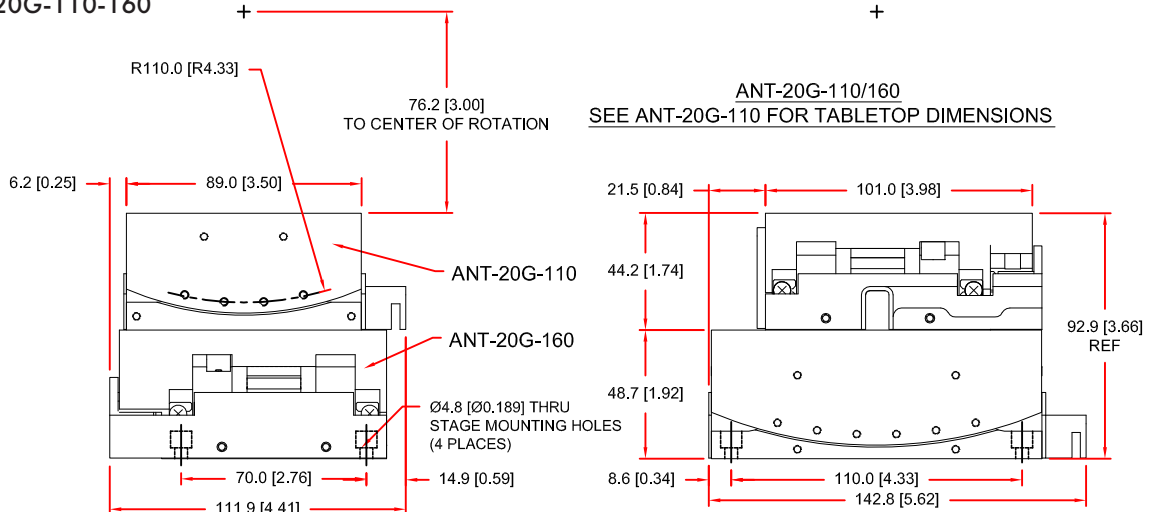

U.S. Patent No. 6,442,851

All stages shown at center of rotation angle. Mounting surface quality: Flatness = 5 μm [0.0002 in.]



## ANT-20G Series ORDERING INFORMATION

### ANT-20G Series Goniometer

ANT-20G-50	20 degree angle of rotation goniometer with proprietary direct-drive motor technology, 50 mm radius of rotation, limits, 1 Vpp sinusoidal encoder, 1 meter cable, 25 D connector
ANT-20G-90	20 degree angle of rotation goniometer with proprietary direct-drive motor technology, 90 mm radius of rotation, limits, 1 Vpp sinusoidal encoder, 1 meter cable, 25 D connector
ANT-20G-110	20 degree angle of rotation goniometer with proprietary direct-drive motor technology, 110 mm radius of rotation, limits, 1 Vpp sinusoidal encoder, 1 meter cable, 25 D connector
ANT-20G-160	20 degree angle of rotation goniometer with proprietary direct-drive motor technology, 160 mm radius of rotation, limits, 1 Vpp sinusoidal encoder, 1 meter cable, 25 D connector

# Nano Motion Control Systems

Aerotech Nano Motion Control Systems are designed specifically for nanometer positioning over long travels. Each of the key controller technologies – linear amplifiers, high-precision multiplier feedback electronics, and dynamic trajectory management – are all essential to achieving nanometer motion. While the technology used to make a one nanometer step is complex, the Aerotech software, Motion Composer, makes the system setup, debug, and commissioning easy.

## Software

Use the libraries and example code to develop your own front-end and applications with .NET, C#, C, and LabVIEW®.

- Easy setup with calculators and autotune routine
- Use state-of-the-art Integrated Development Environment (IDE) to develop your motion program
- Second-to-none diagnostics toolkit
- Conditional 2D error plotting

## Automation 3200



- Software-based machine controller
- 1 to 32 axes of coordinated motion
- Up to 32 tasks
- PC-based
- AeroBasic™ programming language
- Linear power stage
- Advanced features for demanding applications
- Discrete or rackmount
- X65536 interpolation
- Sub-nanometer resolution
- Analog and digital I/O

## Ensemble



- Stand-alone 1- to 10-axis controller
- Versatile, cost-effective, coordinated motion
- Up to 4 tasks
- Linear power stage
- Desktop or panel mount

## Integrated Development Environment

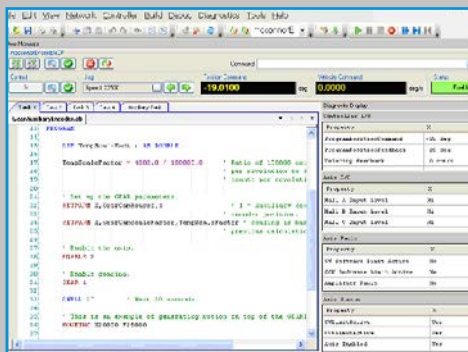

Programming Interface

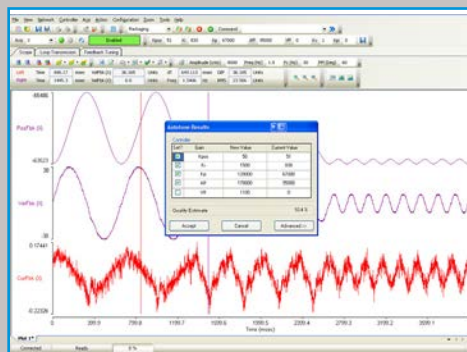

Autotune

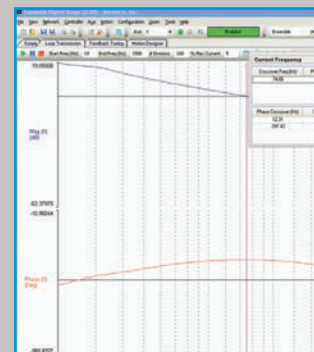

Loop Transmission

### Dynamic Controls Toolbox

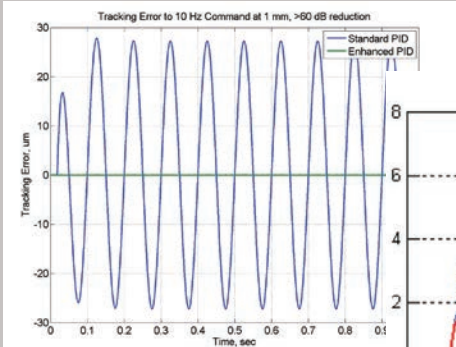

Harmonic Cancellation

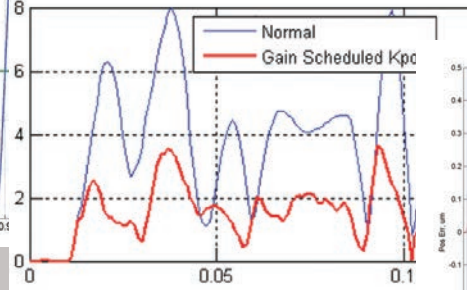

Directional Gain Scheduling

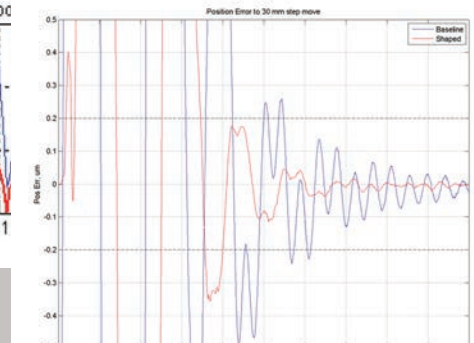

Command Shaping



- Sub-nanometer resolution
- AeroBasic™ programming language
- X65536 interpolation
- Analog and digital I/O

### Soloist



- Elegant, economical, single-axis controller
- Stand-alone
- Linear power stage
- Sub-nanometer resolution
- AeroBasic™ programming language
- X65536 interpolation
- Analog and digital I/O

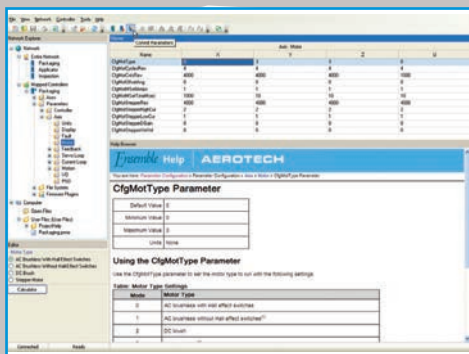
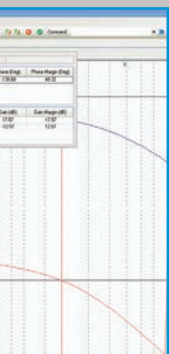

Parameter Editor

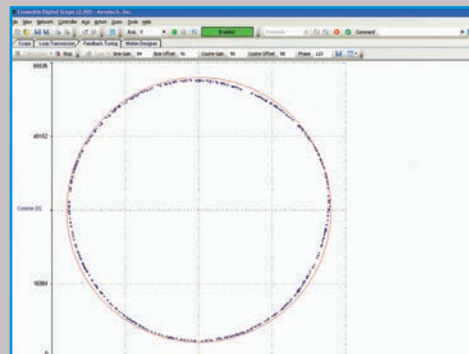

Encoder Tuning

# Nano Motion Control System Components

The ability to perform 1 nm moves requires a tightly integrated motion control system. The more stringent the specifications a system must meet, the more tightly the components must be integrated. While the challenge of achieving 1 nm steps with a complete Aerotech system is not trivial, the challenge of achieving 1 nm steps with a system made up of components from multiple suppliers is extremely difficult, if not impossible.

The following sections briefly describe these key components. Additional detail can be found in later pages.

## Controller Type

Aerotech offers three different controller families:

- Automation 3200 (A3200)
- Ensemble
- Soloist

Though the performance is identical between each of these products, each has unique features that are suitable to different applications.

## A3200

The A3200 controller is capable of synchronous motion for up to 32 axes. This PC based controller utilizes a distributed architecture to communicate with drives across a high-speed deterministic network. With all of the high-speed loop closure (position and current) done on the drives, performance does not degrade as axes are added.

## Ensemble

The Ensemble controller is capable of synchronous motion for up to 10 axes. This stand-alone controller utilizes a master node to coordinate the motion across the slave axes. Each of the slave axes connect to the master through a high-speed Aeronet bus to ensure synchronization across the axes. The PC is only required for initial setup.

## Soloist

The Soloist is a stand-alone, single-axis controller. For those applications that do not require synchronous motion, the Soloist is ideal. Like the Ensemble, the Soloist requires a PC only for initial setup. The tables that follow show a comparison between the three different controller families.

Basic Functions	A3200	Ensemble	Soloist
<b>Multi-Axis</b>	Up to 32 axes coordinated	Up to 10 axes coordinated	Single axis
<b>Architecture</b>	PC-based software controller	Stand-alone	Stand-alone
<b>Number of Tasks</b>	Up to 32	4	4
<b>CNC Functionality/RS-274</b>	◇		
<b>Coordinated Motion</b>	◇	◇	
<b>Point-to-Point Motion</b>	◇	◇	◇
<b>Cutter Compensation</b>	◇		
<b>Multi-Block Look-Ahead</b>	◇		
<b>Acceleration Limiting/Look-Ahead</b>	◇		
<b>Gantry Mode</b>	◇	◇	
<b>Velocity Blending</b>	◇	◇	◇
<b>Electronic Gearing</b>	◇	◇	◇
<b>Electronic Cam Profiling</b>	◇	◇	◇
<b>Arbitrary Path Generation</b>	◇	◇	◇
<b>Jog and Offset/Jog and Return</b>	◇		
<b>Velocity Profiling</b>	◇	◇	◇
<b>Retrace (Block by Block)</b>	◇		
<b>Axis Calibration</b>	◇	◇	◇
<b>3D Error Mapping</b>	◇		
<b>Sinusoidal Commutation</b>	◇	◇	◇
<b>Analog Power Control</b>	◇	◇	◇
<b>Servo, Stepper, or DC Motor Controller</b>	◇	◇	◇
<b>Expanded I/O Available</b>	◇	◇	◇
<b>Encoder Tuning</b>	◇	◇	◇
<b>Dual Loop Control</b>	◇	◇	◇

## Integrated Development Environment

Aerotech's Integrated Development Environment (IDE) is a suite of software tools that serves as the primary interface between the user and their system. Regardless of the controller chosen (A3200, Ensemble, or Soloist), the tools are the same. The IDE consists of the following elements:

- Motion Composer
- Configuration Manager
- Digital Scope
  - Servo Tuning
  - Loop Transmission
  - Dynamic Controls Toolbox
  - Encoder Tuning
  - Enhanced Throughput Module
- Motion Designer
- Diagnostics
- User Interface
- Dynamic Calibration Management System

Aerotech has spent over 40 years perfecting each of these tools to deliver the highest performing motion system. From the trajectory generator to our tuning screen, Aerotech's focus has been on pushing the technology and performance of its products. Each of these tools is covered in more detail on the following pages.

## 3rd Party Software

For those users wishing to integrate the controller products into their software module, Aerotech offers a variety of different interfaces to the most common development environments. These include:

- Microsoft .NET 2.0
- LabVIEW®
- EPICS
- C

## Power Electronics

The power electronics needed to perform these 1 nm steps require the use of high-performance linear amplifiers with low noise interpolation electronics. The power electronics are packaged as discrete amplifiers (ML Series), 19" rack mount (Npaq) or desktop unit (Epaq). The performance of each of these products is identical.

Advanced Functions	A3200	Ensemble	Soloist
<b>IDE</b>	◇	◇	◇
<b>.NET/AeroBasic™</b>	◇	◇	◇
<b>Fast Position Capture</b>	◇	◇	◇
<b>High-Speed Registration</b>	◇	◇	◇
<b>On the Fly End-Point Modification</b>	◇	◇	◇
<b>Orthogonality Correction</b>	◇	◇	◇
<b>Parts Rotation</b>	◇		
<b>Intra-Block Retrace</b>	◇		
<b>Iterative Learning Control</b>	◇	◇	◇
<b>PSO</b>	Yes; Up to 3 axes	Yes; Up to 3 axes	Yes
<b>Harmonic Cancellation</b>	◇	◇	◇
<b>Direction Gain Scheduling</b>	◇	◇	◇
<b>Inertial Damping</b>	◇	◇	◇
<b>Friction Compensation</b>	◇		
<b>Linear Drive Amplifiers</b>	◇	◇	◇
<b>Machine Retrofit Hardware Available</b>	◇		
<b>Galvo Integration</b>	◇		
<b>Seven-Segment Acceleration Profile</b>	◇	◇	◇
<b>Slice Move</b>	◇		
<b>Corner Rounding</b>	◇		
<b>Coordinate Transformations</b>	◇	With plug-in	
<b>Kinematics</b>	◇	With plug-in	
<b>Loop Transmission</b>	◇	◇	◇
<b>Advanced Diagnostics and Tuning</b>	◇	◇	◇
<b>Auto Focus</b>	◇		

# Motion Composer

## Development Environment for all Aerotech Controllers

Easy to use with extensive diagnostic tools, digital scope, and status utility

Shortens development time and includes multiple languages for development

Flexibility – use with any Aerotech controller: A3200, Ensemble, or Soloist

### Introduction

Aerotech's latest motion controller release focuses on ease of use for the programmer, shortens development times compared with other tools, and provides the flexibility to use the tools or controller most familiar to programmers. A complete Integrated Development Environment (IDE) and a comprehensive .NET motion library provide classes for motion, I/O, status, and diagnostic information. Program in Visual Studio and use the .NET library, or use the Motion Composer to develop code with English-style commands or G code. A LabVIEW® VI library is available for NI users, while a complete C library is available for those using VB6, C++, or C.

### Motion Composer Suite

The Motion Composer Suite includes the Motion Composer IDE, Digital Scope Configuration Manager, Console, Status Utility, and Firmware Loader. Optional modules include the CNC Operator's Interface, Motion Designer, Dynamic Controls Toolbox, and Enhanced Throughput Module. The Motion Composer Suite can be used with the Aerotech A3200, Ensemble, or Soloist controllers, and the features and benefits of each module are summarized below.

### Key Function of Each Module

The Motion Composer is an environment for developing and debugging AeroBasic programs for Aerotech controllers, and also functions as a simple operator's interface for the developer. The Motion Composer can be used to perform the following tasks:

- Write and debug programs – use breakpoint, step into, step over, colored programming, and standard program control (start, stop, pause, compile, etc.)
- Program flow control – If constructs, Looping constructs, Subroutines, Command basic motion
- Inspect diagnostic information
- Perform basic configuration

### Motion Composer

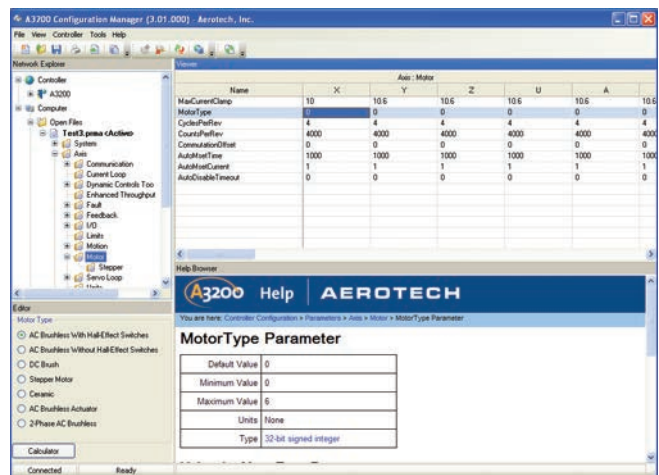
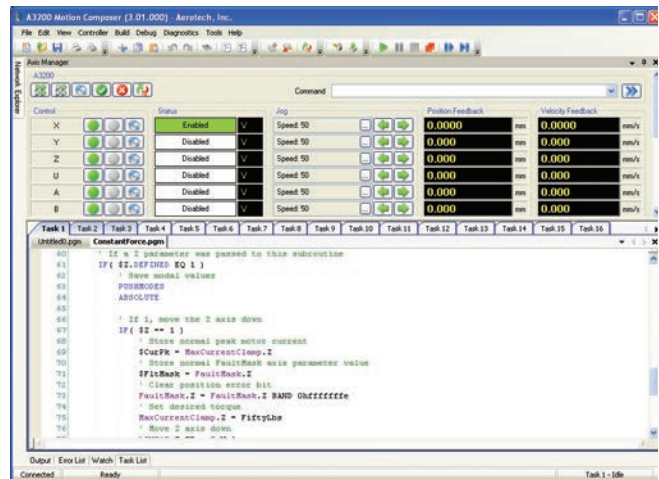

### Configuration Manager

Use the Configuration Manager to modify parameter files and set the active parameter file, as well as connection settings and program automation. All parameters are explained in the integrated Help File and presented in an organized tree structure. A variety of calculators are provided to make setup quick and easy.



## Motion Composer DESCRIPTION

Motion Composer Specifications	
<b>Standard Motion Composer Suite</b>	
Motion Composer	Develop and debug programs, jog axis, and view status
Configuration Manager	Edit parameters and change system settings
Digital Scope	Collect and analyze data
Console	Command line interface for low level hardware debugging
System Diagnostics	Debugging tool for status of drive signals, limits, inputs, halls, encoders, and more
Loader	Utility to update hardware/firmware
<b>Optional Motion Composer Modules</b>	
Motion Designer	Graphically generate motion profiles for execution on controller
CNC Operator Interface	Run programs, jog axis, view status and operate machine. Included in the CNC option (A3200 only)
<b>Optional Controller Modules</b>	
Dynamic Controls Toolbox	Control algorithms that increase system performance: settle time, accuracy, in-position stability, and/or velocity stability
Enhanced Throughput Module	Improves machine throughput by compensating for the effect of frame vibration on tooltip
Fiber Optic	Power band search used to align fiberoptic devices (A3200 only)
Nmark VCT and GRC	Provides integrated support for galvo laser system control (A3200 only)
CNC Option	Standard RS-274D or G and M code programming language (A3200 only)

### Digital Scope

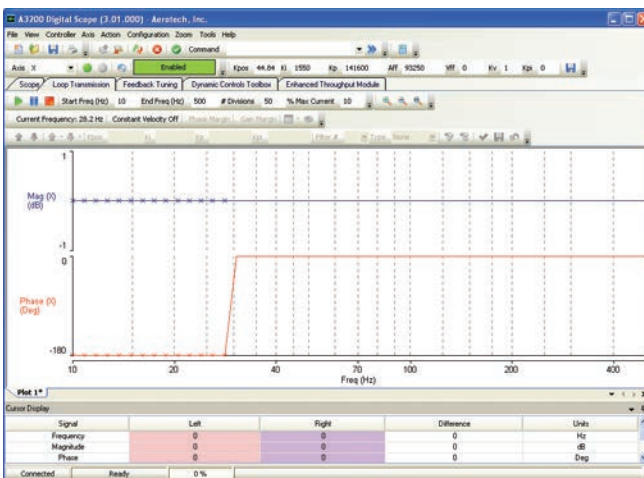
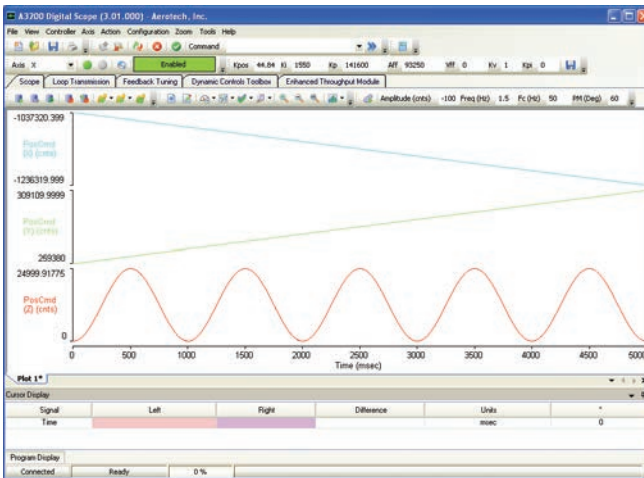

The Digital Scope is a system analysis and tuning application that allows the user to optimize system performance using a collection of advanced tuning tools and features. System analysis tools allow plotting and graphical analysis of system data, while tuning tools provide automatic calculation of servo loop and feedback device parameters.

The Digital Scope application includes a variety of utilities that allow the user to perform analysis and tuning operations including:

- Collecting and plotting various signals including position, velocity, and position error on multiple axes
- Viewing multiple overlapped one-dimensional and two-dimensional plots
- Graphically examining collected data using cursor and zooming tools
- Executing motion commands while collecting data
- Computing the discrete Fourier transform of any of the collected signals to identify system characteristics
- Automatically tuning the servo loop to achieve the desired system performance using the Autotune feature
- Calculating and enabling multiple digital filters to improve system performance
- Performing loop transmissions on each axis that allow advanced analysis and optimization of servo-loop tuning and performance
- Automatically tune an amplified sine encoder feedback device and view the results
- Conditional plotting to configure plots collected in the Digital Scope to display data differently based on input from the controller
- Data collected from an axis can be set to display as a

## Motion Composer Series DESCRIPTION

different color, or not display at all, based on the state of the controller's digital outputs and inputs. This is very useful when plotting tooltip trajectories during cutting or machining times.

- Data collected during run can be plotted and each line segment is linked to the program line generating the command. This makes increasing the throughput of the machine very easy on a line-by-line basis rather than just slowing down the entire process.

## Operator Interface

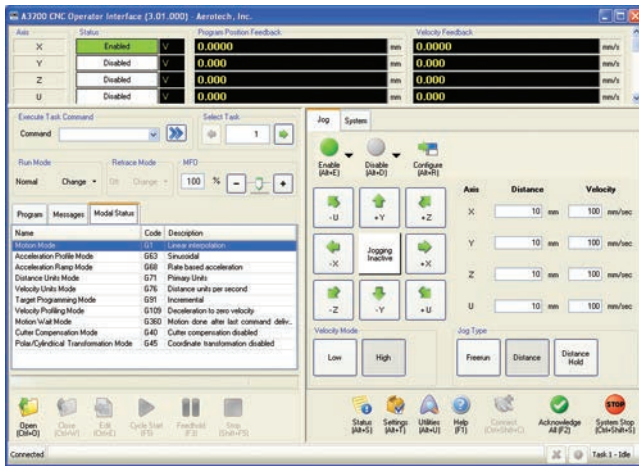

The Operator Interface provides a traditional CNC look and feel for operating a machine running G code. The interface provides a multi-axis readout with position, velocity shown in user units, immediate command, MFO, program scan during execution, modal status, and a multi-axis jog screen. Typical cycle start, stop, feedhold, and system stop buttons are included. The operator can open and load a new program, watch status, and manually control the machine. All buttons are designed for use with a touchscreen or a mouse.

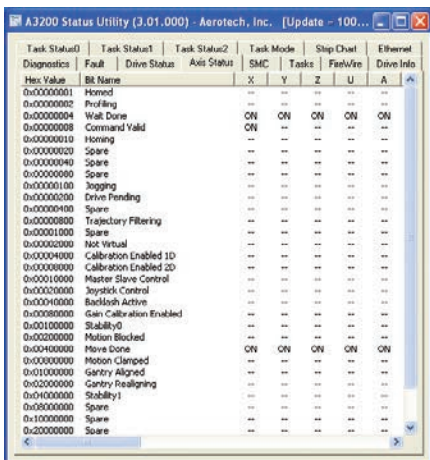

## Status Utility

The Status Utility is a debugging tool that graphically displays

the status of all 32 axes and all controller tasks. Use this for initial machine setup and testing. It displays the state of drive signals including the axes' hardware limits, drive enables, drive faults, probe input, Hall effect, and encoder feedback signals.

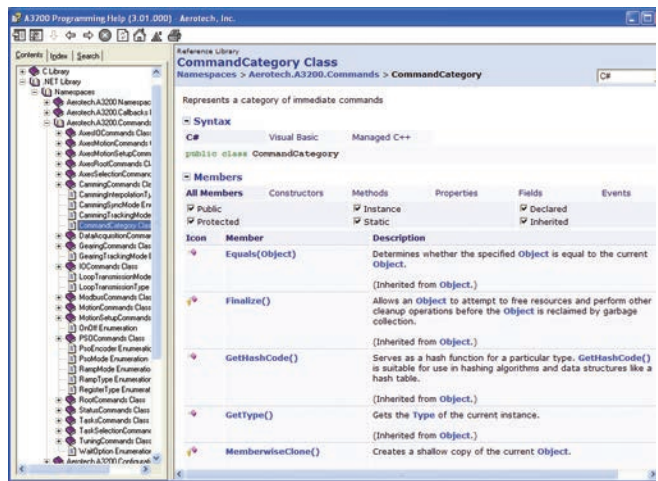

## Help Files

Help files are separated into the Motion Composer Suite programming Help file and the .NET and C library Help files. This limits the amount of unnecessary information to read when developing in one environment. Only licensed software modules are shown in the Help file to provide clarity for the user.



## Motion Composer Series DESCRIPTION

### Optional Motion Composer Modules – Dynamic Controls Toolbox

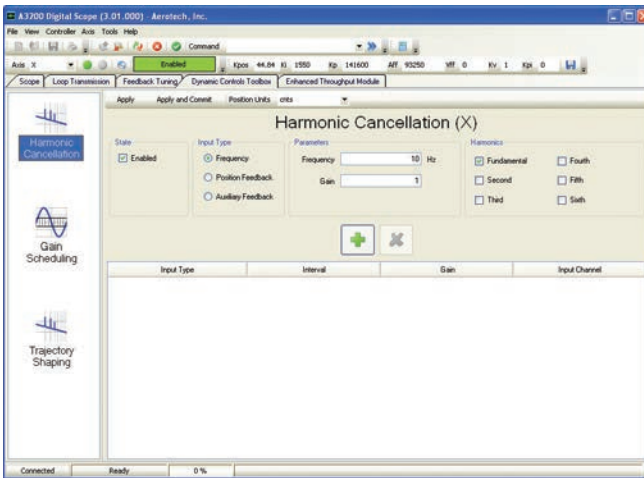

The Dynamic Controls Toolbox provides control algorithms that increase system performance such as settle time, accuracy, in-position stability, and/or velocity stability. These include Harmonic Cancellation, Threshold and Dynamic Gain Scheduling. Harmonic Cancellation includes a set of controller-level algorithms that are designed to improve performance by reducing the tracking error due to sinusoidal reference commands, motor force ripple (or other position-dependent disturbances), and cross-axis disturbances such as those created in a linear axis by an unbalanced rotational axis.

Threshold Gain Scheduling is a controller-level algorithm that adjusts the servo-loop gains based on a specific input: current or velocity either commanded or feedback. Two threshold zones are available.

The Dynamic Gain Scheduling algorithm can improve position performance and reduce cycle times. The algorithm changes the PID gains based on the servo error vector.

### Enhanced Throughput Module (ETM)

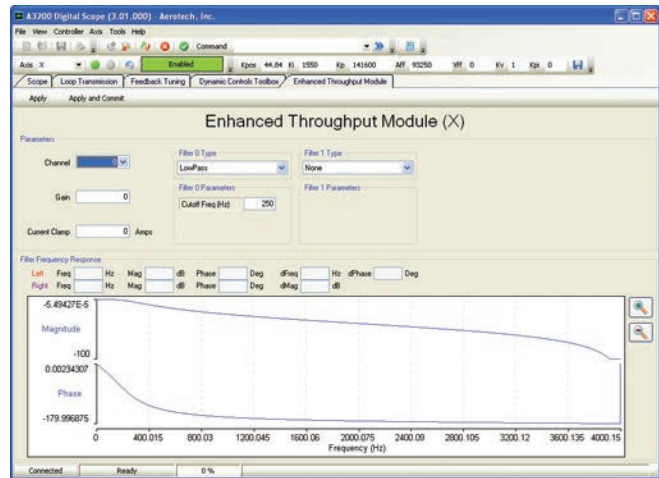

The ETM improves machine throughput by compensating for the effect of frame vibration on the tooltip. It provides for prefiltering input signals where necessary, and is available for single- or multi-axis operations.

.NET Library Classes	
AeroBasic Class	Compile AeroBasic programs and get build errors
Controller Class	Provides access to the different features of the controller and ability to configure the controller
Commands Class	Execute AeroBasic commands in .NET
Configuration Class	Configure A3200 system settings (for Ensemble and Soloist this is done using parameters)
DataCollection Class	Collect data on the controller in real time; Exposes functionality used by the Digital Scope
FileSystem Class	Control the file system on the Ensemble and Soloist controllers
Parameters Class	Access parameters on the controller and to handle data in parameter files
Status Class	Get status and monitor information coming from the controller
Tasks Class	Handle tasks and AeroBasic programs they are running

## Motion Composer Series DESCRIPTION

### Motion Designer



Motion Designer is used to graphically generate and edit motion profiles that execute on the controller, providing the ability to import, run, and evaluate motion profiles (trajectories). Motion Designer complements the Digital Scope tuning and data analysis application. Motion Designer features include:

- Importing an existing trajectory consisting of position, velocity, and/or acceleration state vectors from an external file
- Plotting trajectories and using analysis tools such as cursors and frequency domain estimation
- Creating and modifying trajectories using predefined building blocks
- Running a trajectory and plotting collected data
- Overlapping multiple runs of a trajectory
- Creating and exporting an AeroBasic program from an existing trajectory
- Reducing position error between runs by using learning algorithms
- Creating and running multi-axis trajectories

### Learning Control

Learning Control can be applied to the trajectory in Motion Designer to minimize the position error based on successive runs of the same move.

# ML Series

## Digital Servo Amplifiers – Linear

Output power range of 10 A peak with  $\pm 10$  to  $\pm 40$  VDC bus

DC input

CE approval

Linear power stages

Digital current, velocity, and position loops for improved motion stability

Integrated encoder multiplier for higher throughput and reduced wiring

Single- or multi-axis control

PC-based or stand-alone

The ML family of digital servo amplifiers is a collection of high performance discrete drives used with the Automation 3200, Ensemble, and Soloist motion controllers. Based on a common architecture, these amplifiers perform both current- and position-loop closures digitally.

The use of high-performance double-precision processors allows these drives to generate ultra-smooth motion profiles. Servo system response is optimized with the use of up to eight second-order loop-shaping filters, precise time-aligned feed-forward and other proprietary techniques with loop closure rates up to 20 kHz.

The ML family includes several versions of low noise,



From left to right: Ndrive ML, Ensemble ML, and Soloist ML.

ultra-high-performance linear drives. The ML drive provides high bandwidth and superb linearity required for the ultimate in velocity regulation as well as positional stability. It provides the highest level of encoder interpolation.

Options for the ML family include integral encoder interpolation, one- or two-axis position synchronized output (PSO), automatic brake control, digital and analog IO expansion.

## Ndrive ML/Ensemble ML/Soloist ML SPECIFICATIONS

ML Drives	Units	Ndrive ML	Ensemble ML	Soloist ML
Motor Style		Brush, Brushless, Stepper, Voice Coil	Brush, Brushless, Stepper, Voice Coil	Brush, Brushless, Stepper, Voice Coil
Motor Supply	VDC	±40 max	±40 max	±40 max
Control Supply <sup>(1)</sup>	VDC	18-36 VDC	18-36 VDC	18-36 VDC
Bus Voltage <sup>(2)</sup>	VDC	±40	±40	±40
Peak Output Current (1 sec) <sup>(3,4)</sup>	A <sub>pk</sub>	10	10	10
Continuous Output Current <sup>(3,4)</sup>	A <sub>pk</sub>	5	5	5
Digital Inputs	—	N/A	N/A	N/A
Digital Outputs	—	N/A	N/A	N/A
Analog Inputs	—	One 16-bit Differential; ±10 V	One 16-bit Differential; ±10 V	One 16-bit Differential; ±10 V
Analog Outputs	—	N/A	N/A	N/A
Dedicated Axis I/O on Feedback Connector		Three Limit Inputs (CW, CCW, Home); Three Hall Effect Inputs (A, B, C); Three High-Speed differential Inputs (sin, cos, mkr for encoder); Motor Over-Temperature Input	Three Limit Inputs (CW, CCW, Home); Three Hall Effect Inputs (A, B, C); Three High-Speed differential Inputs (sin, cos, mkr for encoder); Motor Over-Temperature Input	Three Limit Inputs (CW, CCW, Home); Three Hall Effect Inputs (A, B, C); Three High-Speed differential Inputs (sin, cos, mkr for encoder); Motor Over-Temperature Input
Dedicated I/O on Auxiliary Feedback Connector		sin, cos, mkr for Aux Enc; Aux Enc can be used for PSO Output	sin, cos, mkr for Aux Enc; Aux Enc can be used for PSO Output	sin, cos, mkr for Aux Enc; Aux Enc can be used for PSO Output
I/O Expansion Board <sup>(5)</sup>	—	8/8 Digital Opto-Isolated; 1 Analog In (±10 V, 16-bit Differential); 1 Analog Out (±5 V, 16-bit)	8/8 Digital Opto-Isolated; 1 Analog In (±10 V, 16-bit Differential); 1 Analog Out (±5 V, 16-bit)	8/8 Digital Opto-Isolated; 1 Analog In (±10 V, 16-bit Differential); 1 Analog Out (±5 V, 16-bit)
High Speed Data Capture		Yes (50 ns Latency)	Yes (50 ns Latency)	Yes (50 ns Latency)
Automatic Brake Control	—	Optional	Optional	Optional
Emergency Stop Sense Input (ESTOP) <sup>(6)</sup>	—	Standard; 24 V Opto-Isolated	Standard; 24 V Opto-Isolated	Standard; 24 V Opto-Isolated
Position Synchronized Output	—	Single Axis Only	Single Axis Only	Single Axis Only
Can Output Multiplied Encoder		Yes (MXH Only)	Yes (MXH Only)	Yes (MXH Only)
Can Output Square Wave Encoder		Yes	Yes	Yes
Primary Encoder Input Frequency		32 MHz Square Wave Standard; 2 MHz Sine Wave (MXU or MXH)	32 MHz Square Wave Standard; 2 MHz Sine Wave (MXU or MXH)	32 MHz Square Wave Standard; 2 MHz Sine Wave (MXU or MXH)
Secondary Encoder Input Frequency		32 MHz Square Wave	32 MHz Square Wave	32 MHz Square Wave
Encoder Multiplication	—	Up to x4096 (MXU); Up to x65536 with Quadrature Output (MXH)	Up to x4096 (MXU); Up to x65536 with Quadrature Output (MXH)	Up to x4096 (MXU); Up to x65536 with Quadrature Output (MXH)
Resolver Interface	—	N/A	N/A	N/A
Internal Shunt Resistor		N/A	N/A	N/A
External Shunt		N/A	N/A	N/A
Ethernet	—	N/A	N/A	N/A
USB		No	No	No
RS-232		No	No	No
FireWire		Yes	No	No
Fieldbus		Modbus TCP on PC	Modbus TCP; Ethernet/IP	Modbus TCP; Ethernet/IP
Current Loop Update Rate	kHz	20	20	20
Servo Loop Update Rate	kHz	8	8	8
Power Amplifier Bandwidth	kHz	Selectable Through Software	Selectable Through Software	Selectable Through Software
Minimum Load Inductance	mH	0	0	0
Operating Temperature	°C	0 to 50	0 to 50	0 to 50
Storage Temperature	°C	-30 to 85	-30 to 85	-30 to 85
Weight	kg (lb)	0.45 (1.0)	0.45 (1.0)	0.45 (1.0)

## Notes:

1. "Keep Alive" supply.
2. Output voltage is load dependent.
3. Peak value of the sine wave; rms current for AC motors is  $0.707 \cdot A_{pk}$ .
4. Load dependent.
5. Requires IO option.
6. Requires external relay to remove motor supply power.

## Ndrive ML/Ensemble ML/Soloist ML DIMENSIONS

ML with Optional IO  
(Dimensions without optional IO are identical)

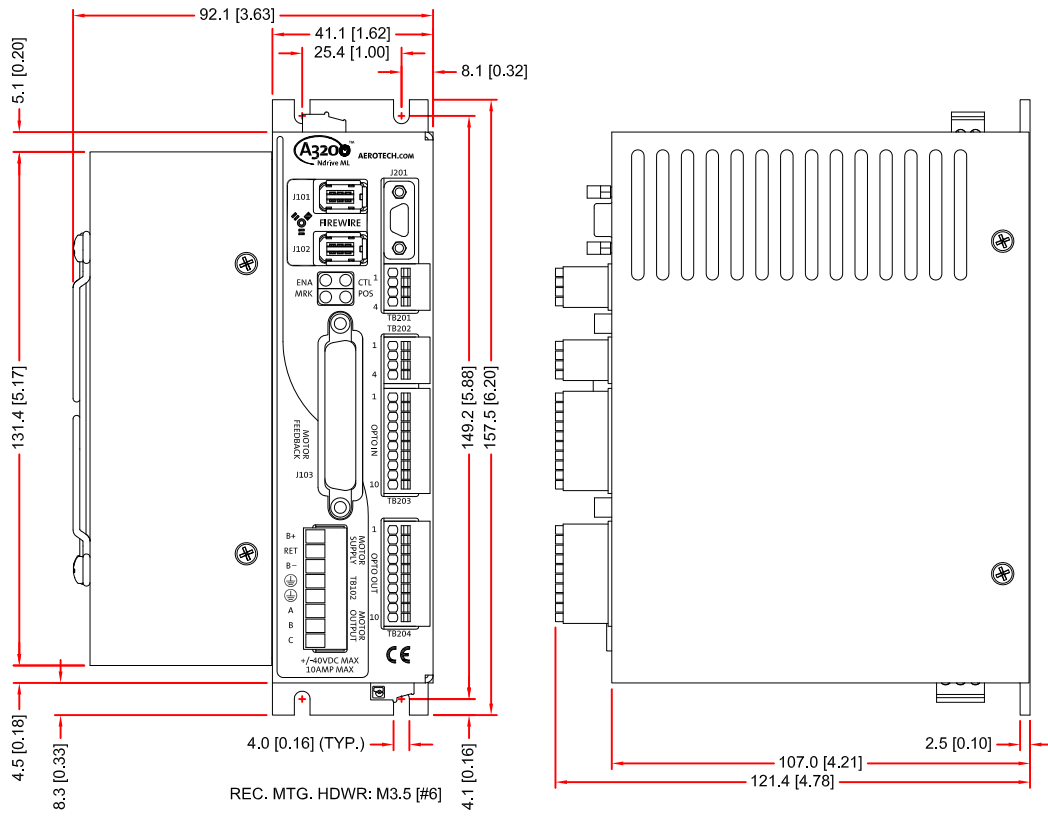

Ndrive ML, Ensemble ML, and Soloist ML share the same dimensions.

# Npaq Series

## Drive Racks for Nanometer Motion

- 3U plug-in drives or integral drives
- 19 inch rack-mount design
- Linear power stage
- Integral power supplies
- IEEE-1394 FireWire® interface
- Digital current, velocity and position loops for improved motion stability
- Optional Ethernet for I/O expansion
- UL and CE approval
- EN954-1 compliant
- Integrated encoder multiplier for higher throughput and reduced wiring

The Npaq is the high performance rack-mountable servo amplifier solution for the Automation 3200 motion system. The Npaq can control up to six axes of motion using a variety of plug-in amplifiers. The Npaq performs both current loop and servo-loop closure to ensure the highest level of positioning accuracy and rate stability.

The Npaq is built on a high-performance DSP that allows it to perform complex calculations in real time. It is this processing capability that allows the Npaq to provide loop closure rates up to 20 kHz, and to handle both digital and analog I/O, laser firing, and encoder multiplication.



*Npaq*



*Npaq MR*

Two independent supplies provide bus voltage to the amplifiers and may be configured to allow different bus voltages for different motors operating from the same Npaq. In order to provide the capability for increased I/O counts for PLC-type applications, the Npaq has an optional dedicated Ethernet port to communicate with I/O modules from third-party vendors.

Standard options for the Npaq include on-board encoder multiplication (up to x65536), three-axis position synchronized output (PSO), brake control logic, shunt regulator, external fan tray, and emergency stop relays.

## Npaq Series COMPONENTS

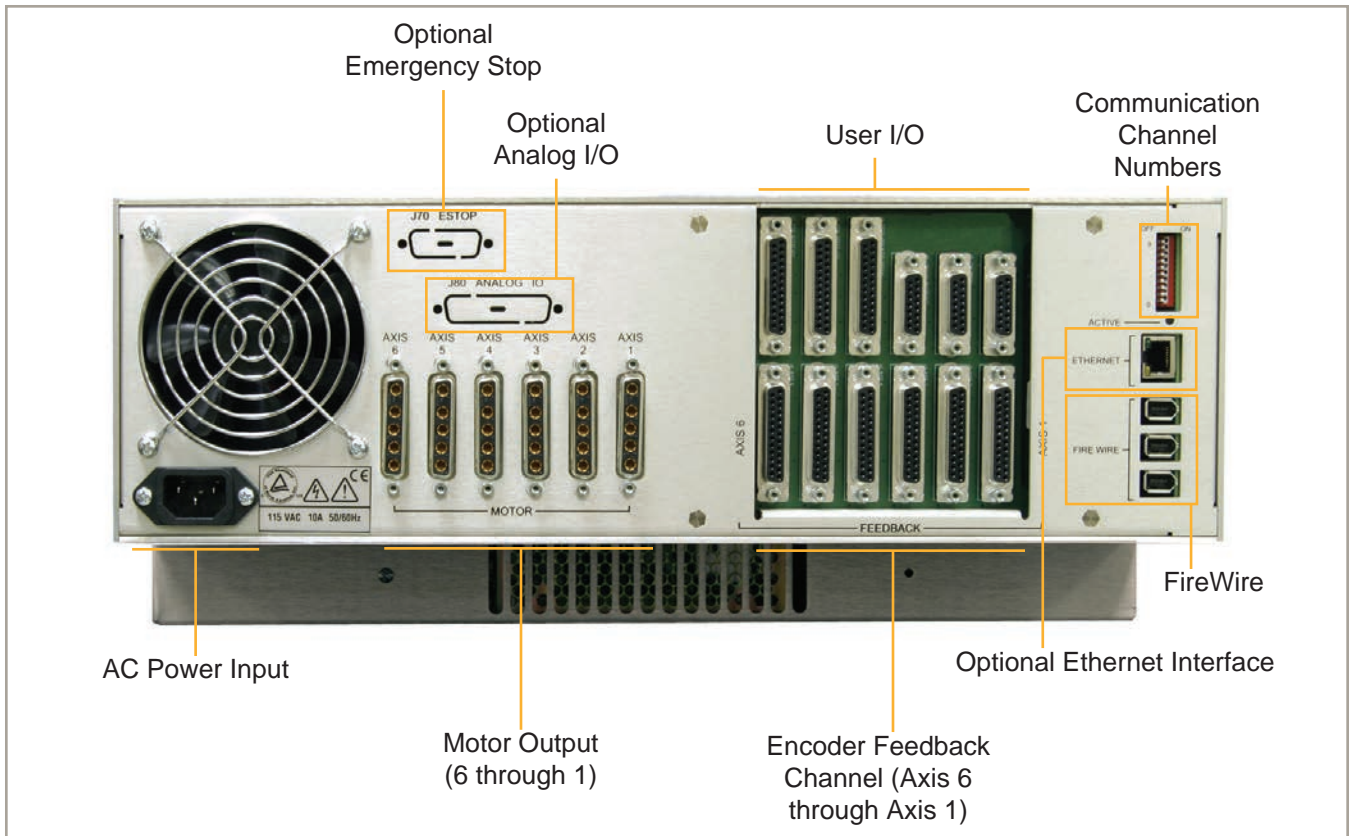

## Npaq Series PLUG-IN DRIVES



Amplifiers	DL4010
Control Type	Brushless, DC Brush, Stepper
Output Type	Linear
Output Voltage (VDC)	10-40 (Bipolar)
Continuous Current	5 <sup>(1)</sup>
Peak Current	10 <sup>(1)</sup>
Minimum Load <sup>(2)</sup>	0 ohms
Protection	Short Circuit Protection; Overload Protection; Low Level Power Supply Detection and Fuse
Switching Frequency	N/A

Notes:

1. Actual current ratings dependent on motor resistance

2. Minimum load is based on output voltage; 0.1 mH is minimum load at 160 VDC, 1.0 mH at 320 VDC



## Npaq Series SPECIFICATIONS

	Units	Npaq	Npaq MR
Number of Axes		1 to 6	1 to 8
Encoder Inputs		1 to 6; Additional Through High Speed Input	1 Primary and 1 Auxiliary Per Axis
Power Supply	VAC	Single-Phase 100-240 VAC; 50/60 Hz (Factory Configured)	
Bus Voltage	VDC	10-80	10-80
Peak Output Current (1 sec) <sup>(1)</sup>	A <sub>pk</sub>	10	10
Continuous Output Current <sup>(1)</sup>	A <sub>pk</sub>	5	5
Digital Inputs	—	Eight Optically-Isolated	Optional <sup>(2)</sup>
Digital Outputs	—	Eight Optically-Isolated	Optional <sup>(2)</sup>
Analog Inputs	—	Four 16-bit Differential; ±1 V to ±10 V	One 12-bit Differential Per Axis
Analog Outputs	—	Two 16-bit Single-Ended; ±10 V	Optional <sup>(2)</sup>
Dedicated Axis I/O on Feedback Connector		Three Limit Inputs (CW, CCW, Home); Three Hall Effect Inputs (A, B, C); Three High-Speed differential Inputs (sin, cos, mkr for encoder); Motor Over-Temperature Input	
Dedicated I/O on Auxiliary Feedback Connector		N/A	sin, cos, mkr for Aux Enc; mkr can be used for PSO Output
I/O Expansion Board <sup>(2)</sup>	—	Four Analog Input; Six Analog Output	One 12-bit Differential Analog Input; One 16-bit Analog Output; Eight Digital Outputs, Optically Isolated, Sinking or Sourcing; Eight Optically-Isolated Digital Outputs per Axis
High Speed Data Capture		Four Differential Inputs (1 μs Response Time)	Yes <sup>(4)</sup>
High Speed Digital Outputs		Six Differential Outputs	No
Bi-Directional Lines		3	No
Automatic Brake Control	—		Optional
Emergency Stop (ESTOP)	—		Optional
Position Synchronized Output (PSO)	—	Single Axis Standard, Two/Three Axis Optional	Single Axis Standard
Can Output Multiplied Encoder		Yes	Only With MXH Option
Can Output Square Wave Encoder			Yes
Primary Encoder Input Frequency with Multiplication		450 kHz or 2 MHz sine wave (MXH)	200 kHz sine wave (MXU); 450 kHz sine wave (MXH)
Primary Encoder Input Frequency – Square Wave		10 MHz square wave frequency/40 MHz count rate	
Secondary Encoder Input Frequency		10 MHz square wave frequency/40 MHz count rate	
Laser Feedback Support		Yes	No
Encoder Multiplication <sup>(3)</sup>	—	Up to x65536 With Quadrature Output (MXR)	x4096 (MXU); x65536 (MXH)
Internal Shunt Resistor		40 W Continuous; 400 W Peak (5 seconds)	No
External Shunt		Optional	No
Ethernet	—	Optional	No
USB			No
RS-232			No
FireWire			Yes
Fieldbus			Modbus TCP on PC
Joystick			Yes
Current Loop Update Rate	kHz		20
Servo Loop Update Rate	kHz	8	8
Power Amplifier Bandwidth	kHz	Selectable Through Software	
Operating Temperature	°C	0 to 50	
Storage Temperature	°C	-30 to 85	
Weight	kg (lb)	24 (55)	16 (35)

Notes:

1. Peak value of the sine wave; rms current for AC motors is  $0.707 * A_{pk}$ .
2. Requires IO option.
3. Effective resolution after quadrature decoding if applicable.



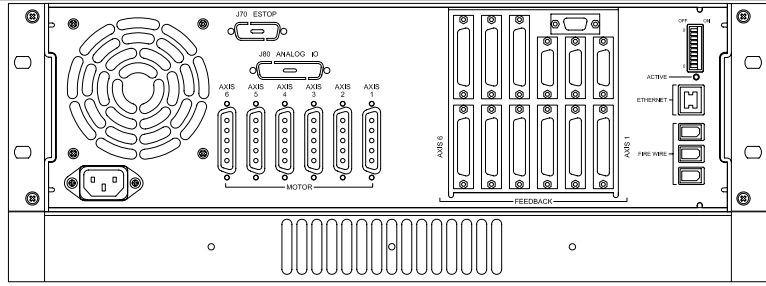

REAR VIEW ROTATED 180°

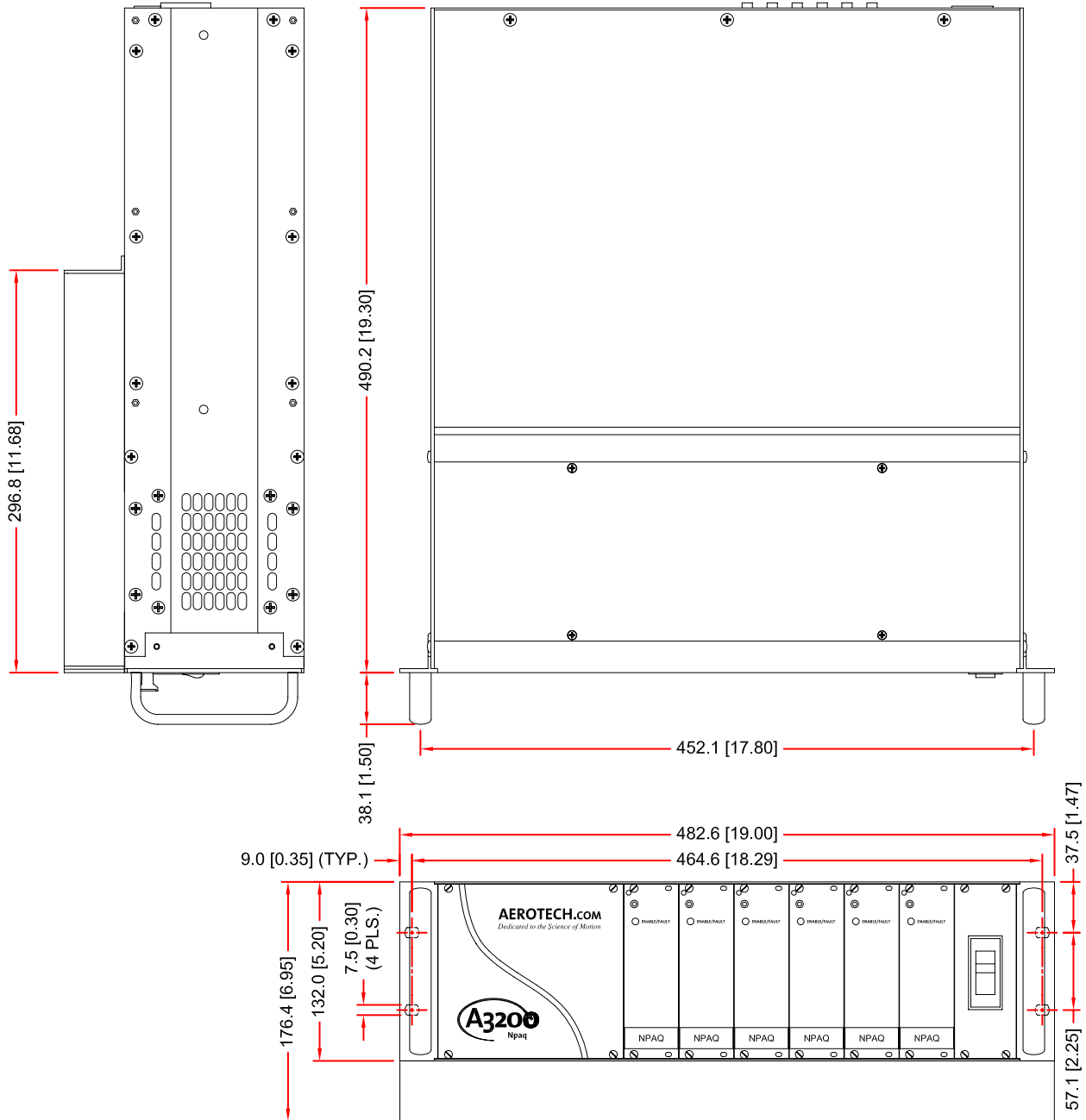

NPAQ WITH FAN TRAY OPTION

# Npaq MR Series DIMENSIONS

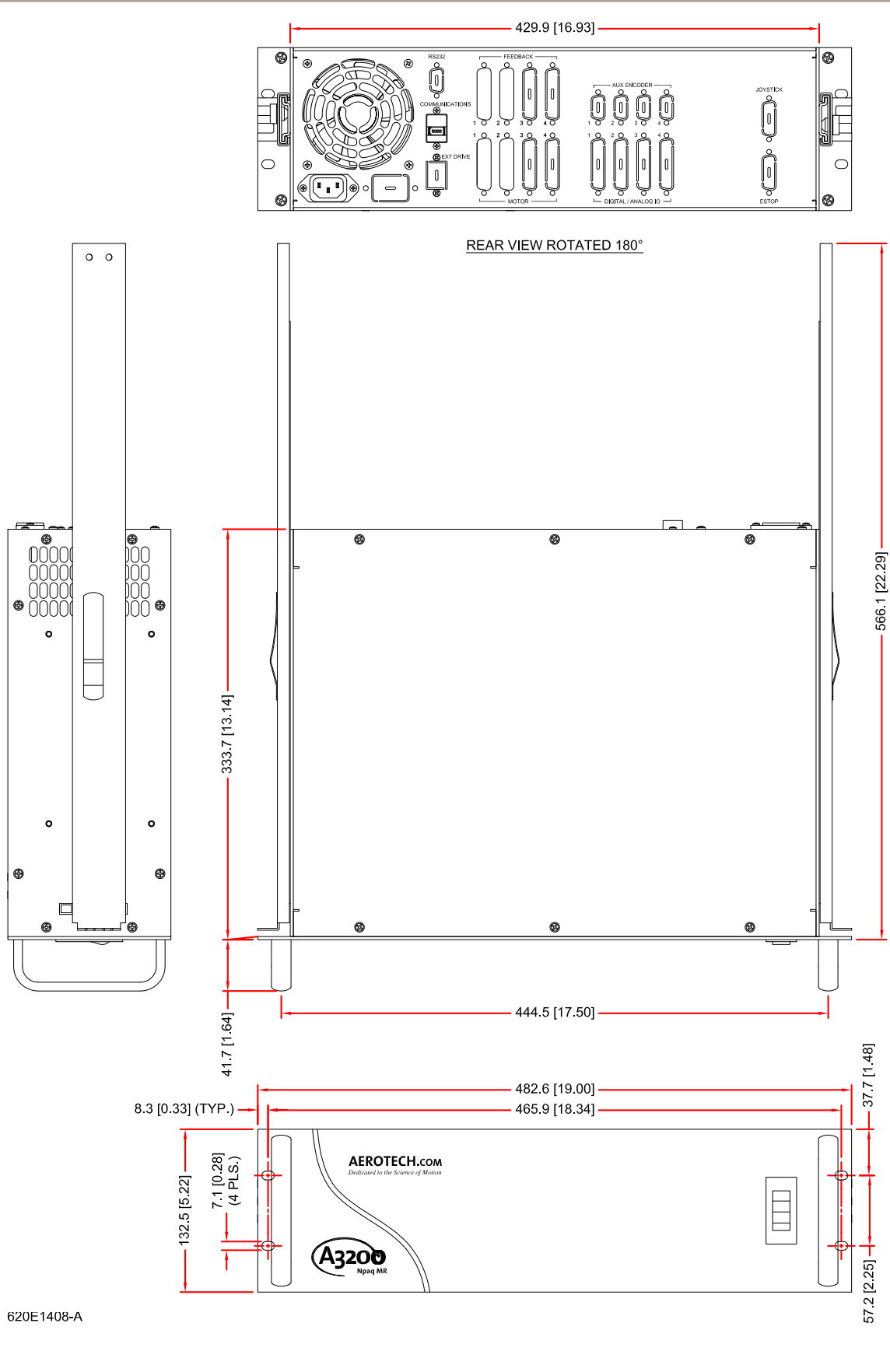

# Ensemble™ Epaq and Epaq MR Series

## Stand-Alone, Multi-Axis Motion Controllers for Nanometer Motion

Up to eight integrated drives in one stand-alone controller

Controller architecture capable of coordinating motion of up to five independent tasks

Complete motion capabilities include: point-to-point, linear and circular interpolation, electronic gearing, velocity profiling

Program in AeroBASIC™ with the IDE, Microsoft .NET including C#, VB.NET®, Managed C++, or LabVIEW®

Remote ASCII interface provided for Windows® or non-Windows® programs (including Linux) to command the Epaq through standard Ethernet, RS-232 port, and optional IEEE-488

Advanced Windows®-based remote diagnostics, tuning, and programming interface software

Front panel display and control pad for convenient menu-driven axis control and status checking

Axis jogging/control with optional joystick

Fully compatible with EPICS set of software tools and applications, making Ensemble ideal for use in synchrotron and general laboratory facilities

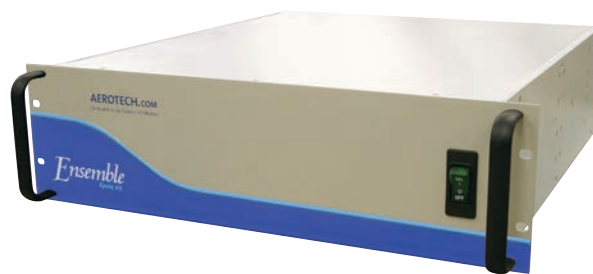

The Ensemble™ Epaq is Aerotech's next-generation, stand-alone controller for moderate- to high-performance applications. It offers functionality appropriate for applications from basic laboratory experimentation and general purpose positioning to advanced OEM systems at an affordable price.

### Versatile, Stand-Alone, Multi-Axis Control

The Ensemble Epaq is offered in three versions: a 6-axis desktop (rack-mount optional) version with display and jog pad, as well as 4- and 8-axis 3U rack-mount versions. All versions contain integrated power supplies and pluggable motor and IO connectors. Linear amplifiers are available for high performance, low noise applications. Higher power external amplifiers may be daisy-chained to the Epaq using the high-speed AeroNet serial interface for a total of nine axes of coordinated motion.

This flexible configuration style allows users to seamlessly mix and match drive types (linear versus PWM, brush or brushless, stepper, etc.) within the same positioning system using a common programming and control platform.

Multiple Epaqs can be controlled from one Windows® PC through Ethernet or USB. Optional on-board encoder interpolation offers the user programmable axis resolution

## Ensemble Epaq and Epaq MR DESCRIPTION

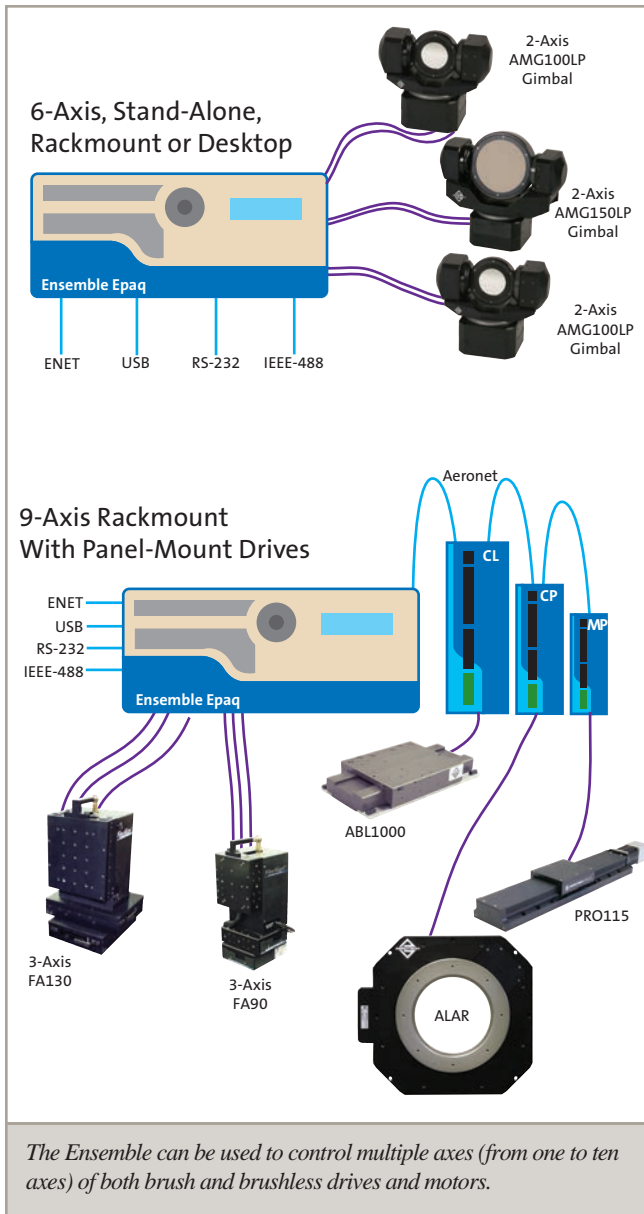

(assuming a sine-wave encoder input signal), including the ability to change interpolation (multiplication) values through software.

### Powerful and Intuitive Programming Functionality

Unlike most controllers on the market today, there is no need to understand a cryptic command set to generate motion. The intuitive interface allows a user to begin programming immediately. Ensemble online help further simplifies writing motion programs and includes many functional examples that can be easily modified for customer applications.

The Ensemble with Integrated Development Environment software offers a graphical user interface in Windows®, featuring an intuitive Program Editor, Variable Output window, Compiler Output window, and Task State monitor. This interface enables users to easily monitor all aspects of their positioning system, no matter how complex. The Axis Control and Diagnostic screens are further supplemented by a fully functional Autotuning utility that minimizes startup time and allows easy optimization of motion axes. System diagnostics are easily read from the interface. The Windows®-based remote software package is included with each unit, which allows the user to upload/download programs, modify parameter files, and analyze motion with Aerotech's advanced graphical tuning package, all from the convenience of a remote PC.

Whether operated in stand-alone mode through the front panel or by remote control through Ethernet or USB, the full functionality of the Ensemble Epaq is available. On-board configuration and monitoring utilities simplify remote communications. To allow easy serial connectivity and ease of use, the Epaq features an RS-232 port (additional RS-232 port is an option) and an optional IEEE-488 port.

### Advanced DSP Control

## Ensemble Epaq/Epaq MR Integrated Amplifier SPECIFICATIONS

Integrated Amplifier Electrical Specifications		ML
Output Voltage	VDC	10-40 V (Bipolar)
Peak Output Current	A	10 <sup>(1)</sup>
Continuous Output Current	A	5 <sup>(1)</sup>
PWM Switching Frequency	kHz	N/A
Power Amplifier Bandwidth	kHz	Software Selectable
Minimum Load Inductance	mH	0
Operating Temperature	°C	0 to 50
Storage Temperature	°C	-20 to 85
Weight	kg	0.5

Notes:

1. Actual current ratings dependent on motor resistance.

The Ensemble Epaq uses the processing power of multiple 225 MHz double precision, floating-point DSPs to offer exceptional performance in a variety of applications, including point-to-point motion, linear and circular interpolation, single- and multi-axis error correction, direct commutation of linear and rotary brushless servomotors, and on-board servo autotuning. High-speed interrupts and data logging capabilities provide a real-time link to external systems. The Ensemble Epaq also offers high-speed position latching capability and optional single-axis PSO (Position Synchronized Output). Whether the requirement is simple point-to-point motion or complex velocity profiled contours with output on the fly, Ensemble ensures peak performance for critical applications.

### Integral Drives

The Epaq can control any combination of up to six integral drives, while the Ensemble architecture is capable of further expansion (with external stand-alone, single-axis drive units) to up to nine total axes. Because the Epaq can control many different types of motors, customers have excellent flexibility in their system designs. High accuracy, linear-motor-driven air-bearing stages can be controlled from the same controller running lower precision drives with servo or stepper motors. Parameters are easily reconfigured for these various motors and feedback devices, so customers can adapt to changing system needs.

### Expanded Input/Output Capability

Each Epaq features an optional IEEE-488 parallel port, second RS-232 port, and axis expansion port. On a per axis basis the Epaq also features an optional I/O package offering eight digital inputs and outputs, one 12-bit  $\pm 10$  VDC analog input, one 16-bit  $\pm 5$  VDC output, a configurable brake output, a second TTL encoder input for dual loop control, and either a second marker input or PSO output. This optional I/O package can be added to each axis so numerous I/O can be connected to the Epaq.

### Enhancing a Legacy of Success

Although Ensemble is envisioned as a general-purpose, stand-alone controller, it carries forward a legacy of success built from Aerotech's A3200 and Soloist™ controllers. It offers enhanced capabilities that make it an ideal choice for many aggressive motion control applications. The Ensemble motion control architecture builds upon the Soloist's intuitive graphical user interface, while offering advanced features appropriate for multi-axis control. Ease of use is further improved with pre-coded LabVIEW® VIs, AeroBASIC™ programming functionality, .NET tools for C#, VB.NET, and managed C++.

### EPICS Drivers

EPICS is used worldwide at leading light source (synchrotron) facilities and other government laboratories. Each Ensemble installation includes full compatibility with the EPICS open source distributed control system, allowing Ensemble to seamlessly integrate into applications at all major research institutions.

## Ensemble Epaq and Epaq MR SPECIFICATIONS

	Units	Epaq	Epaq MR
Number of Axes		1 to 6	1 to 8
Encoder Inputs		1 to 6	1 Primary and 1 Auxiliary Per Axis
Power Supply	VAC	100-240 VAC; 50/60 Hz (Factory Configured)	
Bus Voltage	VDC	10-80	
Peak Output Current (1 sec) <sup>(1)</sup>	A <sub>pk</sub>	10	
Continuous Output Current <sup>(1)</sup>	A <sub>pk</sub>	5	
Digital Inputs	—	No	
Digital Outputs	—	No	
Analog Inputs	—	One 16-bit Analog Input per Axis	
Analog Outputs	—	No	
Dedicated Axis I/O on Feedback Connector		Three Limit Inputs (CW, CCW, Home); Three Hall Effect Inputs (A, B, C); Three High-Speed differential Inputs (sin, cos, mkr for encoder); Motor Over-Temperature Input; One 16-bit Analog Input	
Dedicated I/O on Auxiliary Feedback Connector		sin, cos, mkr for Aux Enc; Aux Enc can be used for PSO Output	
I/O Expansion Board <sup>(2)</sup>	—	One 12-bit Differential Analog Input; One 16-bit Analog Output; Eight Digital Outputs, Optically Isolated, Sinking or Sourcing; Eight Optically-Isolated Digital Outputs per Axis	
High Speed Data Capture		Yes <sup>(2)</sup>	
High Speed Digital Outputs		No	
Bi-Directional Lines		No	
Automatic Brake Control	—	Optional	
Emergency Stop (ESTOP)	—	Optional	
Position Synchronized Output (PSO)	—	Single Axis Standard	
Can Output Multiplied Encoder		Yes (only with MXH option)	
Can Output Square Wave Encoder		Yes	
Primary Encoder Input Frequency with Multiplication		200 kHz (MXU) or 450 kHz (MXH) sine wave	
Primary Encoder Input Frequency – Square Wave		10 MHz square wave frequency/40 MHz count rate	
Secondary Encoder Input Frequency		10 MHz square wave frequency/40 MHz count rate	
Laser Feedback Support		No	
Encoder Multiplication <sup>(3)</sup>	—	x4096 (MXU); x65536 (MXH)	
Resolver Interface	—	No	
Internal Shunt Resistor		No	
External Shunt		No	
Ethernet	—	Yes	
USB		Yes	
RS-232		Yes	
FireWire		No	
Fieldbus		Modbus TCP on PC	
Joystick		Yes	
Additional Interfaces		10/100 Base T Ethernet communication interface for system setup, application networking, Epaq-to-Epaq communications, embedded programming, immediate commands, and Modbus over TCP; USB communication interface for system setup, application networking, Windows® PC control interface; RS-232 port with programmable baud rate, length, parity, stop bits (second RS-232 port optional)	
		ESTOP to Stop All Axes	No
		Display: Backlit 8 x 40 Character LCD	No
		Keypad: 5-Key Input Pad	No
Other I/O		One Optional GPIB (IEEE-488)	No
Current Loop Update Rate	kHz	20	
Servo Loop Update Rate	kHz	1 to 20	1 to 20
Power Amplifier Bandwidth	kHz	Selectable Through Software	
Operating Temperature	°C	0 to 50	
Storage Temperature	°C	-30 to 85	
Weight	kg (lb)	10 (22)	16 (35)

Notes:

1. Peak value of the sine wave; rms current for AC motors is  $0.707 * A_{pk}$ .
2. Requires I/O option.
3. Effective multiplication factor after quadrature decoding (if applicable).

# Ensemble Epaq DIMENSIONS

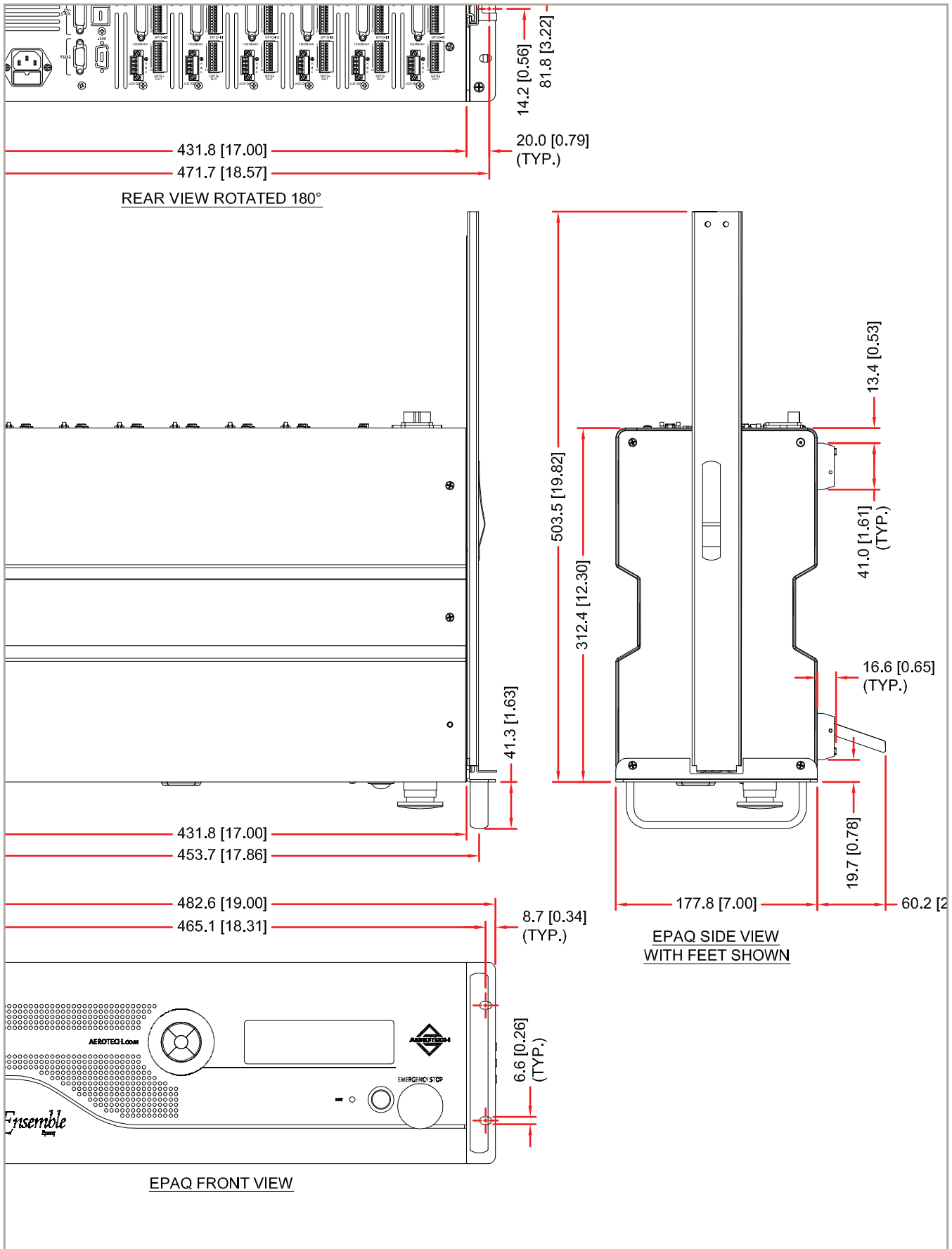

# Ensemble Epaq MR DIMENSIONS

## 4-Axis Chassis

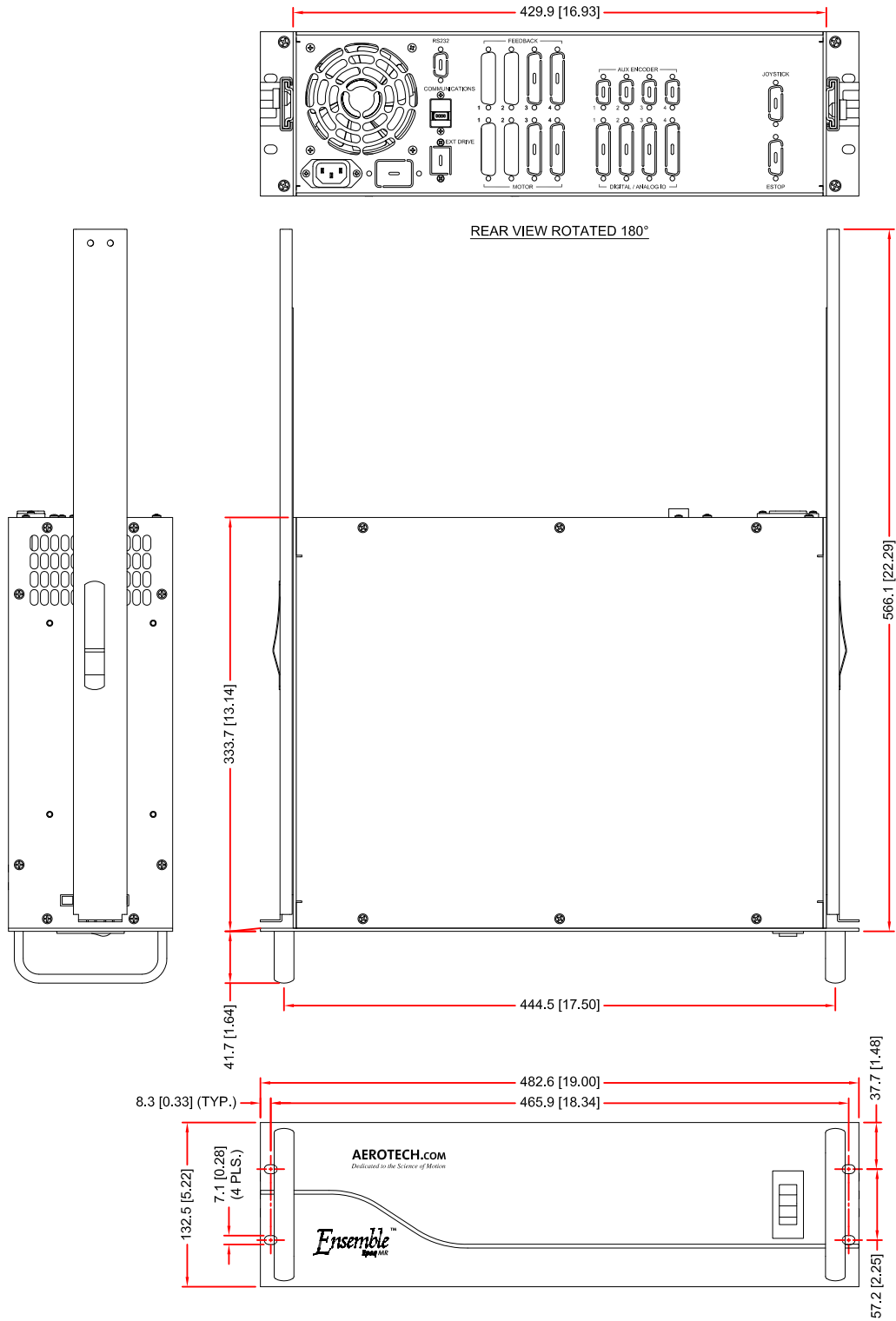



8-Axis Chassis

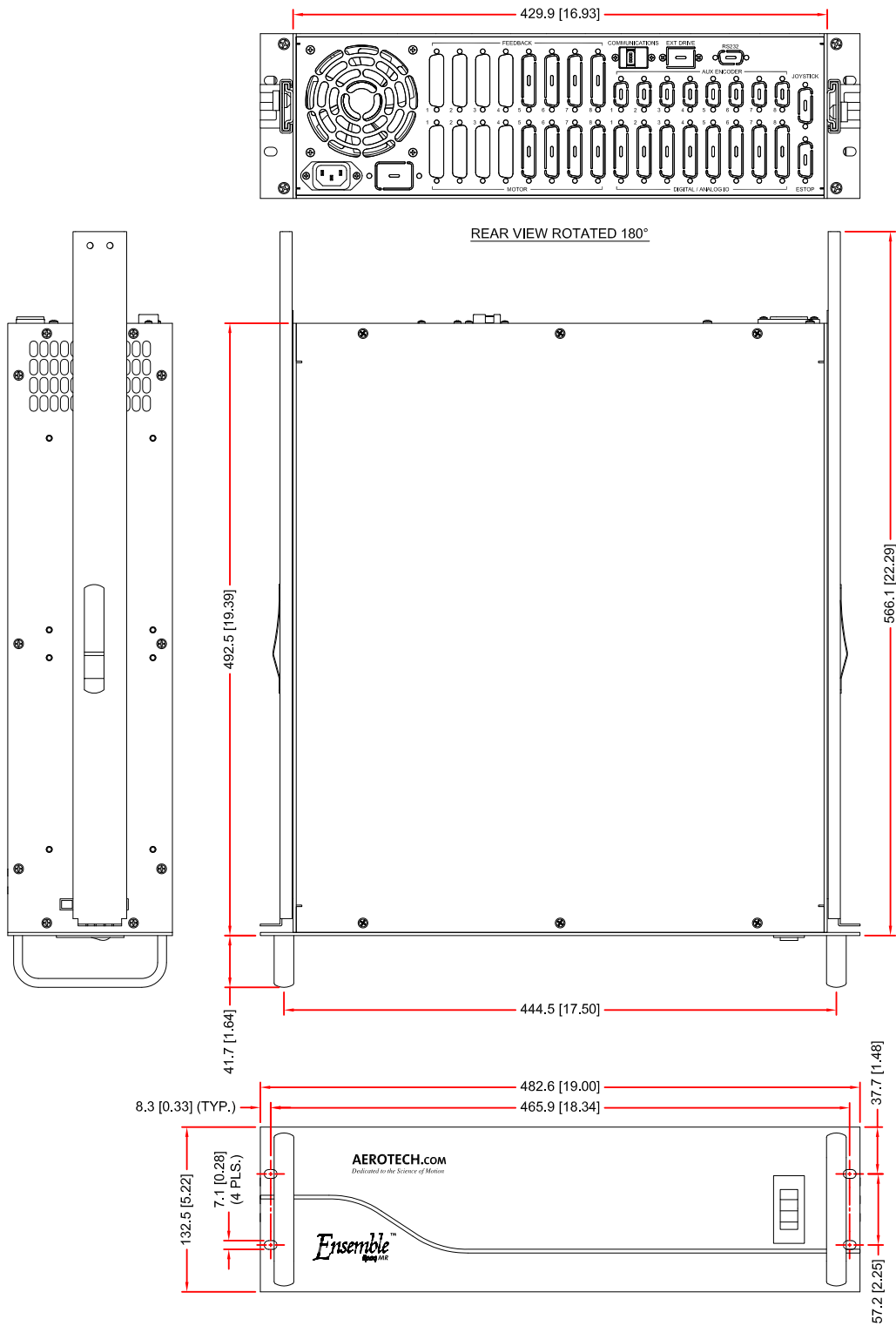

# Aerotech at a Glance



Corporate Headquarters • Pittsburgh, PA • USA



Aerotech UK



Aerotech Germany



Aerotech Japan



Aerotech China

## High Volume Manufacturing



Over 100,000 axes installed worldwide

## Worldwide Service and Support



Worldwide startup service and on-site training

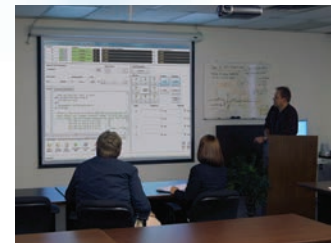

Fully equipped on-site training facilities

## Technically Superior Components

Highest performance brushless linear and rotary motors

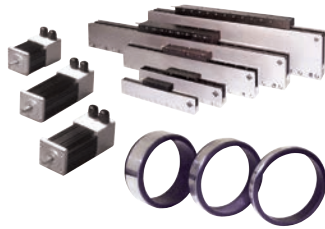

AGR rotary stage

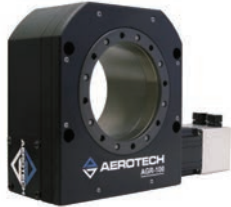

PRO series linear motor stage



Ndrive®

A3200



Npaq®

Award-winning Automation 3200 1-32 axis motion, vision, PLC, robotics, and I/O platform

## High Performance Sub-Assemblies



XYAB subsystem for high dynamic accuracy positioning in laser drilling and micromachining applications

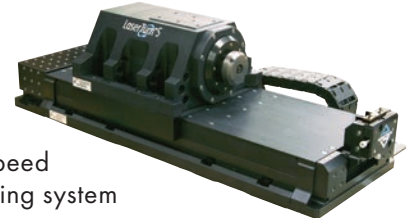

LaserTurn® 5 high-speed cylindrical laser cutting system

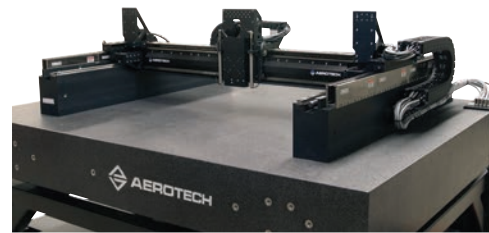

Highest throughput linear motor Cartesian gantry systems

## Best-in-Class Subsystems

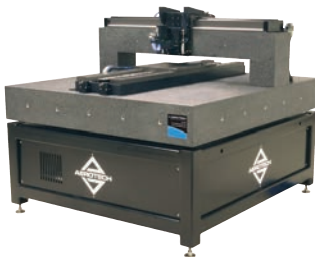

Highly integrated motion subsystems with machine frame, display, and packaged electronics

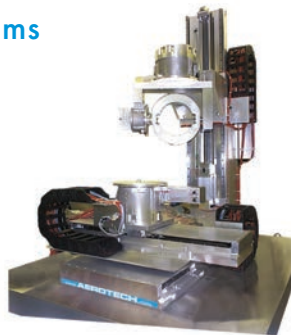

Custom-engineered vacuum- and cleanroom-compatible systems



Production-proven, large format air-bearing systems for flat panel and semiconductor applications

## Comprehensive Technical Support Services



Custom software application support

3D models to facilitate faster and more accurate system layout

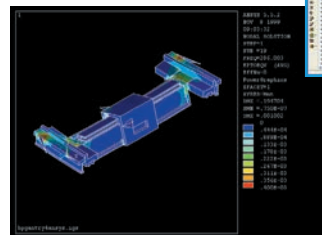
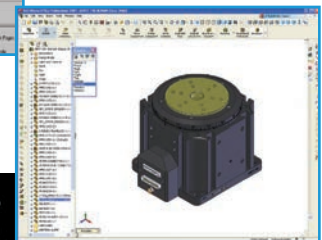

Advanced analytical techniques for optimization of system geometry



# Custom Systems

Aerotech designs and manufactures specialty high-performance subsystems. Our highly-trained staff of experienced software and hardware engineers enables our customers to get to production readiness faster. Aerotech provides real-time collaborative support — either at your facility, at our facility, or on the web.

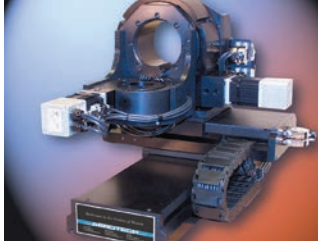

*Advanced Laser Machining*

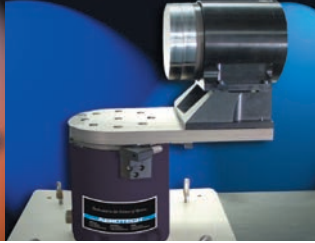

*Two-Axis Part Positioner*

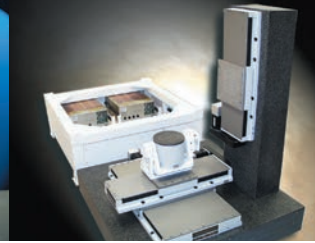

*Rapid Prototyping*



*Advanced Pick-Place-Inspect Station*



*Ion Beam Profiling in Vacuum*



*Precision Optical Production*

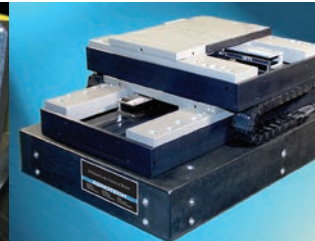

*High-Precision Air Bearings*

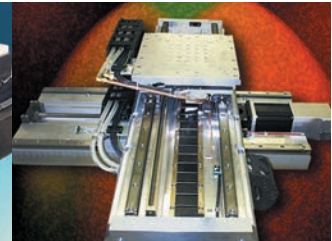

*Liquid-Cooled, Vacuum-Prepped System*



*High Volume Production Inspection Station*



*4-Axis Coordinate Measuring Machine*



*Electronic Inspection*

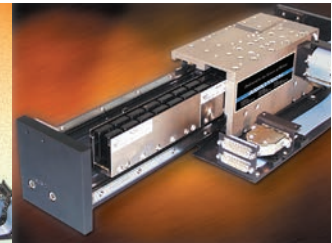

*High-Speed Optical Indexer*

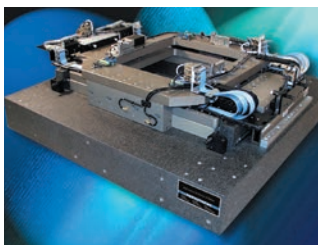

*Patterned Media Inspection*



*Printhead Inspection Station*



*High-Accuracy Laser Machining*



*Optical Lens Fabricating*

# Awards and Recognition



Design News 2010 Golden Mousetrap Winner – ANT-130XY



Design News 2009 Golden Mousetrap Finalist Product – LaserTurn® 1, AGS15000, ANT95-XY



2008 Control Engineering Engineers' Choice Award – LaserTurn® 1



Semiconductor International 2008 Editors' Choice Best Product – Ensemble™



Design News 2008 Golden Mousetrap Finalist Product – Nmark™ SSaM



Semiconductor International 2007 Editors' Choice Best Product – WaferMax T™



EuroAsia IC 2006 Industry Award – WaferMax Z™



2002 Finalist

Product Design and Development 2002 Top 50 Product – Automation 3200



Design News 2002 Best Product Nominee – Automation 3200



Aandrijftechniek 2002 Award – FiberMax®



Lightwave NFOEC 2002 Attendees' Choice Award – FiberMax®



Lightwave OFC 2001 Attendees' Choice Award – FiberAlign® 130



Machine Design Excellence in Manufacturing Technology – Slides/Ways 1998 and 2000



# Capabilities in Other Markets



## Photovoltaic, Fuel Cell, and Alternative Energy

Extensive application experience and a broad array of motion products make Aerotech the perfect partner for your photovoltaic (solar cell), fuel cell, and other alternative energy manufacturing and testing platforms. Our worldwide operation has engineered and manufactured a multitude of motion platforms for these markets and we continue to provide innovative solutions.

## General Automation

Since 1970 Aerotech has been a manufacturer of top-quality automation products. The breadth of the company's product line, including automated nanopositioners, planar air-bearing systems, high-speed gantries, linear and rotary and lift stages, brushless linear and rotary servomotors and drives, single- and multi-axis motion controllers, goniometers, and gimbals/optical mounts, makes Aerotech unique among motion control manufacturers. Aerotech is Dedicated to the Science of Motion.



## Control Systems

Aerotech motion controllers, motors, and drives are utilized in our own positioning systems and by end users and OEMs worldwide. From our Automation 3200 software-based motion controller that can control up to 32 axes, to the Soloist™ single-axis servo controller, to the Ensemble™ multi-axis stand-alone motion controller, Aerotech provides a variety of options to suit your application.

## Laser Processing

Aerotech has extensive experience in providing motion components and subsystems for laser processes such as cutting, welding, marking, etching, and micromachining. These processes are the key to advancing technology in markets such as photovoltaic manufacturing, aerospace and medical device manufacturing.

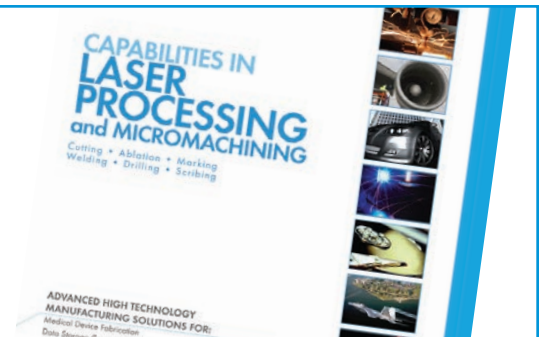

## Medical Device Manufacturing and Life Sciences

Aerotech manufactures high-performance motion systems and components for medical and life sciences applications including stent cutting, medical laser welding systems for cardiac pacemakers and catheters, IOL and contact lens manufacturing, DNA sequencing, blood sequencing, haptic mills and drills, x-ray machines, magnetic resonance scanners, and CAT scanners. We can customize a medical laser welding system for any need.

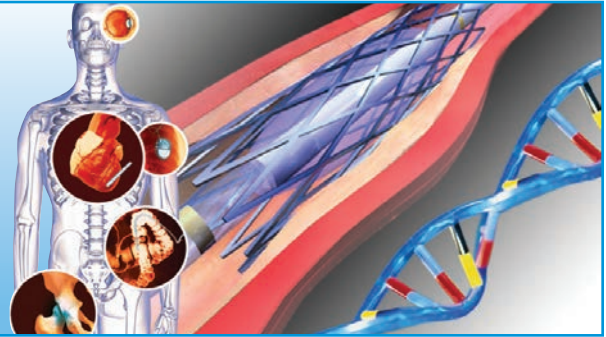

## AEROTECH Resource Guide

of  
Motion and Positioning Control  
Components

Resource Guide  
of Motion and Positioning Control  
Components and Systems

Gantries  
Linear Stages  
Linear Actuators  
Rotary Stages

AEROTECH, Inc.  
10000 Aerotech Drive  
Chandler, AZ 85226  
Tel: 480.754.1000  
Fax: 480.754.1001  
www.aerotech.com

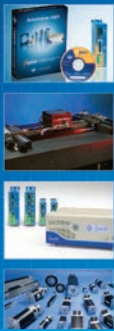

## Government and Educational Research and Development

The breadth of Aerotech's product line offers solutions for the wide-ranging requirements of academic and government R&D. The fiberoptic line of positioning stages provides the accuracy required not only for photonics experiments, but also for micro- and nano-machining workstations. Aerotech's multi-axis rotary positioners and gimbals offer the high precision needed for defense, satellite, and space science research. Unique applications call for unique solutions, and Aerotech can provide custom-engineered systems to meet your needs.

## Electronics Manufacturing and Assembly

Speed, accuracy, and reliability are the key requirements for pick-and-place machines, stencil cutting machines, printed circuit board assembly, and other electronic manufacturing and assembly equipment. Since 1970 Aerotech has exceeded the most stringent criteria used to judge electronic manufacturing and assembly equipment, and we continue to raise the standard with our advanced motion technologies by addressing industry-specific challenges in pick-and-place machines, stencil cutting machines, and printed circuit board assembly systems.



## Test and Inspection

Aerotech is involved in test and inspection across a wide array of industries with applications including CMMs, ultrasonic, eddy current, x-ray, optical, and electronic. All of these applications rely on Aerotech products' unmatched precision, accuracy, and durability. Optical inspection solutions range from high-end linear-motor-driven models packaged with all control elements in an optimized machine base, to modular systems specifically designed for cost-sensitive applications.

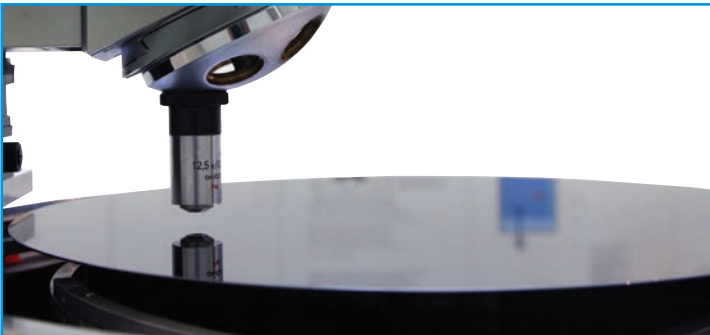

# Aerotech Online

Aerotech's website at [www.aerotech.com](http://www.aerotech.com) is your comprehensive resource for all Aerotech information worldwide. Complete information is provided for all products including specifications and downloadable 2D and 3D models. Register for our e-newsletter In Motion to receive news on all of the current activities at Aerotech.

## Product Navigation

Easy-to-use product navigation intuitively and quickly guides you through our broad product range.

## Select your Market

Our *Select a Market* feature details market-specific automation solutions.

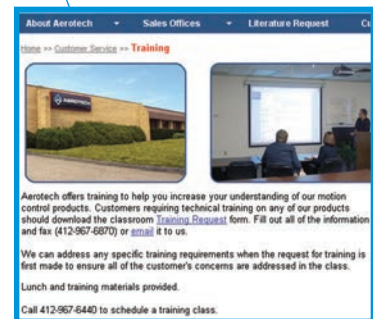
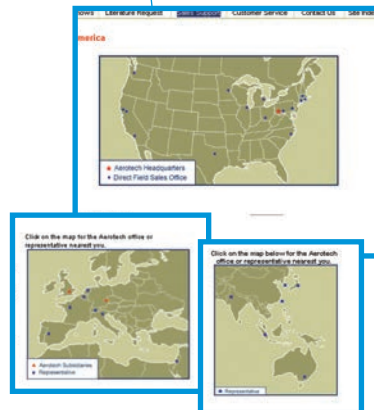

## Current Product and Company News

The most current product and company news is featured prominently on our homepage.

## Worldwide Sales Office Locator

Use our worldwide sales office locator to quickly find an Aerotech office near you.

## Customer Service

Our customer service center provides contact information for Aerotech Customer Service worldwide. Also included are details on our training programs, software and product manual downloads, and an FAQ section.



# Worldwide Training and Support

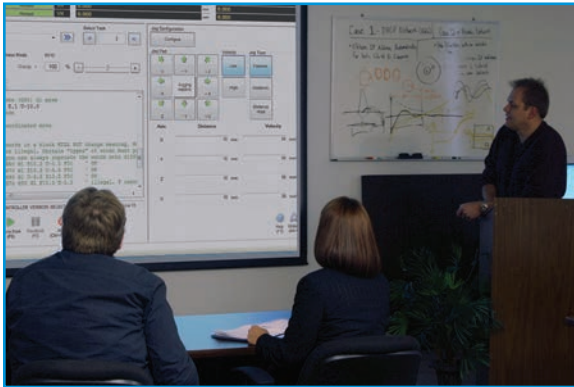

Aerotech Inc (U.S.A.)



Aerotech Ltd (United Kingdom)



Aerotech GmbH (Germany)



Aerotech KK (Japan)

Aerotech offers comprehensive worldwide training and customer service either at customer facilities or at one of our Aerotech training centers.

## Our Training Program Features:

- Standard and customized courses
- Hands-on training with Aerotech positioning systems
- Interactive training with experienced instructors
- Comfortable, spacious facilities

## Installation and Start up (Commissioning)

Aerotech offers startup and commissioning services to minimize startup times, reduce cost and accelerate time-to-production. By combining our product knowledge with your process and application expertise, new systems and applications can be completed faster at a reduced overall cost.

## Engineering Support

Aerotech provides complete engineering support for our products, including onsite support and maintenance, and remote support via phone, fax, website, and/or WebEx® software. As a manufacturer staffed by engineers, we understand the unacceptability of downtime.

## Training

Aerotech training classes are designed to help our customers realize the full potential of our products. By demonstrating all of a product's features and how to use them, customers have been able to reduce startup time and quickly optimize their applications. Aerotech's classes have been developed, and continually upgraded, using feedback from our customers.

Since 1970, Aerotech has designed motion control and positioning systems and components with an unsurpassed track record of reliability. When you make the choice to purchase from Aerotech, we urge you to learn how to get the most from your new Aerotech products. Aerotech provides both on-site (your facility) and/or in-house (our facility) training for our customers' convenience.

## Aerotech's Worldwide Sales and Service Locations

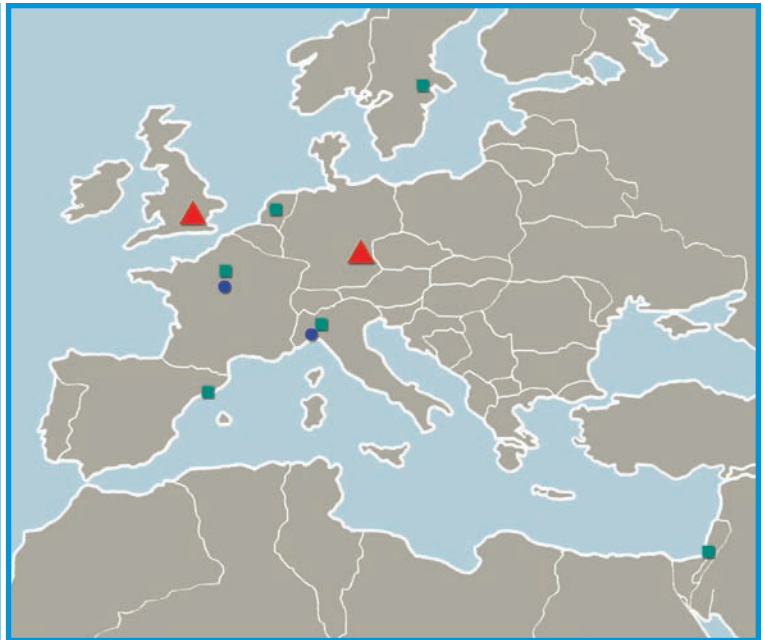
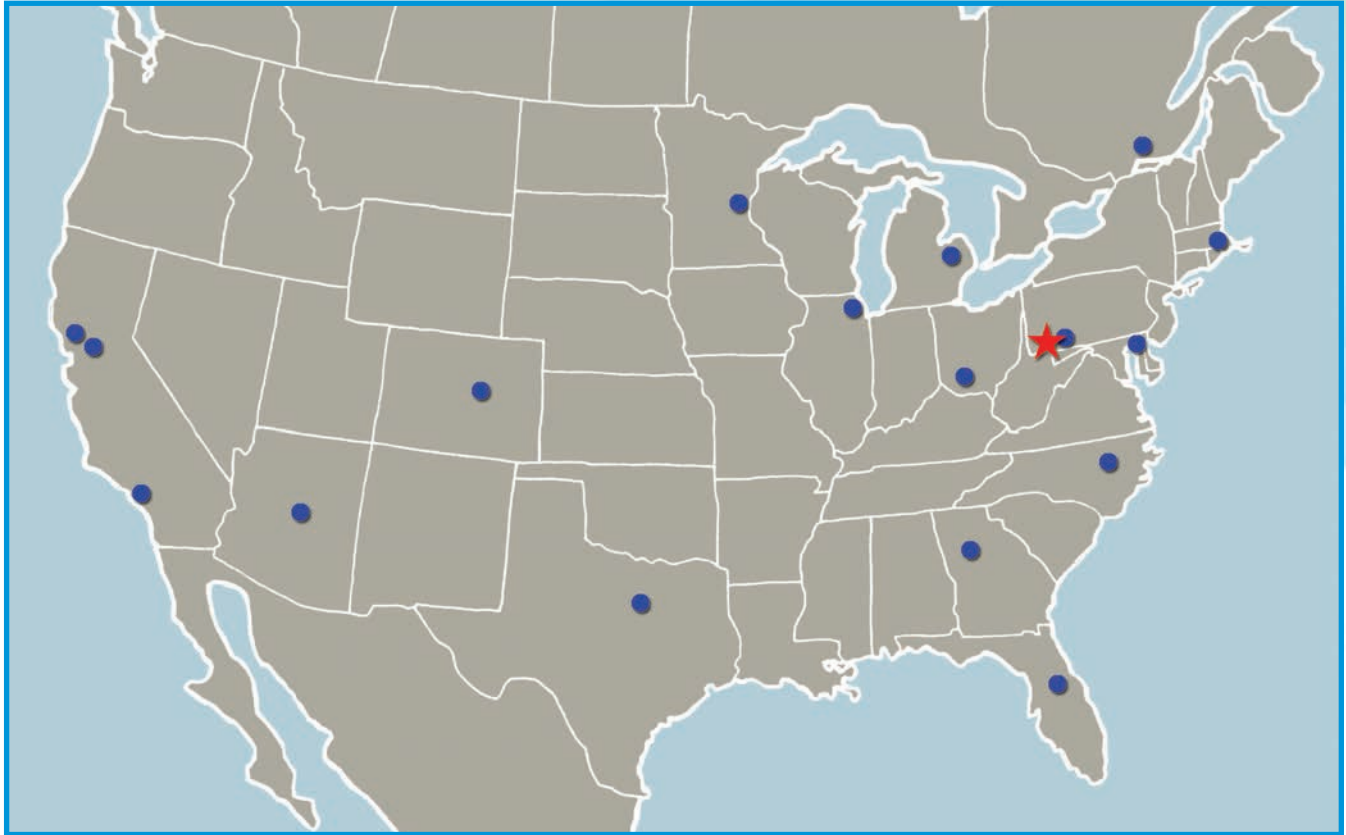

★ - Aerotech Headquarters   ● - Direct Field Sales Office   ▲ - Aerotech Subsidiary   ■ - Representative